

Belt Conveyor Systems

Product & Installation Manual

24-in, 36-in, and 48-in Widths

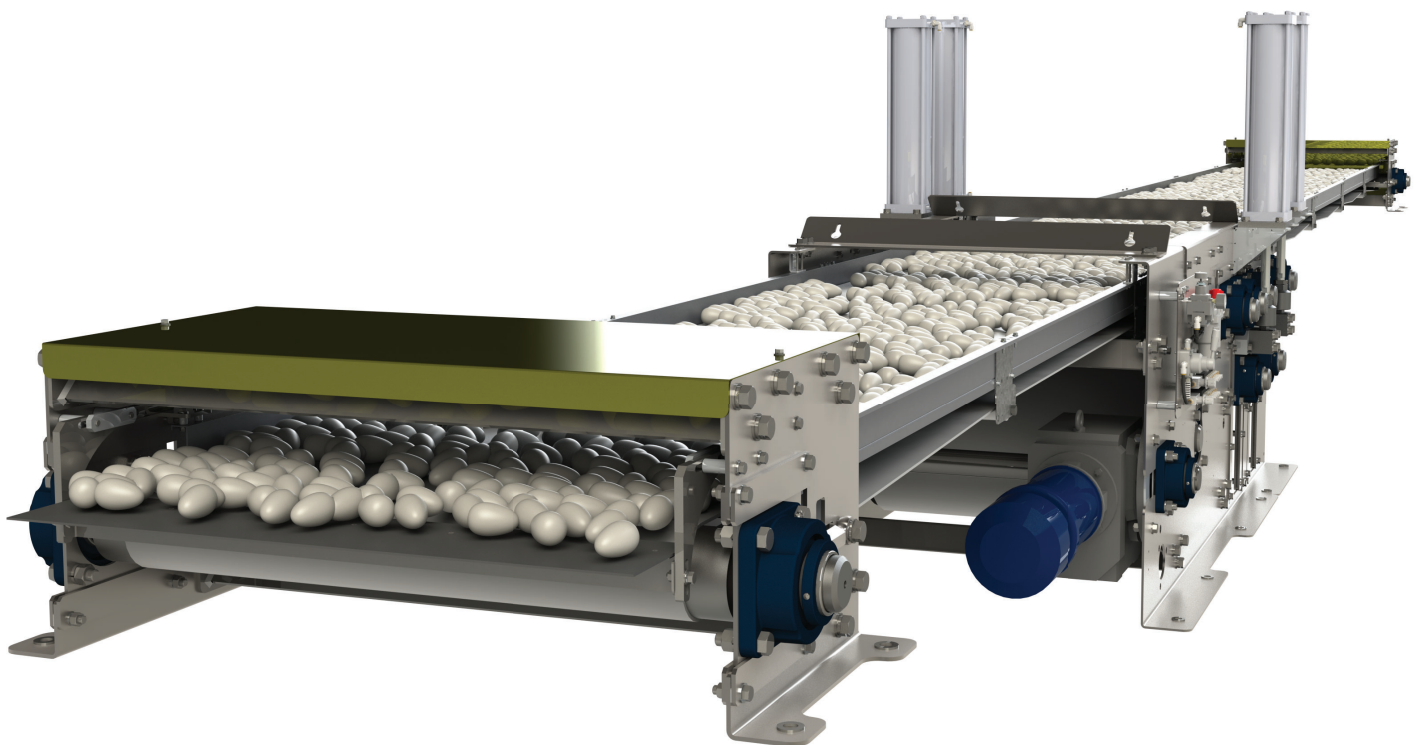

Table of Contents

SECTION 1 OVERVIEW	1-1
System Length	1-1
Component Dimensions	1-2
Drive Unit Dimensions	1-2
End Unit Dimensions	1-3
Modular Take-up Unit & Connecting Part Dimensions	1-4
Calculating Floor Support Heights	1-5
Recommended Clearances	1-6
SECTION 2 COMPONENT DETAILS	2-1
Drive Unit	2-1
Drive Roller Bearing Assembly	2-5
Drive Train Assembly	2-6
Fixed Bearing Assembly	2-7
Drive Shaft Bearing Assembly	2-8
Drive Unit Take-up Bearing Assembly	2-9
Drive Unit Tracking Bearing Assembly	2-10
Drive Slot Cover Plate Assembly	2-11
Chain Guard Assembly	2-12
Turnbuckle Assembly	2-13
Pneumatic Assembly	2-14
Tensioner Assembly	2-16
Cylinder Assembly	2-17
Belt Scraper Assembly	2-18
Support Weldment Assembly	2-19
End Unit, Front	2-20
Drive Unit Tracking Bearing Assembly	2-23
Turnbuckle Assembly	2-24
Support Weldment Assembly	2-25
Transfer Plate Assembly	2-26
End Unit Guard Mount Assembly	2-27
End Unit, Back	2-28
Drive Unit Tracking Bearing Assembly	2-31
Turnbuckle Assembly	2-32
Support Weldment Assembly	2-33
Belt Scraper Assembly	2-34
End Unit Guard Mount Assembly	2-35
Connecting Part	2-36
Adjustable Feet Kit (Optional)	2-38
Modular Take-Up Unit (Optional)	2-39
Fixed Bearing Assembly	2-42
Drive Unit Take-up Bearing Assembly	2-43
Cylinder Assembly	2-44
Support Weldment Assembly	2-45
Extruded Diverter Assembly with 60-in Diverter	2-46

Table of Contents

SECTION 3 ASSEMBLY & INSTALLATION	3-1
Preparing for Installation	3-1
Installation	3-5
Pneumatic Setup	3-17
Belt Threading	3-20
Belt Threading Modular Take-Up (Optional)	3-21
Belt Installation	3-22
Belt Cutting	3-27
Belt Splicing	3-30
Transfer Plate Adjustment	3-31
Belt Scraper Adjustment, Drive Unit	3-32
Belt Scraper Adjustment, End Unit	3-33
SECTION 4 START-UP & TROUBLESHOOTING	4-1
System Start-Up	4-1
Belt Tracking	4-2
Belt Speeds	4-4
System Break-In	4-4
Break-In Inspection Schedule	4-4
Troubleshooting	4-5
SECTION 5 MAINTENANCE	5-1
Preventive Maintenance	5-1
Inspection Schedule	5-2
Critical Spares All Widths	5-4
Critical Spares 24-in	5-4
Critical Spares 36-in	5-5
Critical Spares 48-in	5-5
Belt Cleaning	5-6
Pressure Settings	5-7
SECTION 6 GENERAL INFORMATION	6-1
OEM Contact Information	6-1
Lubing Contact Information	6-2

SECTION 1 OVERVIEW

System Length

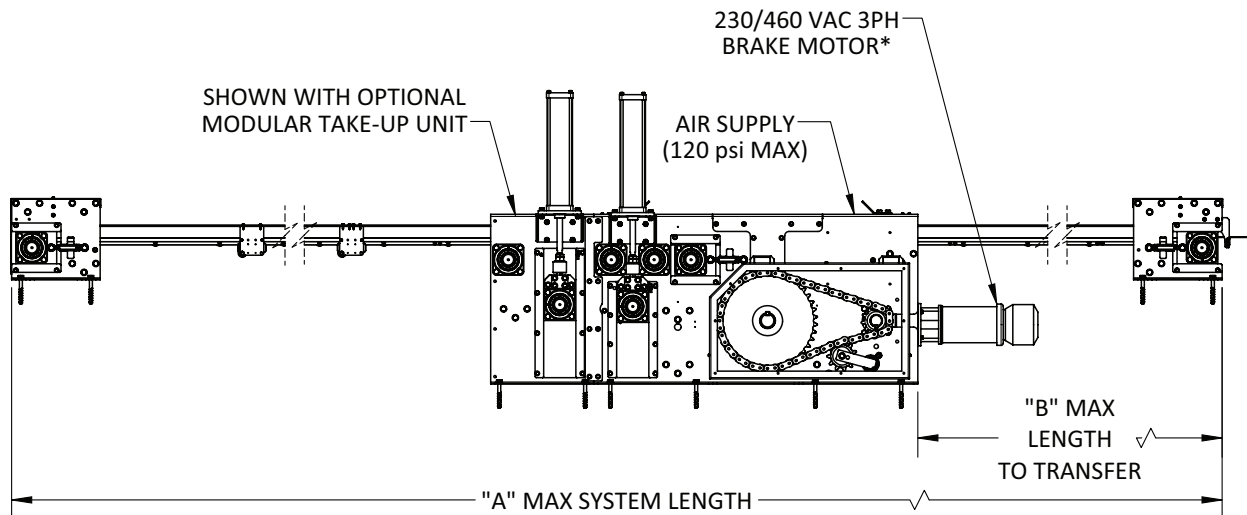
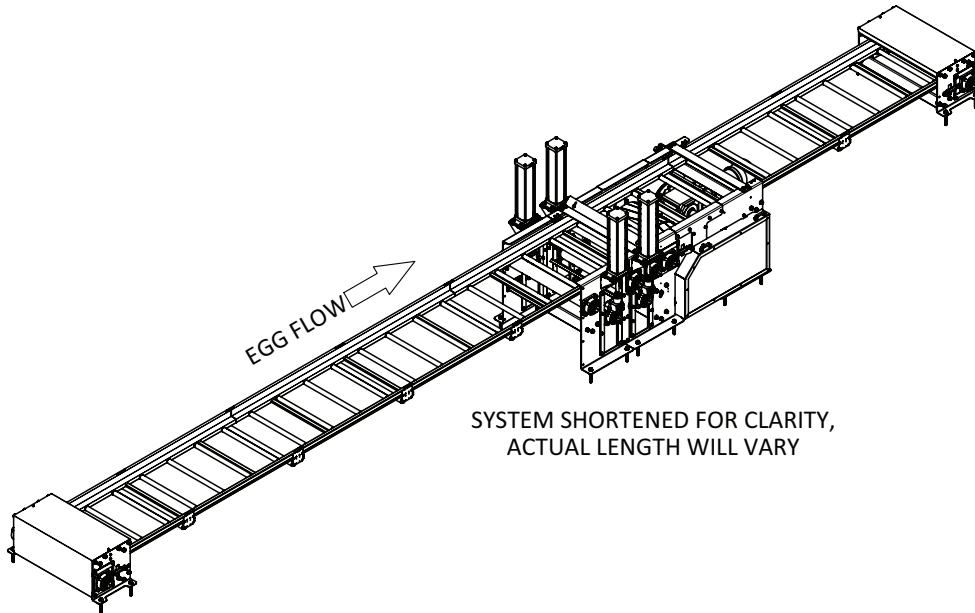

*REFER TO MANUFACTURER'S SPECIFICATIONS WHEN
WIRING VARIABLE FREQUENCY DRIVE (VFD)

System Lengths and Capacities			
Belt Width	A (ft/meters)	B (ft/meters)	Capacity (cases/hr)
24	1,500/457	750/228	300
36			450
48			600

Component Dimensions

Drive Unit Dimensions

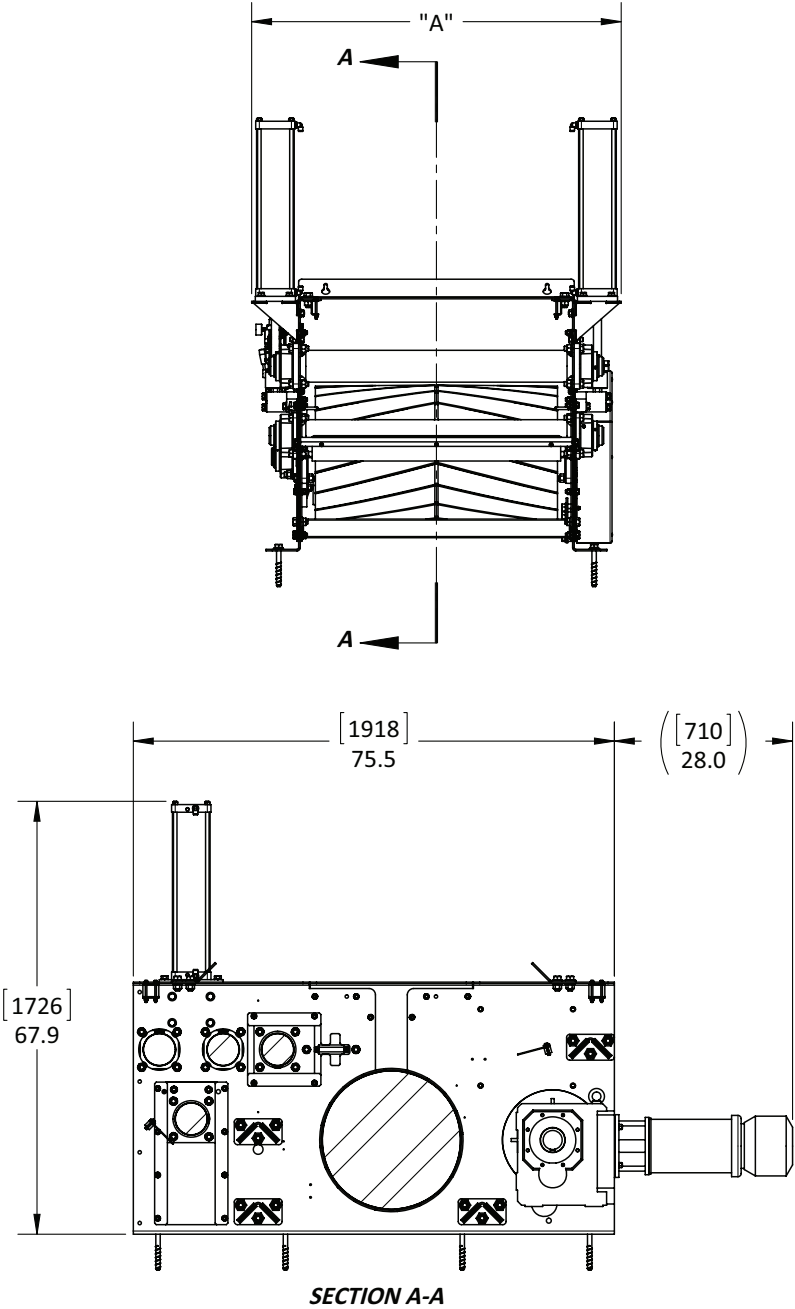

Drive Unit Dimensions			
Belt Width	Part/Drawing Number	Description	A (inches/mm)
24	700 001 01 01	Drive Unit, 24-in	46/1168
36	702 001 01 01	Drive Unit, 36-in	58/1473
48	704 001 01 01	Drive Unit, 48-in	70/1778

Overview

End Unit Dimensions

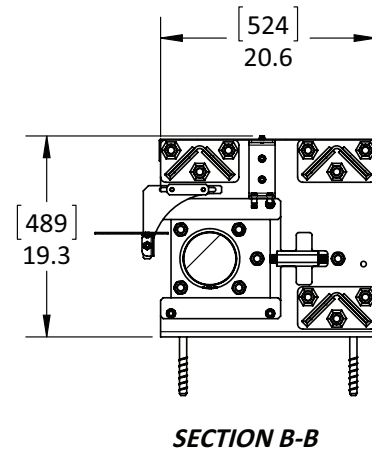
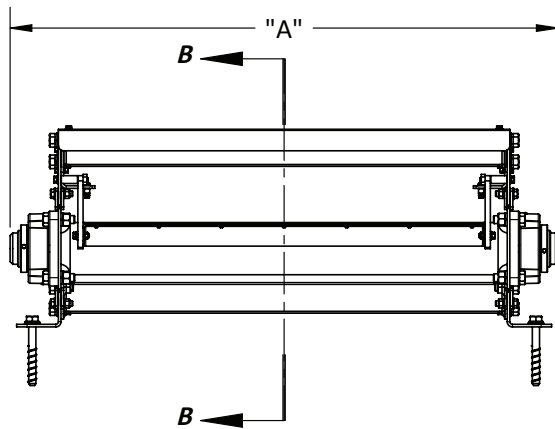

End Unit, Front Dimensions			
Belt Width	Part/Drawing Number	Description	A (inches/mm)
24	700 003 01 01	End Unit, Front, 24-in	40.5/1029
36	702 003 01 01	End Unit, Front, 36-in	52.5/1333
48	704 003 01 01	End Unit, Front, 48-in	64.5/1638

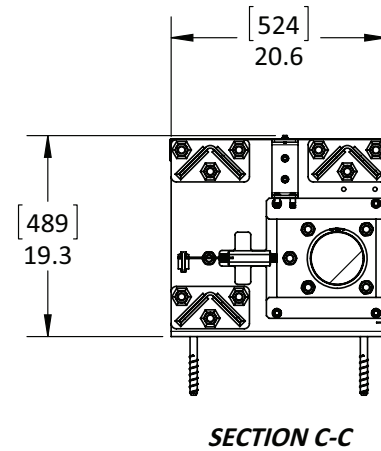
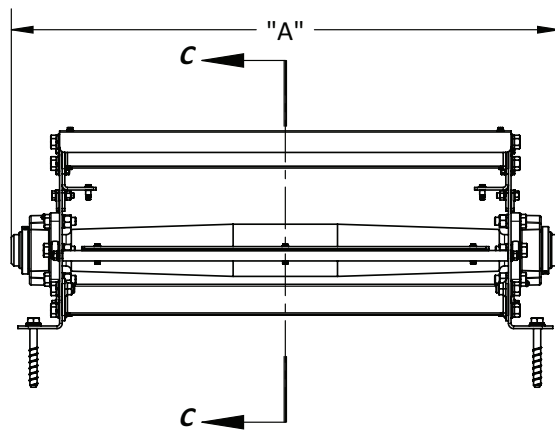

End Unit, Back Dimensions			
Belt Width	Part/Drawing Number	Description	A (inches/mm)
24	700 002 01 01	End Unit, Back, 24-in	40.5/1029
36	702 002 01 01	End Unit, Back, 36-in	52.5/1333
48	704 002 01 01	End Unit, Back, 48-in	64.5/1638

Modular Take-up Unit & Connecting Part Dimensions

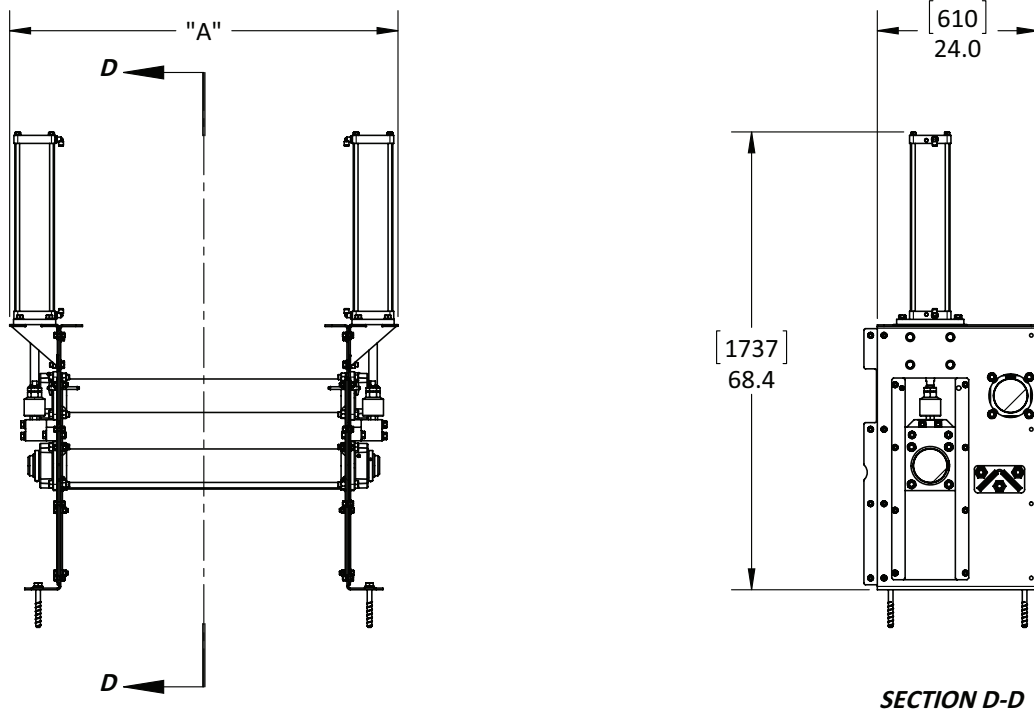

Modular Take-up Unit Dimensions			
Belt Width	Part/Drawing Number	Description	A (inches/mm)
24	700 006 01 01	Modular Take-up Unit, 24-in	46/1168
36	702 006 01 01	Modular Take-up Unit, 36-in	58/1473
48	704 006 01 01	Modular Take-up Unit, 48-in	70/1778

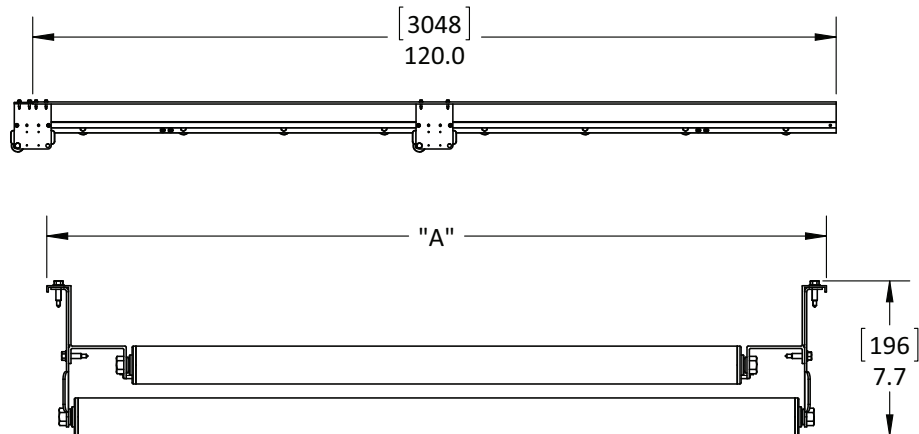

Connecting Part Dimensions			
Belt Width	Part/Drawing Number	Description	A (inches/mm)
24	700 005 05 00	Connecting Part, 24-in	26.8/681
36	702 005 05 05	Connecting Part, 36-in	38.8/986
48	704 004 01 00	Connecting Part, 48-in	50.8/1290

Calculating Floor Support Heights

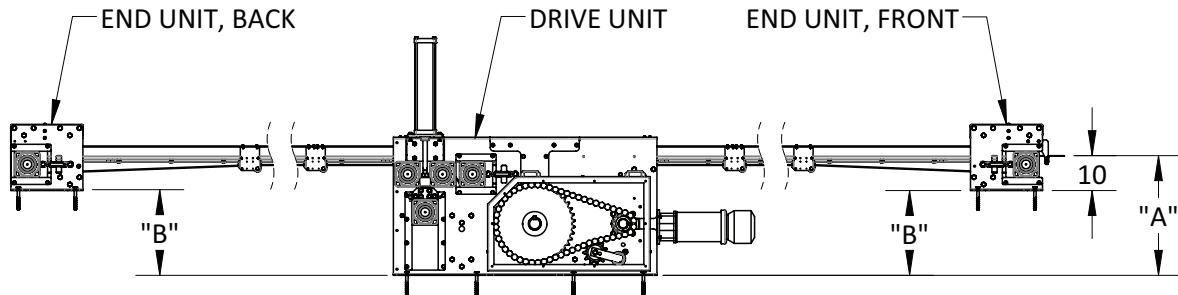

DETERMINE TRANSFER HEIGHT "A" AT THE END UNIT, FRONT

$A - 10" = \text{END UNIT SUPPORT STAND HEIGHT "B"}$

IF "B" IS HIGHER THAN 24", DRIVE UNIT FLOOR SUPPORTS WILL BE REQUIRED

$B - 24" = \text{DRIVE UNIT FLOOR SUPPORT HEIGHT}$

CALCULATIONS ASSUME LEVEL FLOOR AND CONSISTENT ELEVATION, IF FLOOR ELEVATION CHANGES AT THE LOCATION OF THE COMPONENTS ABOVE, ADDITIONAL HEIGHT MAY BE REQUIRED

FLOOR SUPPORT/SUPPORT STAND CONSTRUCTION
MAY DIFFER BASED ON TOTAL HEIGHTS REQUIRED

Recommended Clearances

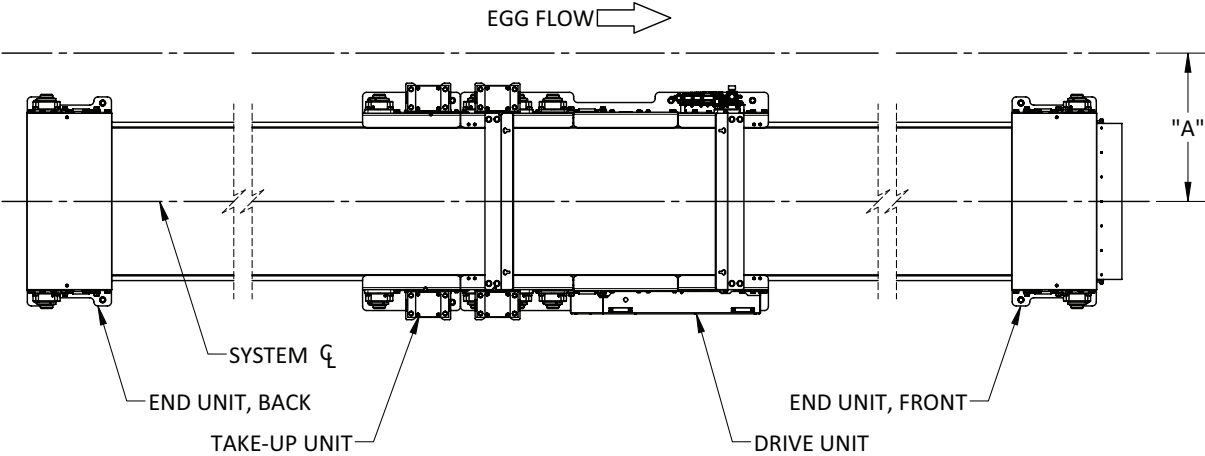

Recommended Clearances from System ζ		
Belt Width	Component	A (inches/mm)
24	Drive Unit/Take-up Unit	78/1981
	End Units/Connecting Parts	30/762
36	Drive Unit/Take-up Unit	84/2134
	End Units/Connecting Parts	36/914
48	Drive Unit/Take-up Unit	90/2286
	End Units/Connecting Parts	42/1067

SECTION 2 COMPONENT DETAILS

Drive Unit

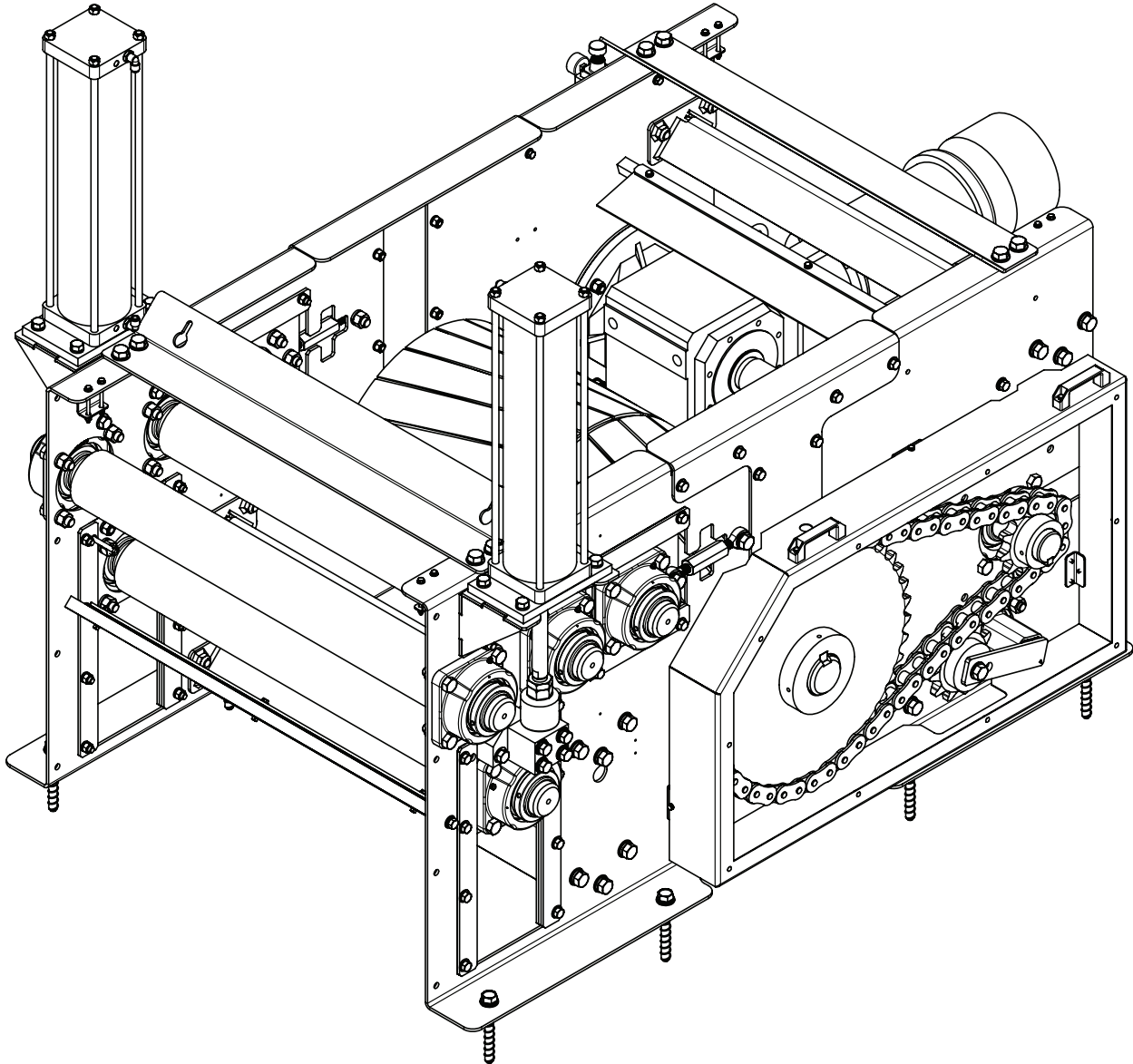

Drive Unit			
Belt Width	Part Number	Drawing Number	Description
24	--	700 001 01 01	Drive Unit, 24-in
36	--	702 001 01 01	Drive Unit, 36-in
48	--	704 001 01 01	Drive Unit, 48-in

Component Details

ITEM NO.	DRAWING NO.	PART NO.	DESCRIPTION	24-in	36-in	48-in
1	704 010 01 01		Drive Unit Side Sheet, LH	1	1	1
2	704 010 02 01		Drive Unit Side Sheet, RH	1	1	1
3	700 010 37 00		Tapered Roller, 24-in	1	-	-
3	702 010 37 00		Tapered Roller, 36-in	-	1	-
3	704 010 05 00		Tapered Roller, 48-in	-	-	1
4	700 010 36 00		Straight Roller, 24-in	3	-	-
4	702 010 36 00		Straight Roller, 36-in	-	3	-
4	704 010 06 00		Straight Roller, 48-in	-	-	3
5	700 010 13 00		Gearbox Axle, 24-in	1	-	-
5	702 010 13 00		Gearbox Axle, 36-in	-	1	-
5	704 010 13 00		Gearbox Axle, 48-in	-	-	1
6	704 010 14 00		Bearing Nut Plate	1	1	1
7	704 010 17 00		Drive Sprocket	1	1	1
8	704 010 18 00		Driven Sprocket	1	1	1
9	704 010 19 00		Keystock, Drive Sprocket	1	1	1
10	704 010 20 00		Keystock, Driven Sprocket	1	1	1
11	704 010 24 00		Gearbox Keystock	1	1	1
12	704 011 01 00		Sliding Bearing Holding Plate, Long	8	8	8
13	704 011 02 00		Sliding Bearing Holding Plate Shim, Long	4	4	4
14	704 011 03 00		Sliding Bearing Holding Plate, Short	8	8	8
15	704 011 04 00		Sliding Bearing Holding Plate Shim, Short	4	4	4
16	704 011 07 00	See Chart	3/8' Quick Pin 3-in Length	2	2	2
17	700 510 16 00		Drive Roller, 24-in	1	-	-
17	702 510 16 00		Drive Roller, 36-in	-	1	-
17	704 220 02 00		Drive Roller, 48-in	-	-	1
18	704 510 01 01		Drive Roller Bearing Assembly	2	2	2
19	704 510 02 01		Drive Train Assembly	1	1	1
20	704 510 04 01		Fixed Bearing Assembly	4	4	4
21	704 510 04 02		Drive Shaft Bearing Assembly	2	2	2
22	704 510 04 03		Drive Unit Take-up Bearing Assembly	2	2	2
23	704 510 04 04		Drive Unit Tracking Bearing Assembly	2	2	2
24	700 510 05 00		Support Weldment Assembly, 24-in	4	-	-
24	702 510 05 00		Support Weldment Assembly, 36-in	-	4	-
24	704 510 05 00		Support Weldment Assembly, 48-in	-	-	4
25	704 510 06 01		Drive Slot Cover Plate Assembly	2	2	2
26	704 510 07 00		Chain Guard Assembly	1	1	1
27	704 510 11 00		Turnbuckle Assembly	2	2	2
28	704 510 12 01		Connecting Part Bracket	4	4	4
29	704 510 13 00		Pneumatic Assembly	1	1	1
30	700 510 14 00		Hoisting Support Angle, 24-in	2	-	-
30	702 510 14 00		Hoisting Support Angle, 36-in	-	2	-
30	704 510 14 00		Hoisting Support Angle, 48-in	-	-	2
31	704 510 15 00		Tensioner Assembly	1	1	1
32	704 511 03 01		Cylinder Assembly	2	2	2
33	700 514 01 00		Belt Scraper Assembly, 24-in	2	-	-
33	702 514 01 00		Belt Scraper Assembly, 36-in	-	2	-
33	704 514 01 00		Belt Scraper Assembly, 48-in	-	-	2
34		RS140	#140 Roller Chain, Steel	1	1	1
35		F8-7-19-2-52	1/4-20 x 3-1/4" Hex Bolt, Stainless	8	8	8
36		F8-7-23-2-24	1/2-13 x 1-3/4" Hex Bolt, Stainless	24	24	24
37		F8-22-19-2-0	1/4-20 Hex Nut, Stainless	8	8	8
38		F8-22-23-0-0	1/2-13 Hex Nut, Stainless	24	24	24
39		F8-92-19-0-0	1/4" Flat Washer, Stainless	8	8	8
40		F8-92-23-0-0	1/2" Flat Washer, Stainless	24	24	24
41		F8-92-27-0-0	3/4" Flat Washer, Stainless	24	24	24
42		F8-96-19-0-0	1/4" Lock Washer, Stainless	8	8	8
43		F8-96-23-0-0	1/2" Lock Washer, Stainless	24	24	24
44		F9-7-27-2-28	3/4-10 x 1-3/4" Grade 8 Hex Bolt, Zinc	8	8	8
45		F9-22-27-0-0	3/4-10 Grade 8 Hex Nut, Zinc	8	8	8
46		F9-77-27-0-96	3/4" x 6" Masonary Hex Head Screw, Zinc	8	8	8

Component Details

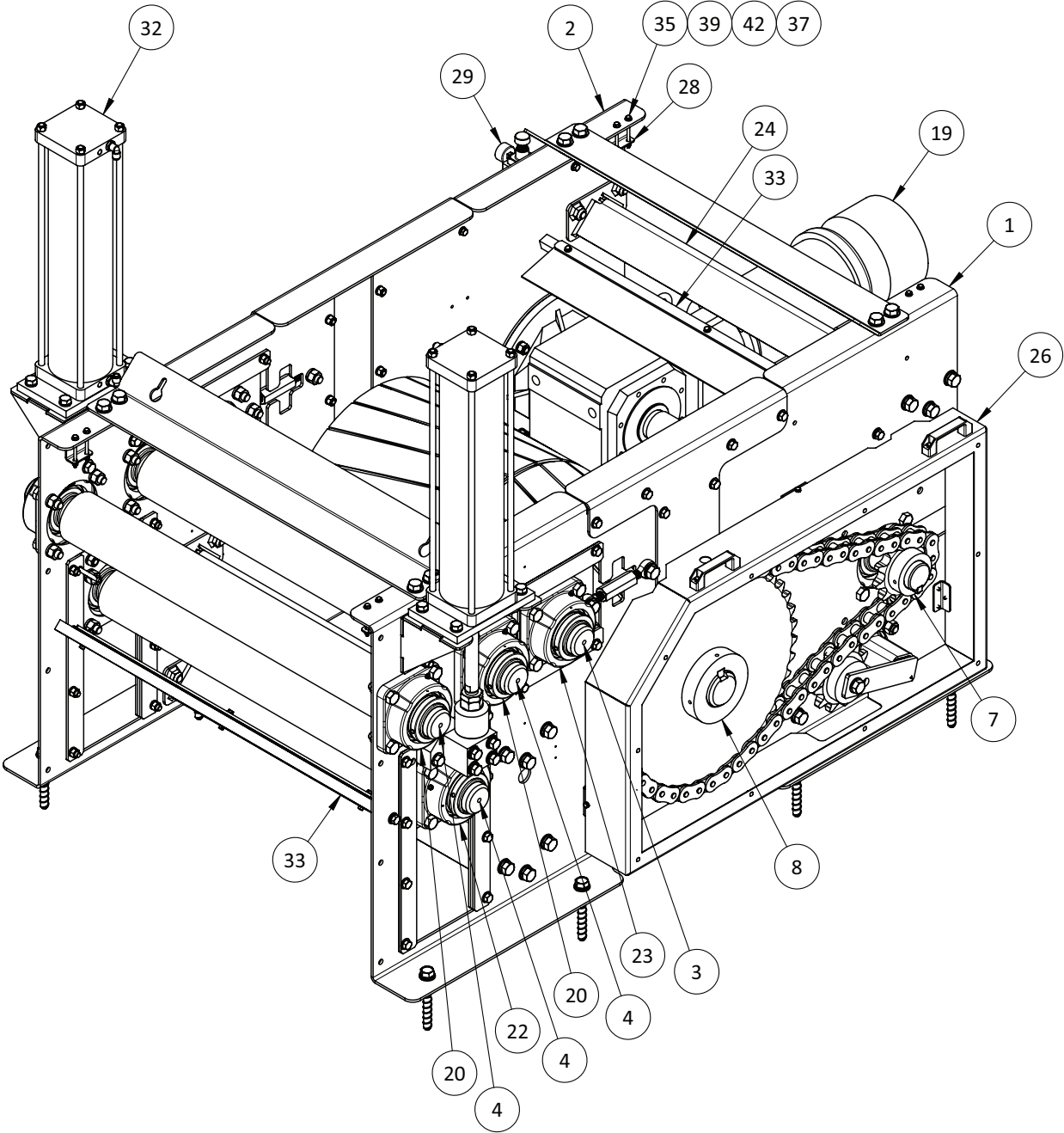

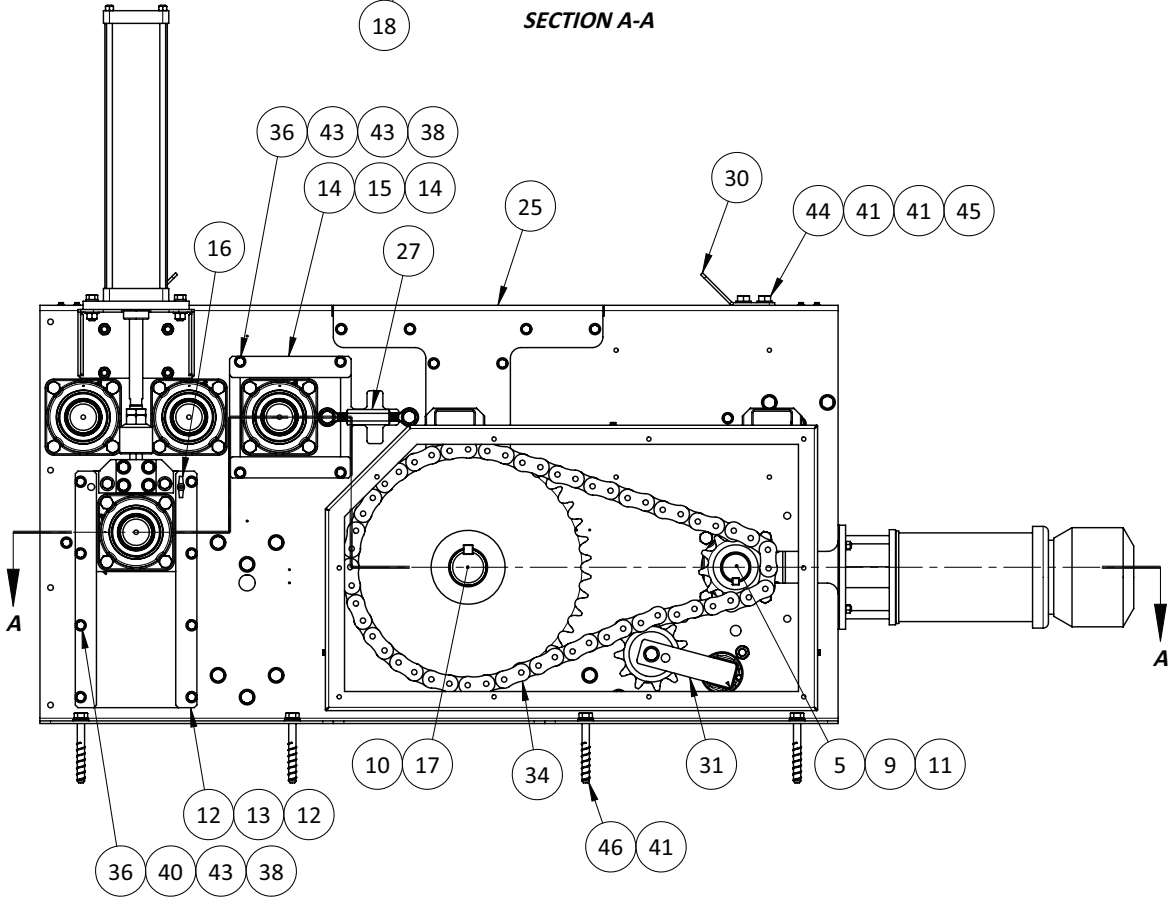
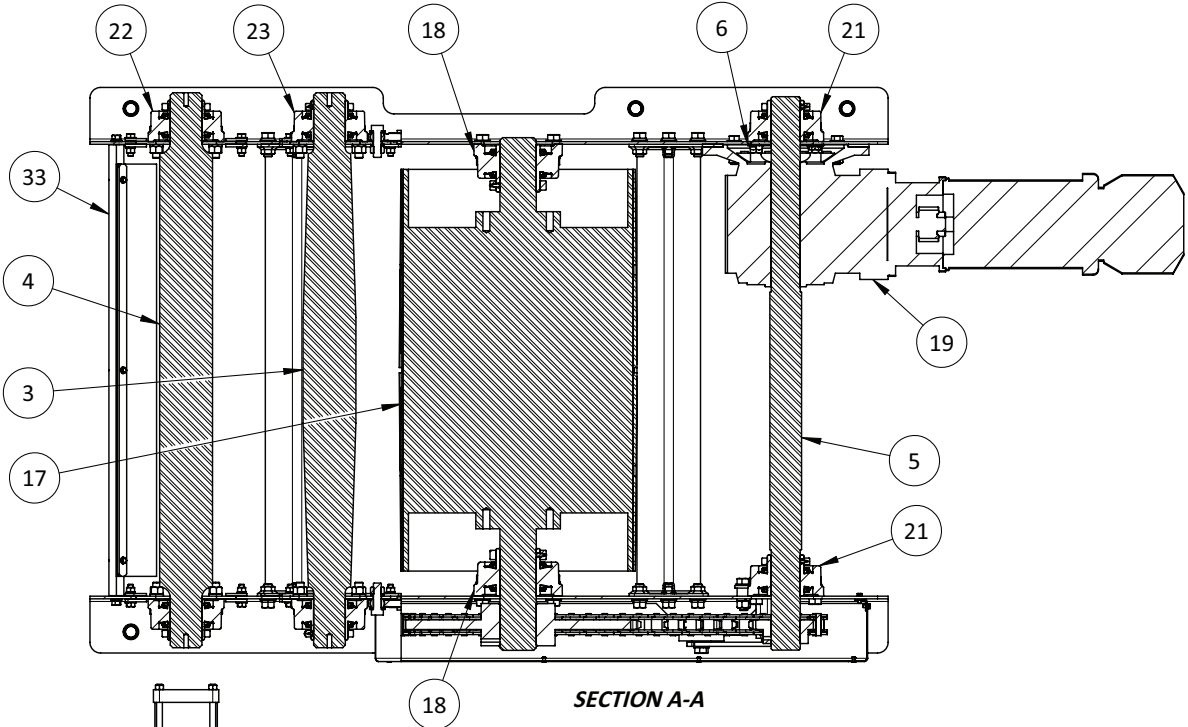

Component Details

Drive Roller Bearing Assembly

ITEM NO.	DRAWING NO.	PART NO.	DESCRIPTION	QTY.
1	704 010 27 00	See Chart	4-Bolt Flange Bearing, 3-7/16-in	1
2		F8-7-27-2-40	3/4-10 x 2-1/2" Hex Bolt, Stainless	4
3		F8-22-27-0-0	3/4-10 Hex Nut, Stainless	4
4		F8-92-27-0-0	3/4" Flat Washer, Stainless	4
5		F8-96-27-0-0	3/4" Lock Washer, Stainless	4

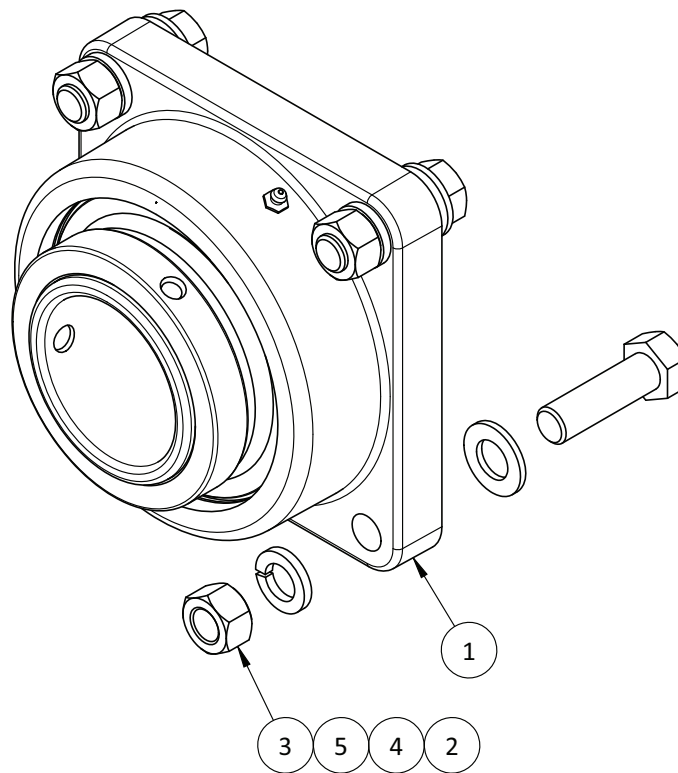

Drive Roller Bearing Assembly			
Belt Width	Part Number	Drawing Number	Description
24	--	704 510 01 01	Drive Roller Bearing Assembly
36			
48			

Drive Train Assembly

ITEM NO.	DRAWING NO.	PART NO.	DESCRIPTION	QTY.
1	704 010 12 00		Gearbox Spacer Ring	1
2		K814AF1250MR250 EL2	Gearbox, 125:1	1
3		131612	7.5 HP 3-Phase AC Motor	1
4		F8-7-25-2-36	5/8-11 x 2-1/4" Hex Bolt, Stainless	4
5		F8-22-25-0-0	5/8-11 Hex Nut, Stainless	4
6		F8-92-25-0-0	5/8" Flat Washer, Stainless	4
7		F8-96-25-0-0	5/8" Lock Washer, Stainless	4

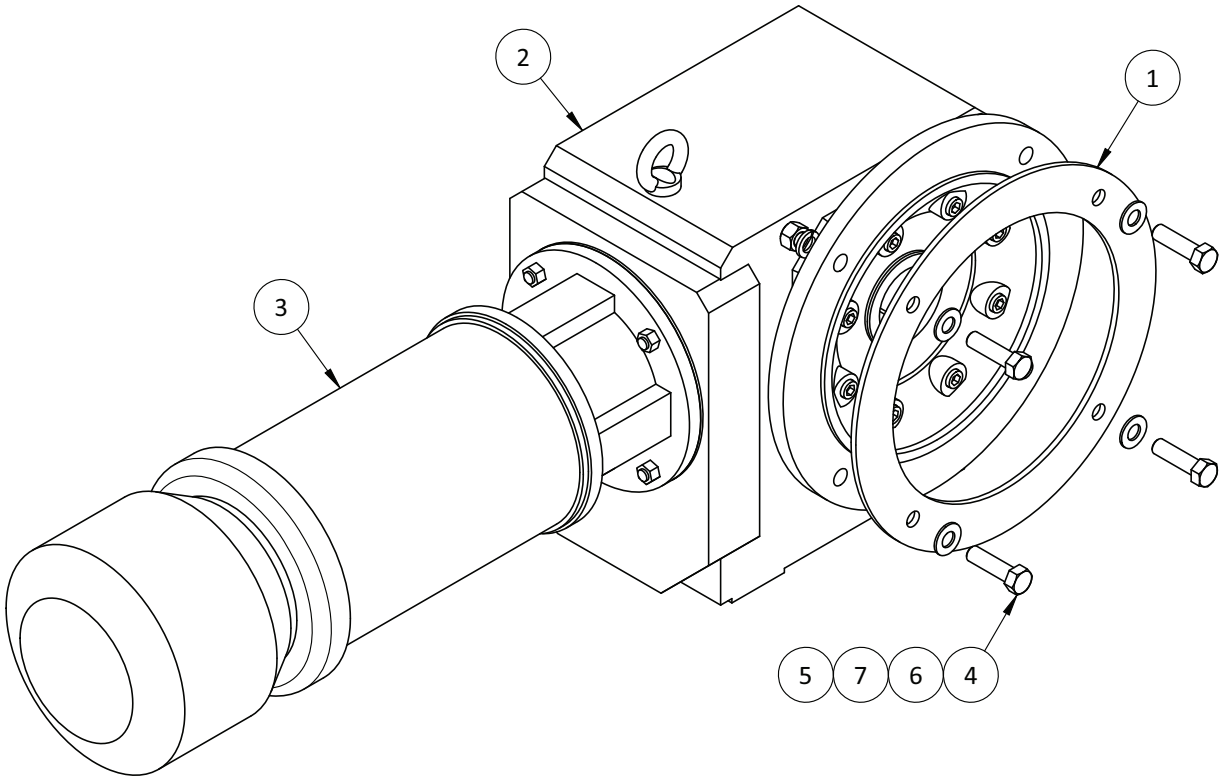

Drive Train Assembly			
Belt Width	Part Number	Drawing Number	Description
24	--	704 510 02 01	Drive Train Assembly
36			
48			

Component Details

Fixed Bearing Assembly

ITEM NO.	DRAWING NO.	PART NO.	DESCRIPTION	QTY.
1	704 010 25 00	SEE CHART	4-Bolt Flange Bearing, 3-in	1
2		F8-7-27-2-40	3/4-10 x 2-1/2" Hex Bolt, Stainless	4
3		F8-22-27-0-0	3/4-10 Hex Nut, Stainless	4
4		F8-96-27-0-0	3/4" Lock Washer, Stainless	4

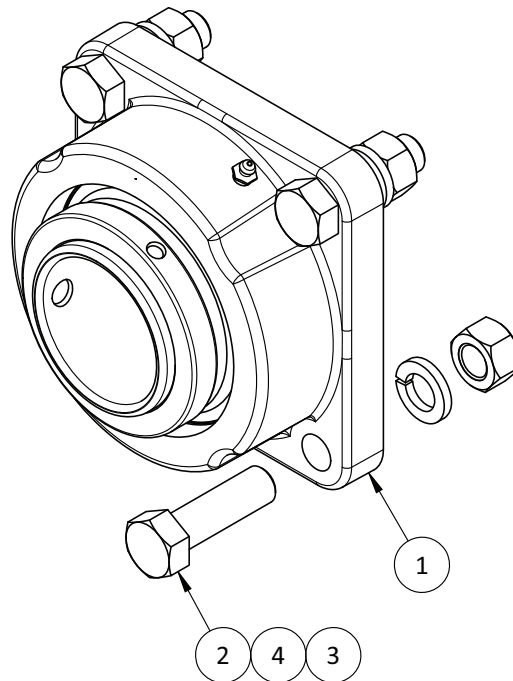

Fixed Bearing Assembly			
Belt Width	Part Number	Drawing Number	Description
24	--	704 510 04 01	Fixed Bearing Assembly
36			
48			

Drive Shaft Bearing Assembly

ITEM NO.	DRAWING NO.	PART NO.	DESCRIPTION	QTY.
1	704 010 26 00	See Chart	4-Bolt Flange Bearing, 2-3/4-in	1
2		F8-7-27-2-40	3/4-10 x 2-1/2" Hex Bolt, Stainless	4
3		F8-22-27-0-0	3/4-10 Hex Nut, Stainless	4
4		F8-96-27-0-0	3/4" Lock Washer, Stainless	4

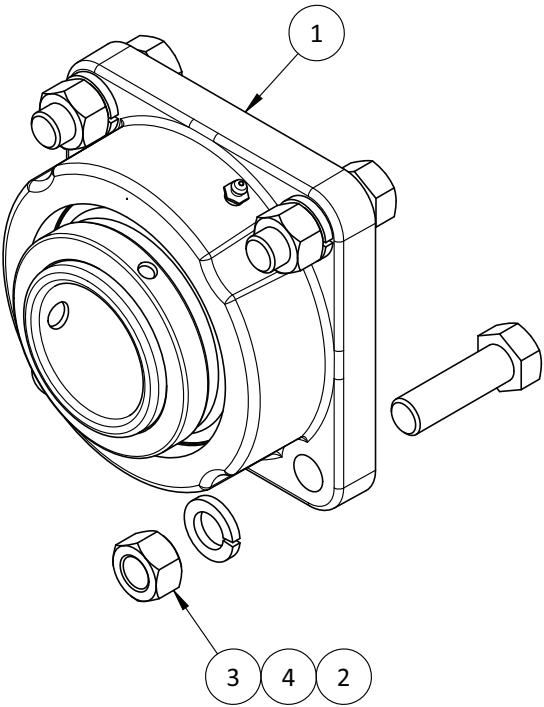

Drive Shaft Bearing Assembly			
Belt Width	Part Number	Drawing Number	Description
24	--	704 510 04 02	Drive Shaft Bearing Assembly
36			
48			

Component Details

Drive Unit Take-up Bearing Assembly

ITEM NO.	DRAWING NO.	PART NO.	DESCRIPTION	QTY.
1	704 010 04 00		Bearing Slide Plate, Take-up	1
2	704 010 25 00	SEE CHART	4-Bolt Flange Bearing, 3-in	1
3		F8-7-27-2-40	3/4-10 x 2-1/2" Hex Bolt, Stainless	4
4		F8-22-27-0-0	3/4-10 Hex Nut, Stainless	4
5		F8-96-27-0-0	3/4" Lock Washer, Stainless	4

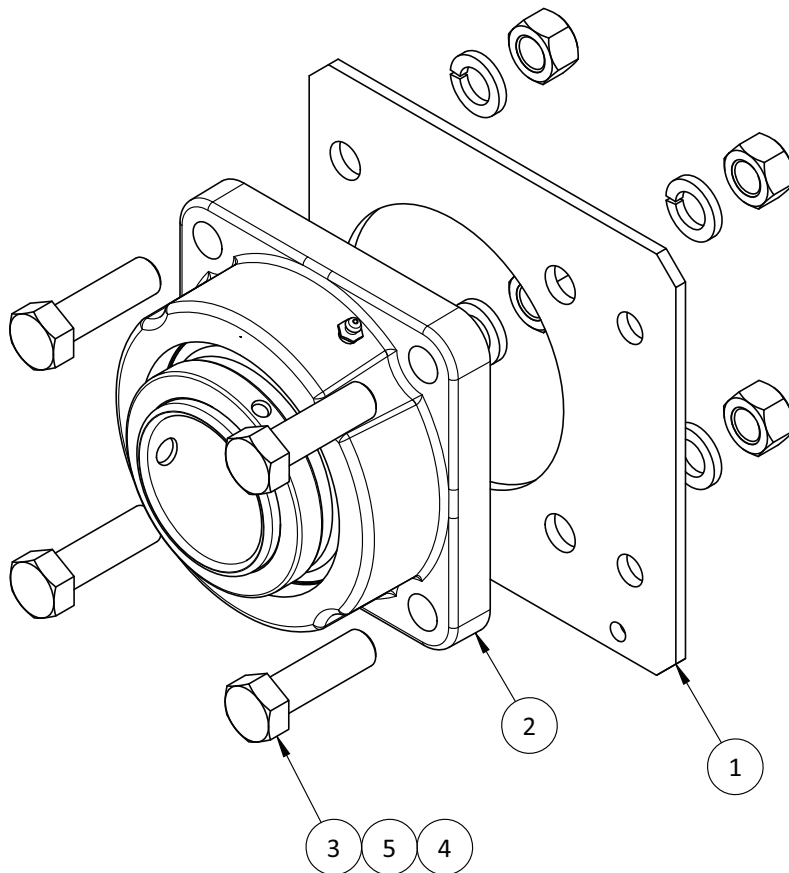

Drive Unit Take-up Bearing Assembly			
Belt Width	Part Number	Drawing Number	Description
24	--	704 510 04 03	Drive Unit Take-up Bearing Assembly
36			
48			

Drive Unit Tracking Bearing Assembly

ITEM NO.	DRAWING NO.	PART NO.	DESCRIPTION	QTY.
1	704 010 03 00		Bearing Slide Plate, Tracking	1
2	704 010 25 00	SEE CHART	4-Bolt Flange Bearing, 3-in	1
3		F8-7-27-2-40	3/4-10 x 2-1/2" Hex Bolt, Stainless	4
4		F8-22-27-0-0	3/4-10 Hex Nut, Stainless	4
5		F8-96-27-0-0	3/4" Lock Washer, Stainless	4

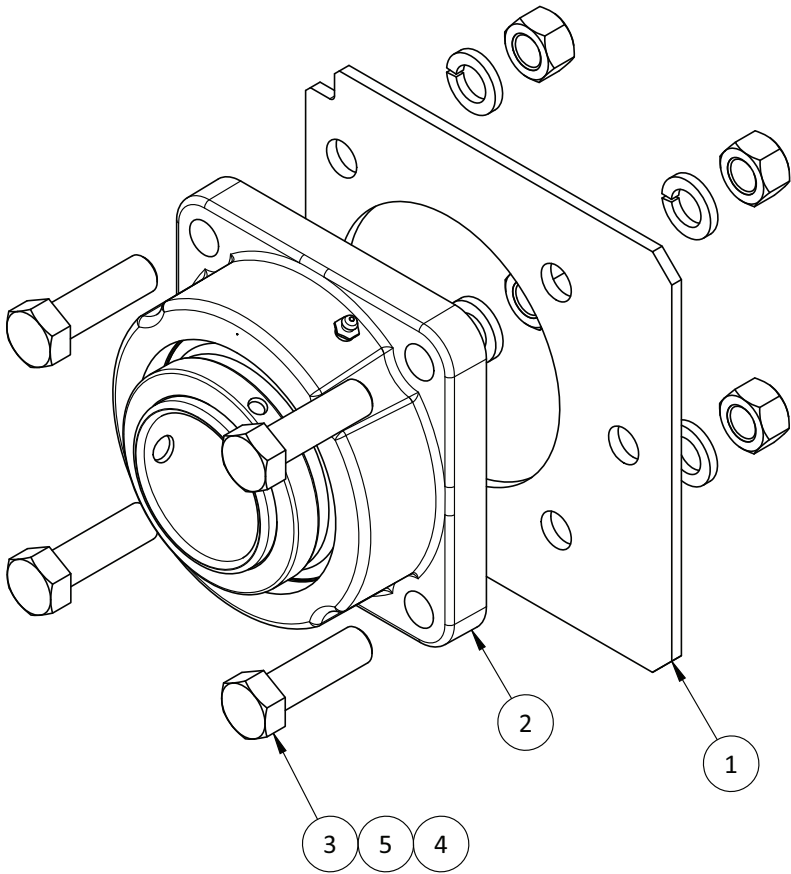

Drive Unit Tracking Bearing Assembly			
Belt Width	Part Number	Drawing Number	Description
24	--	704 510 04 04	Drive Unit Tracking Bearing Assembly
36			
48			

Component Details

Drive Slot Cover Plate Assembly

ITEM NO.	DRAWING NO.	PART NO.	DESCRIPTION	QTY.
1	704 010 08 01		Drive Roller Slot Cover Plate	1
2		F8-7-23-2-20	1/2-13 x 1-1/4" Hex Bolt, Stainless	8
3		F8-22-23-0-0	1/2-13 Hex Nut, Stainless	8
4		F8-92-23-0-0	1/2" Flat Washer, Stainless	8
5		F8-96-23-0-0	1/2" Lock Washer, Stainless	8

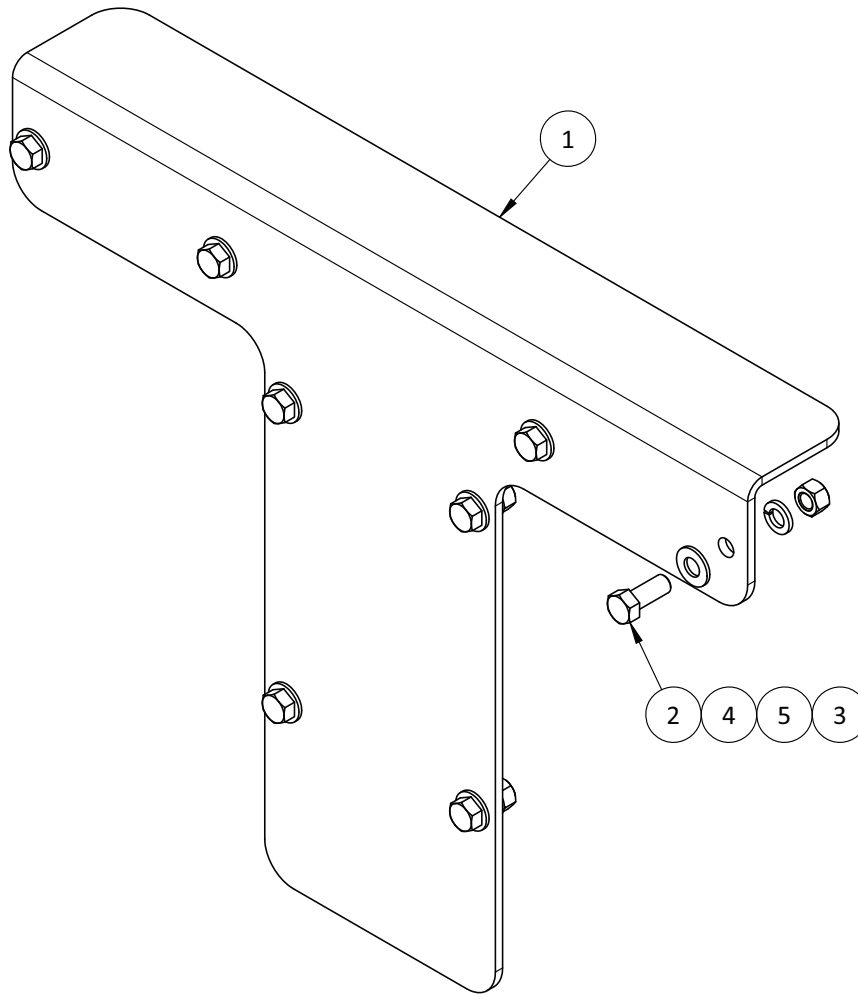

Drive Slot Cover Plate Assembly			
Belt Width	Part Number	Drawing Number	Description
24	--	704 510 06 01	Drive Slot Cover Plate Assembly
36			
48			

Chain Guard Assembly

ITEM NO.	DRAWING NO.	PART NO.	DESCRIPTION	QTY.
1	704 010 09 00		Sprocket and Chain Guard	1
2	704 010 10 00		Lexan Window	1
3	704 010 11 01		Guard Mounting Bracket	3
4		1078A321	Pull Handle, Black	2
5		F8-7-19-2-8	1/4-20 x 1/2" Hex Bolt, Stainless	3
6		F8-7-19-2-12	1/4-20 x 3/4" Hex Bolt, Stainless	6
7		F8-7-19-2-20	1/4-20 x 1-1/4" Hex Bolt, Stainless	4
8		F8-22-19-2-0	1/4-20 Hex Nut, Stainless	4
9		F8-40-19-0-6	1/4" x 3/8" Rivet, Stainless	10
10		F8-92-19-0-0	1/4" Flat Washer, Stainless	4
11		F8-96-19-0-0	1/4" Lock Washer, Stainless	9

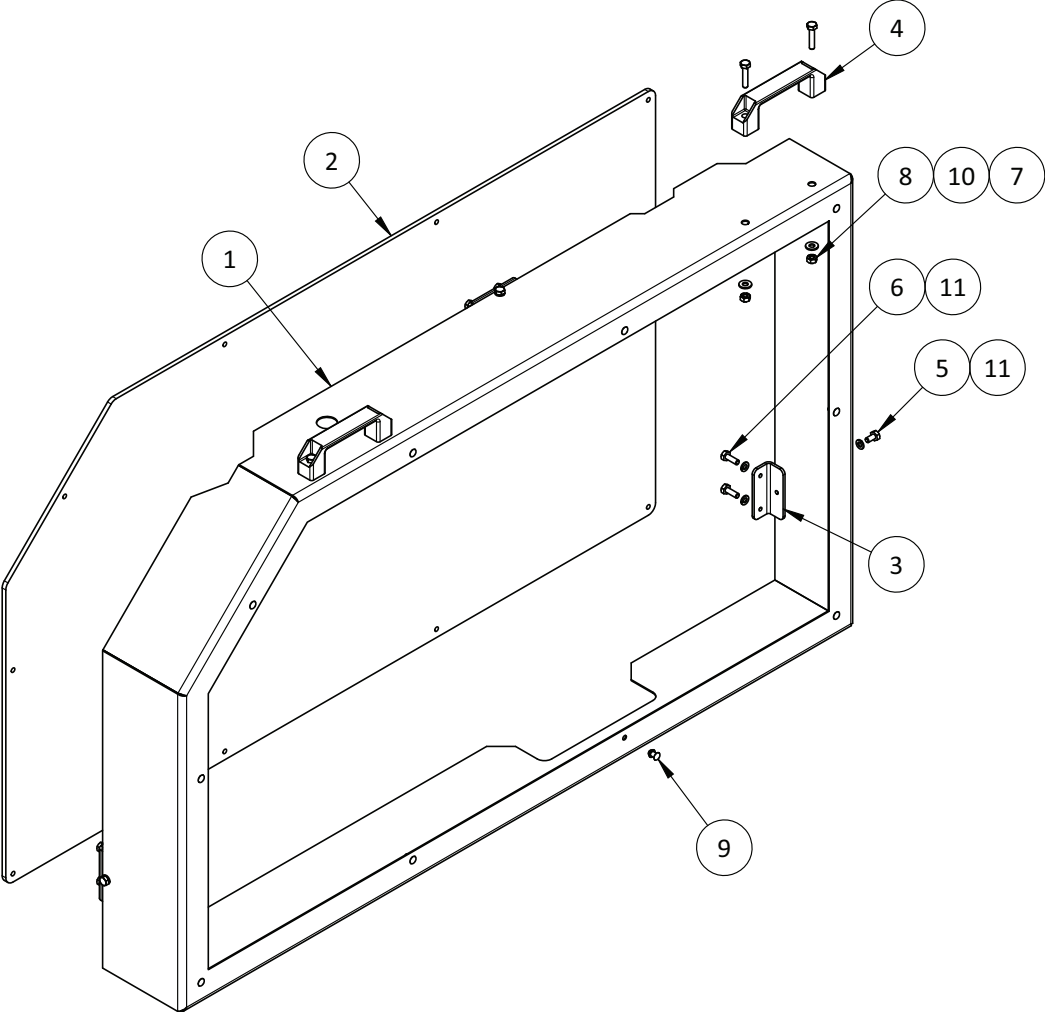

Chain Guard Assembly			
Belt Width	Part Number	Drawing Number	Description
24	--	704 510 07 00	Chain Guard Assembly
36			
48			

Component Details

Turnbuckle Assembly

ITEM NO.	DRAWING NO.	PART NO.	DESCRIPTION	QTY.
1	704 010 07 00		Turnbuckle Body	1
2		59915K278	RH Rod End	1
3		59915K282	LH Rod End	1
4		F8-7-27-2-40	3/4-10 x 2-1/2" Hex Bolt, Stainless	2
5		F8-22-27-0-0	3/4-10 Hex Nut, Stainless	2
6		F8-92-27-0-0	3/4" Flat Washer, Stainless	2
7		F8-96-27-0-0	3/4" Lock Washer, Stainless	2

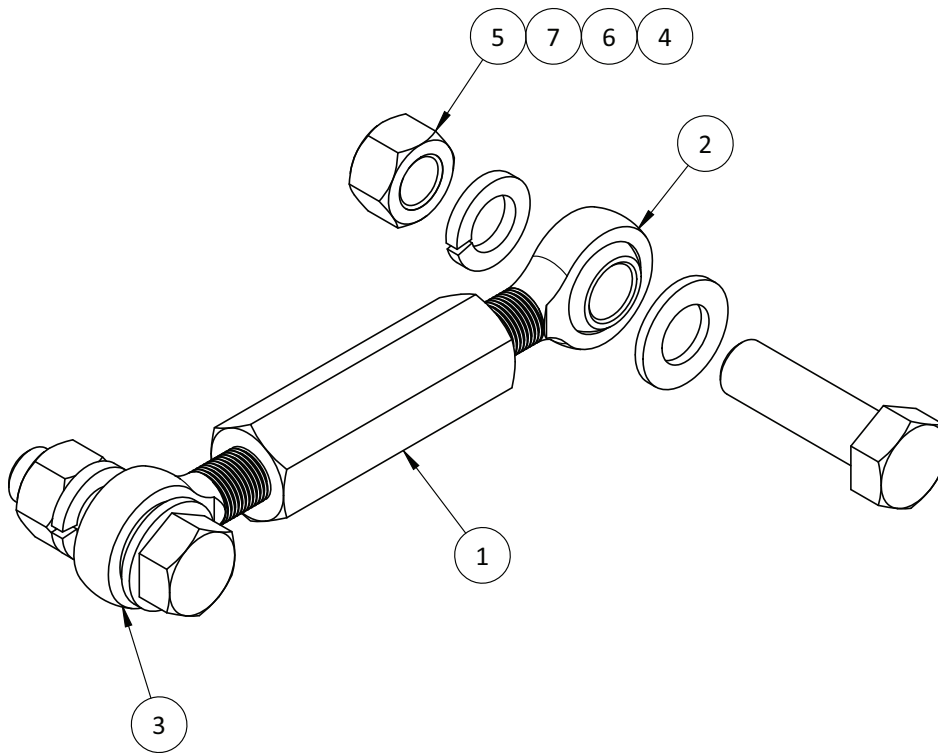

Turnbuckle Assembly			
Belt Width	Part Number	Drawing Number	Description
24	--	704 510 11 00	Turnbuckle Assembly
36			
48			

Pneumatic Assembly

ITEM NO.	DRAWING NO.	PART NO.	DESCRIPTION	QTY.
1	704 011 05 00		Pneumatic Plate Standoff	4
2	704 011 06 00		Pneumatic Panel	1
3		5469K155	Manifold 1/2" NPT Inlet, 6 x 3/8" NPT Outlets	2
4		5485K330	1/2" NPT x 3/8" NPT Reducer Nipple	2
5		44705K385	1/2-NPT Plug	2
6		AF30-N03-Z	Air Filter	1
7		AFM30-N03C-Z	Mist Separator	1
8		AMG250C-N03BD	Water Separator	1
9		AN303-03	Silencer	2
10		AS4000-N03	Mounted Flow Control	2
11		IR3020-N03BG	Precision Regulator	1
12		KQ2H11-36	Male Connector	14
13		KQ2L11-36S	3/8" NPT Tube Elbow Fitting	7
14		KQ2P-11	3/8" Plug	8
15		TIUB11B-20	Polyurethane Tubing, 3/8", 20m Roll	1
16		VH302-N03	Mechanical Hand Valve	1
17		VHS30-N03-Z	Manual Shutoff Valve	1
18		Y300	Spacer	1
19		Y300T	Mounting Bracket	3
20		F8-7-19-2-12	1/4-20 x 3/4" Hex Bolt, Stainless	6
21		F8-7-19-2-28	1/4-20 x 1-3/4" Hex Bolt, Stainless	4
22		F8-7-20-2-12	5/16-18 x 3/4" Hex Bolt, Stainless	2
23		F8-7-21-2-16	3/8-16 x 1" Hex Bolt, Stainless	8
24		F8-22-19-2-0	1/4-20 Hex Nut, Stainless	10
25		F8-22-20-0-0	5/16-18 Hex Nut, Stainless	2
26		F8-29-8-3-0	#10-32 Nylock Nut, Stainless	4
27		F8-73-8-2-32	#10-32 x 2" SHCS, Stainless	4
28		F8-92-8-0-0	#10 Flat Washer, Stainless	4
29		F8-92-19-0-0	1/4" Flat Washer, Stainless	10
30		F8-92-20-0-0	5/16" Flat Washer, Stainless	2
31		F8-92-21-0-0	3/8" Flat Washer, Stainless	8
32		F8-96-19-0-0	1/4" Lock Washer, Stainless	10
33		F8-96-20-0-0	5/16" Lock Washer, Stainless	2
34		F8-96-21-0-0	3/8" Lock Washer, Stainless	8

Pneumatic Assembly			
Belt Width	Part Number	Drawing Number	Description
24	--	704 510 13 00	Pneumatic Assembly
36			
48			

Component Details

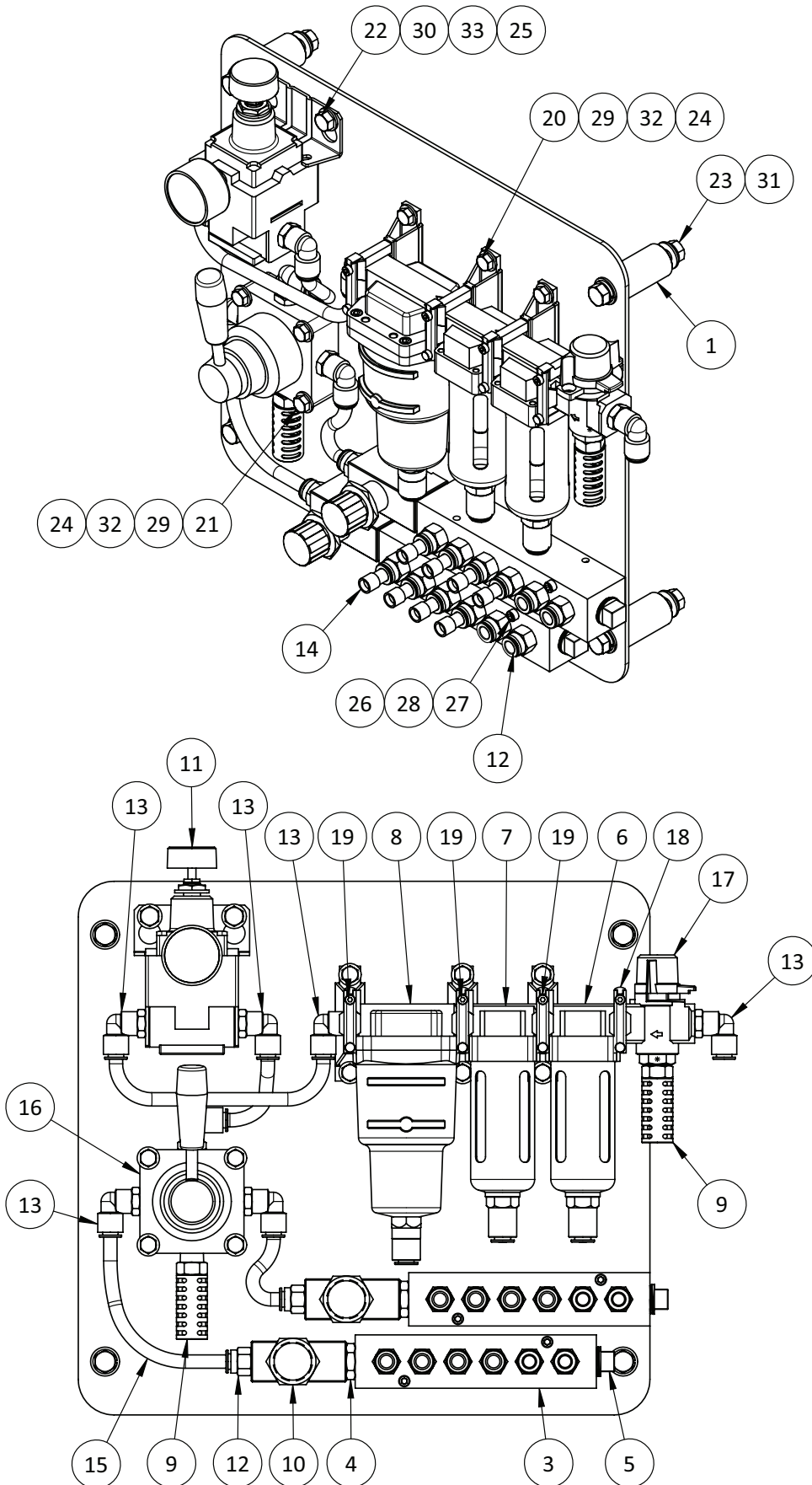

Tensioner Assembly

ITEM NO.	DRAWING NO.	PART NO.	DESCRIPTION	QTY.
1	704 010 21 00		Chain Tensioner Subplate	1
2	704 010 22 00		Chain Tensioner Standoff	3
3	704 010 23 00		Chain Tensioner Idler Shaft	1
4		6663K209	Idler Sprocket, #140, 11 Tooth	1
5		91590A139	Retaining Ring, 1-1/2"	1
6		SE 38 (06 011 005)	Chain Tensioner	1
7		F8-7-23-2-24	1/2-13 x 1-1/2" Hex Bolt, Stainless	1
8		F8-7-27-2-28	3/4-10 x 1-3/4" Hex Bolt, Stainless	1
9		F8-7-27-2-40	3/4-10 x 2-1/2" Hex Bolt, Stainless	3
10		F8-22-23-0-0	1/2-13 Hex Nut, Stainless	1
11		F8-22-27-0-0	3/4-10 Hex Nut, Stainless	3
12		F8-92-27-0-0	3/4" Flat Washer, Stainless	4
13		F8-96-27-0-0	3/4" Lock Washer, Stainless	3

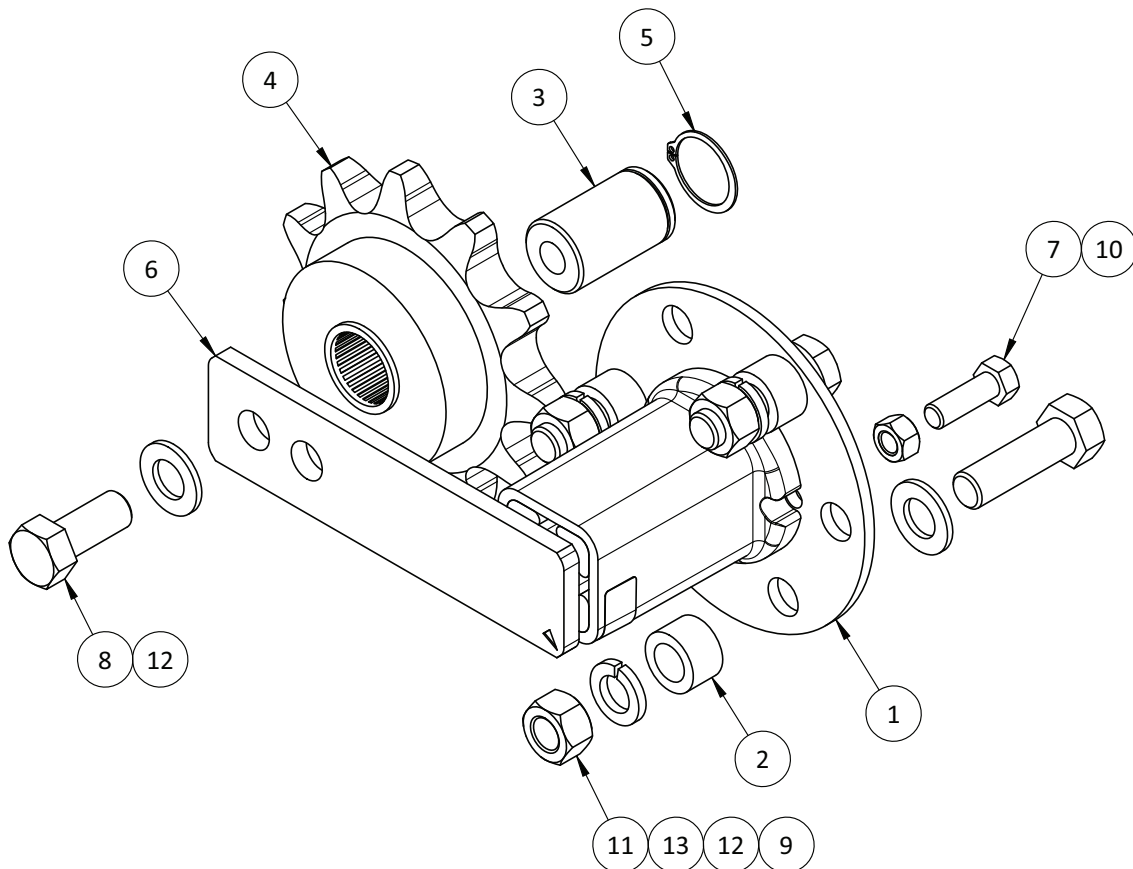

Tensioner Assembly			
Belt Width	Part Number	Drawing Number	Description
24	--	704 510 15 00	Tensioner Assembly
36			
48			

Component Details

Cylinder Assembly

ITEM NO.	DRAWING NO.	PART NO.	DESCRIPTION	QTY.
1	704 211 01 00		Floating Joint Connecting Bracket	1
2	704 211 02 01		Cylinder Mount Weldment	1
3		CS2F140TN-600	140mm Bore, 600mm Stroke Cylinder	1
4		JAHL80-30-150	Floating Joint	1
5		KQ2L11-37S	1/2" NPT Tube Elbow Fitting	2
6		F8-7-25-2-28	5/8-11 x 1-3/4" Hex Bolt, Stainless	4
7		F8-7-25-2-32	5/8-11 x 2" Hex Bolt, Stainless	4
8		F8-7-25-2-48	5/8-11 x 3" Hex Bolt, Stainless	2
9		F8-7-25-2-80	5/8-11 x 5" Hex Bolt, Stainless	4
10		F8-22-25-0-0	5/8-11 Hex Nut, Stainless	14
11		F8-92-25-0-0	5/8" Flat Washer, Stainless	14
12		F8-96-25-0-0	5/8" Lock Washer, Stainless	14
13		F9-23-70-3-0	M30 x 1.5 Jam Nut, Zinc	1

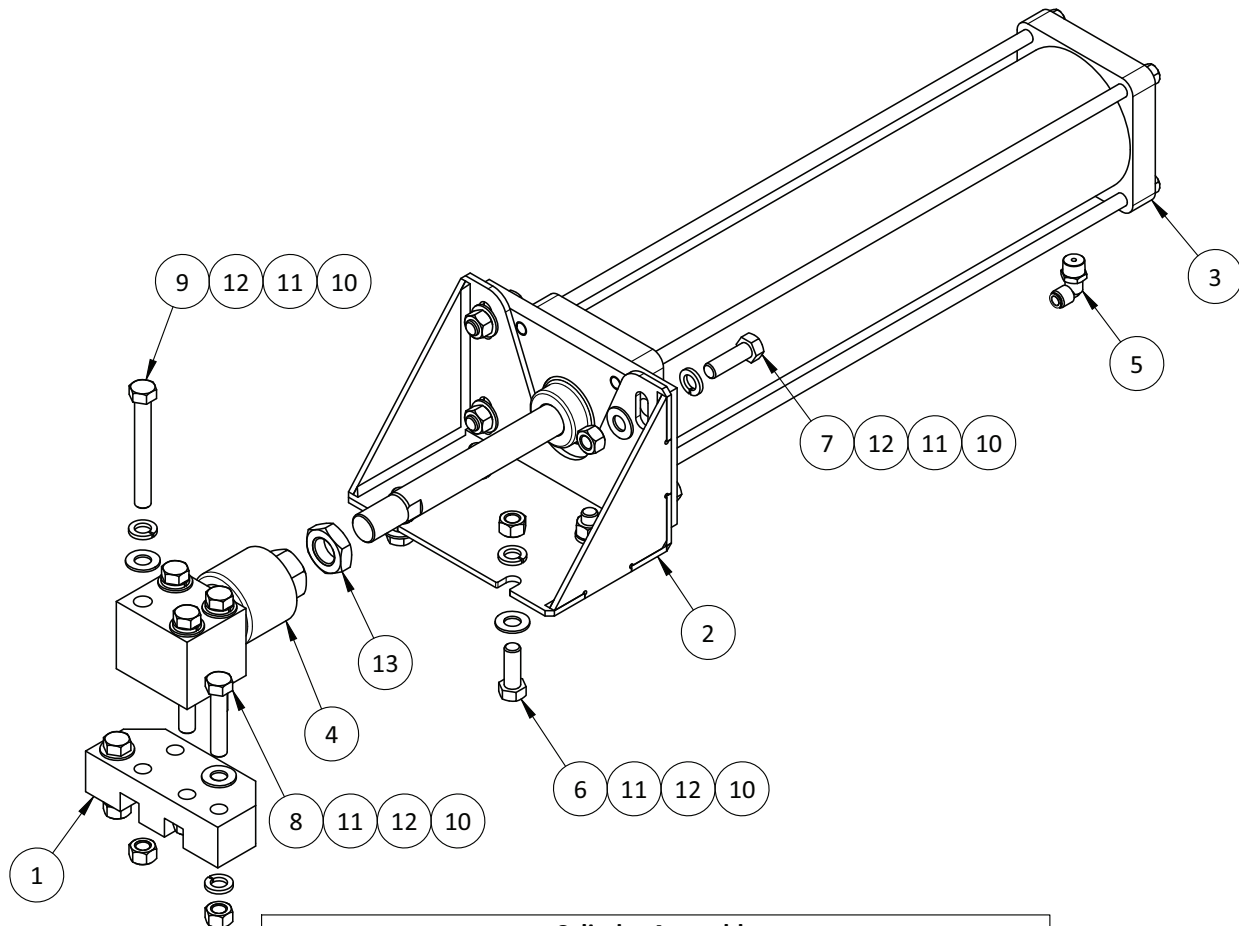

Cylinder Assembly			
Belt Width	Part Number	Drawing Number	Description
24	--	704 511 03 01	Cylinder Assembly
36			
48			

Belt Scraper Assembly

ITEM NO.	DRAWING NO.	PART NO.	DESCRIPTION	24-in	36-in	48-in
1	700 214 01 00		Belt Scraper Support Bar, 24-in	1	-	-
1	702 214 01 00		Belt Scraper Support Bar, 36-in	-	1	-
1	704 214 01 00		Belt Scraper Support Bar, 48-in	-	-	1
2	700 214 02 00		Belt Scraper Plate, 24-in	1	-	-
2	702 214 02 00		Belt Scraper Plate, 36-in	-	1	-
2	704 214 02 00		Belt Scraper Plate, 48-in	-	-	1
3	700 214 03 00		Belt Scraper Holding Plate, 24-in	1	-	-
3	702 214 03 00		Belt Scraper Holding Plate, 36-in	-	1	-
3	704 214 03 00		Belt Scraper Holding Plate, 48-in	-	-	1
4		F8-92-23-0-0	1/2" Flat Washer, Stainless	2	2	2
5		F8-96-23-0-0	1/2" Lock Washer, Stainless	2	2	2
6		F8-7-23-2-24	1/2-13 x 1-1/2" Hex Bolt, Stainless	2	2	2
7		F8-92-19-0-0	1/4" Flat Washer, Stainless	3	3	3
8		F8-96-19-0-0	1/4" Lock Washer, Stainless	3	3	3
9		F8-22-19-2-0	1/4-20 Hex Nut, Stainless	3	3	3
10		F8-7-19-2-28	1/4-20 x 1-3/4" Hex Bolt, Stainless	3	3	3

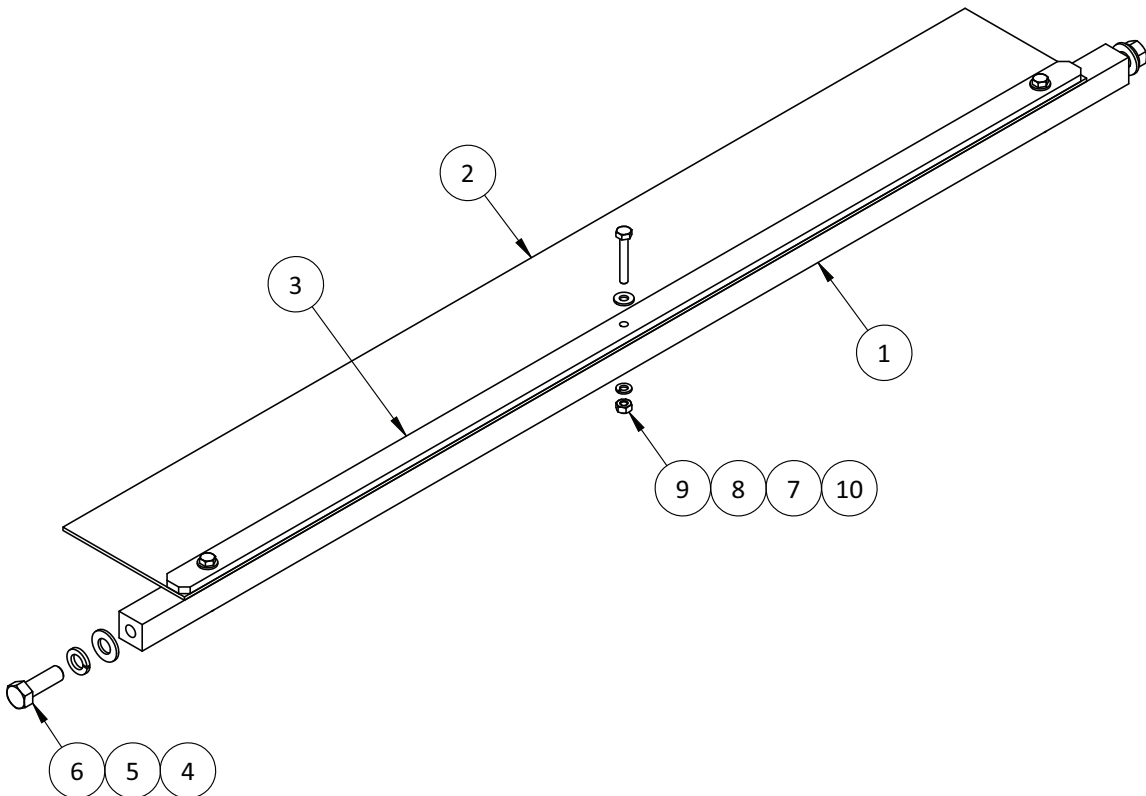

Belt Scraper Assembly			
Belt Width	Part Number	Drawing Number	Description
24	--	700 514 01 00	Belt Scraper Assembly, 24-in
36	--	702 514 01 00	Belt Scraper Assembly, 36-in
48	--	704 514 01 00	Belt Scraper Assembly, 48-in

Component Details

Support Weldment Assembly

ITEM NO.	DRAWING NO.	PART NO.	DESCRIPTION	24-in	36-in	48-in
1	702 210 01 00		Support Weldment, 36-in	-	1	-
1	700 210 01 00		Support Weldment, 24-in	1	-	-
1	704 210 01 00		Support Weldment, 48-in	-	-	1
2		F8-7-27-2-28	3/4-10 x 1-3/4" Hex Bolt, Stainless	6	6	6
3		F8-92-27-0-0	3/4" Flat Washer, Stainless	6	6	6
4		F8-96-27-0-0	3/4" Lock Washer, Stainless	6	6	6

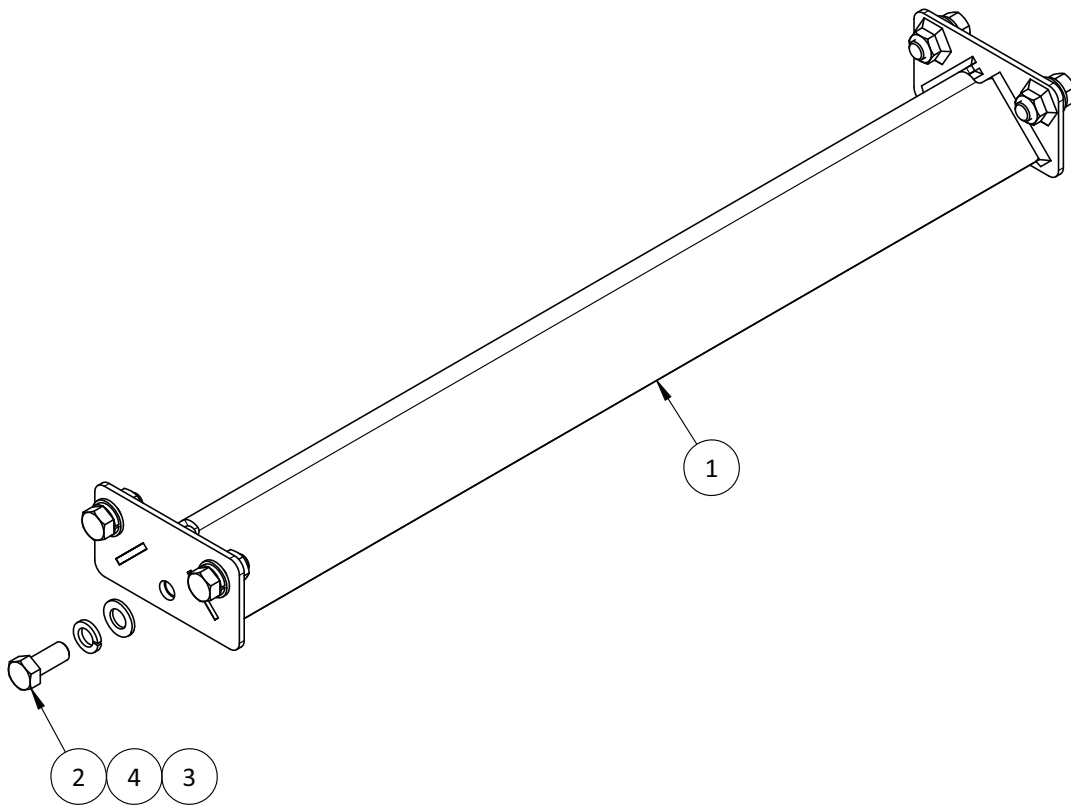

Support Weldment Assembly			
Belt Width	Part Number	Drawing Number	Description
24	--	700 510 05 00	Support Weldment Assembly, 24-in
36	--	702 510 05 00	Support Weldment Assembly, 36-in
48	--	704 510 05 00	Support Weldment Assembly, 48-in

End Unit, Front

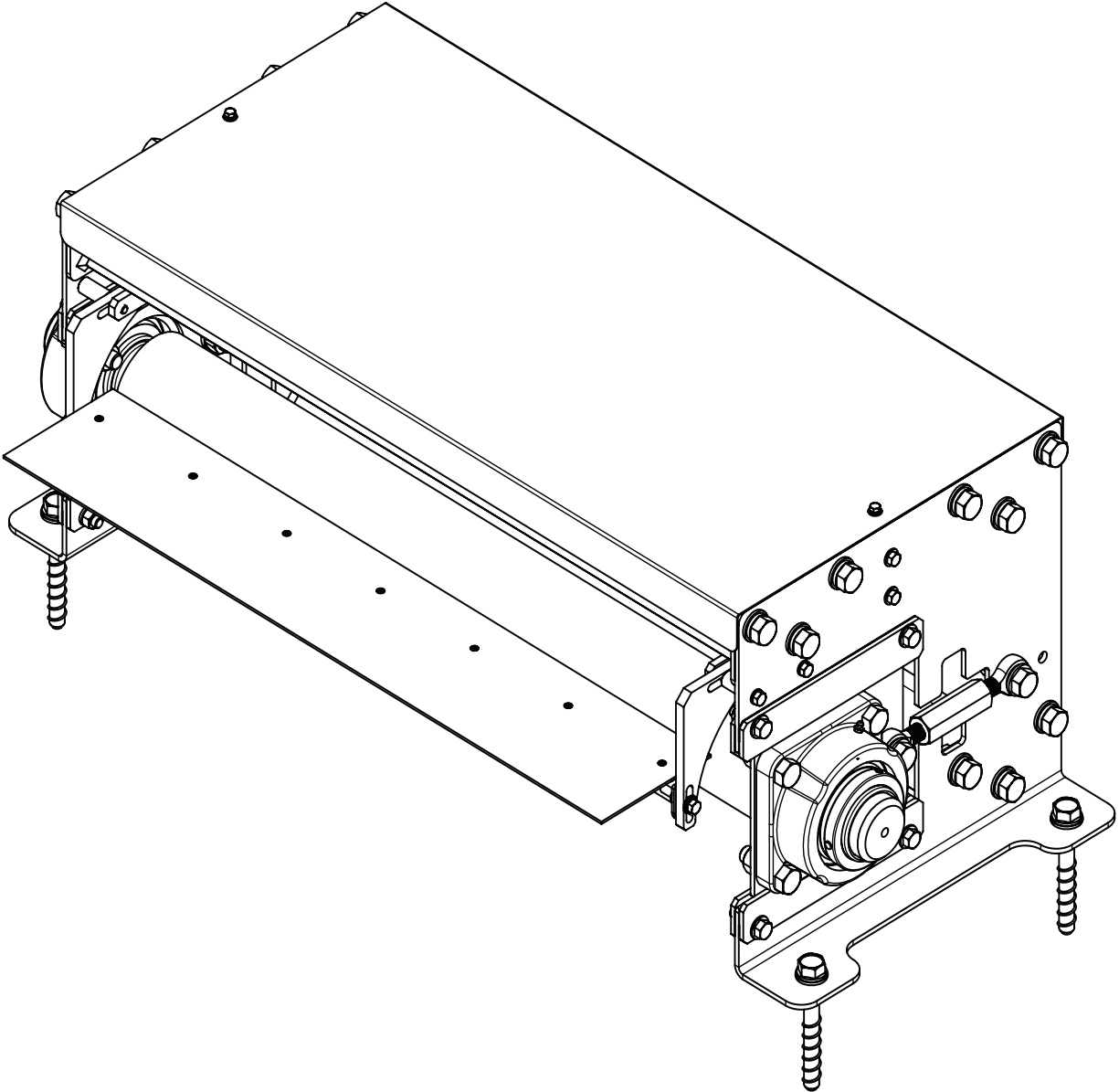

End Unit, Front			
Belt Width	Part Number	Drawing Number	Description
24	--	700 003 01 01	End Unit, Front, 24-in
36	--	702 003 01 01	End Unit, Front, 36-in
48	--	704 003 01 01	End Unit, Front, 48-in

Component Details

ITEM NO.	DRAWING NO.	PART NO.	DESCRIPTION	24-in	36-in	48-in
1	700 010 36 00		Straight Roller, 24-in	1	-	-
1	702 010 36 00		Straight Roller, 36-in	-	1	-
1	704 010 06 00		Straight Roller, 48-in	-	-	1
2	700 020 12 01		End Unit Guard, Front, 24-in	1	-	-
2	702 020 12 01		End Unit Guard, Front, 36-in	-	1	-
2	704 020 08 01		End Unit Guard, Front, 48-in	-	-	1
3	700 510 05 00		Support Weldment Assembly, 24-in	3	-	-
3	702 510 05 00		Support Weldment Assembly, 36-in	-	3	-
3	704 510 05 00		Support Weldment Assembly, 48-in	-	-	3
4	700 520 01 00		Transfer Plate Assembly, 24-in	1	-	-
4	702 520 01 00		Transfer Plate Assembly, 36-in	-	1	-
4	704 520 01 00		Transfer Plate Assembly, 48-in	-	-	1
5	704 011 03 00		Sliding Bearing Holding Plate, Short	8	8	8
6	704 011 04 00		Sliding Bearing Holding Plate Shim, Short	4	4	4
7	704 020 01 00		End Unit Side Sheet, RH	1	1	1
8	704 020 02 00		End Unit Side Sheet, LH	1	1	1
9	704 510 04 04		Drive Unit Tracking Bearing Assembly	2	2	2
10	704 510 11 00		Turnbuckle Assembly	2	2	2
11	704 520 03 01		End Unit Guard Mount Assembly	2	2	2
12		F8-7-23-2-24	1/2-13 x 1-3/4" Hex Bolt, Stainless	8	8	8
13		F8-22-23-0-0	1/2-13 Hex Nut, Stainless	8	8	8
14		F8-92-23-0-0	1/2" Flat Washer, Stainless	8	8	8
15		F8-92-27-0-0	3/4" Flat Washer, Stainless	4	4	4
16		F8-96-23-0-0	1/2" Lock Washer, Stainless	8	8	8
17		F9-77-27-0-96	3/4" x 6" Masonary Hex Head Screw, Zinc	4	4	4

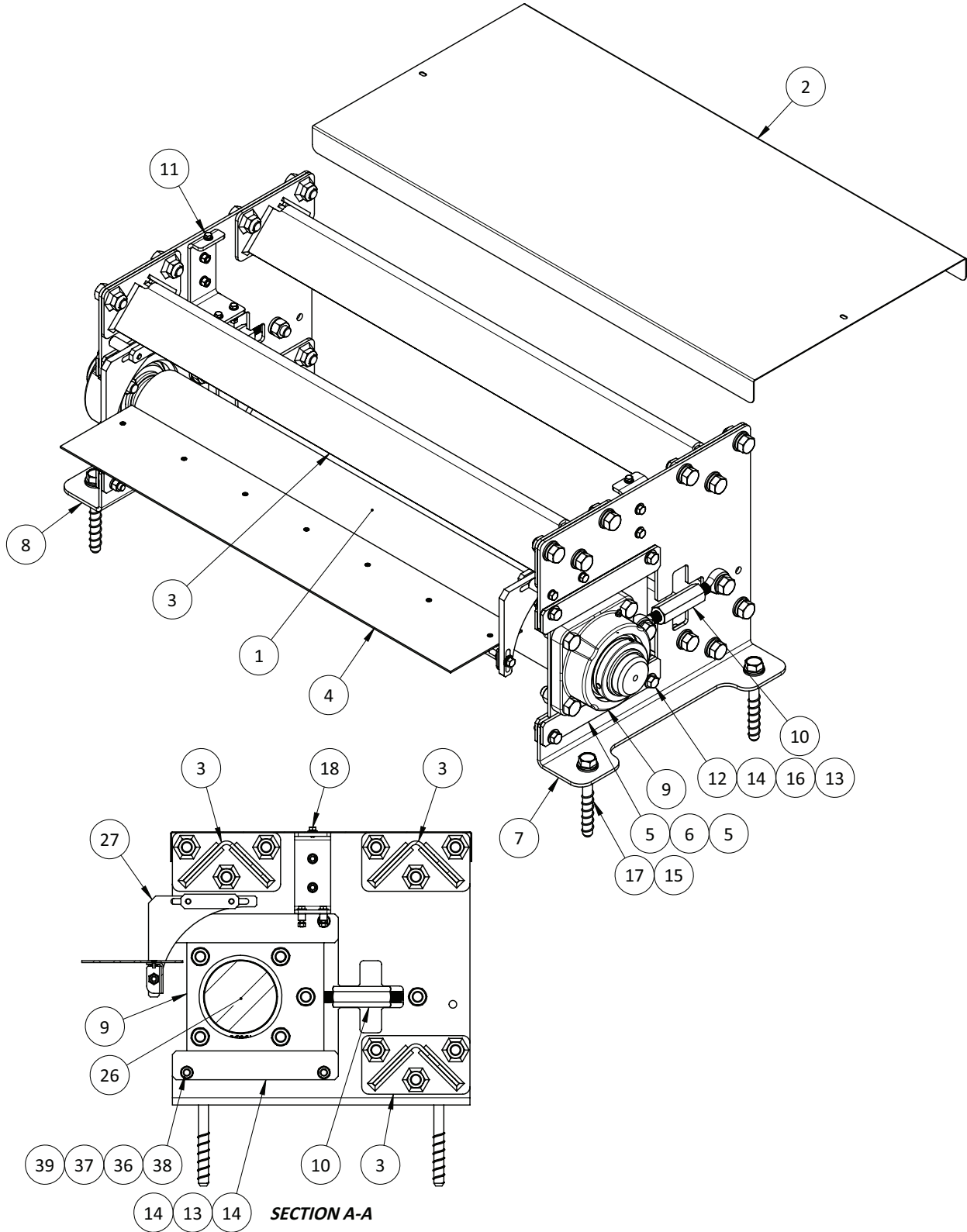

Component Details

Drive Unit Tracking Bearing Assembly

ITEM NO.	DRAWING NO.	PART NO.	DESCRIPTION	QTY.
1	704 010 03 00		Bearing Slide Plate, Tracking	1
2	704 010 25 00	SEE CHART	4-Bolt Flange Bearing, 3-in	1
3		F8-7-27-2-40	3/4-10 x 2-1/2" Hex Bolt, Stainless	4
4		F8-22-27-0-0	3/4-10 Hex Nut, Stainless	4
5		F8-96-27-0-0	3/4" Lock Washer, Stainless	4

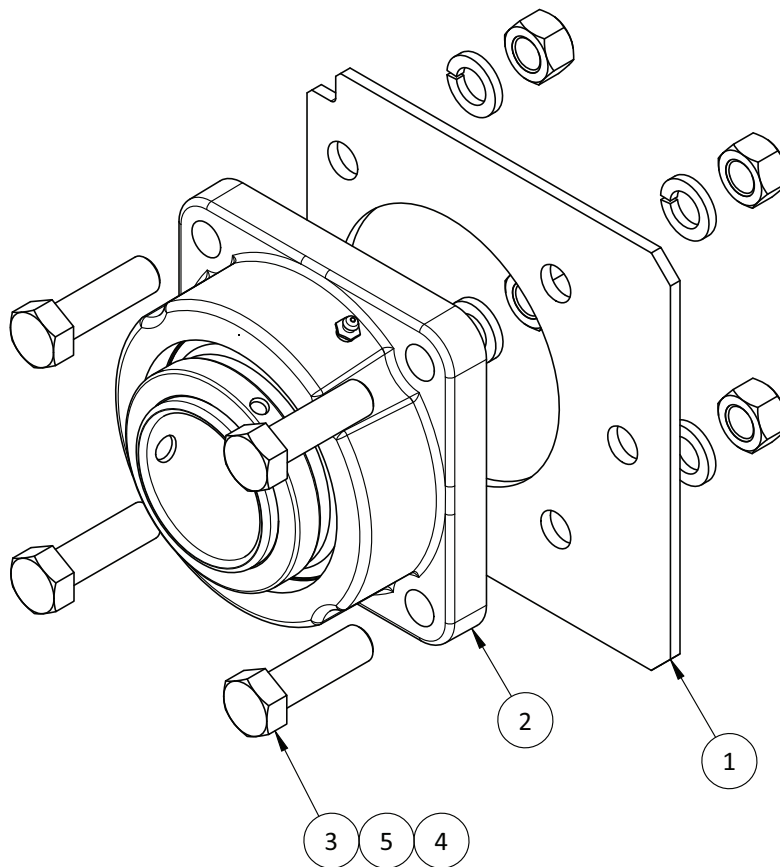

Drive Unit Tracking Bearing Assembly			
Belt Width	Part Number	Drawing Number	Description
24	--	704 510 04 04	Drive Unit Tracking Bearing Assembly
36			
48			

Turnbuckle Assembly

ITEM NO.	DRAWING NO.	PART NO.	DESCRIPTION	QTY.
1	704 010 07 00		Turnbuckle Body	1
2		59915K278	RH Rod End	1
3		59915K282	LH Rod End	1
4		F8-7-27-2-40	3/4-10 x 2-1/2" Hex Bolt, Stainless	2
5		F8-22-27-0-0	3/4-10 Hex Nut, Stainless	2
6		F8-92-27-0-0	3/4" Flat Washer, Stainless	2
7		F8-96-27-0-0	3/4" Lock Washer, Stainless	2

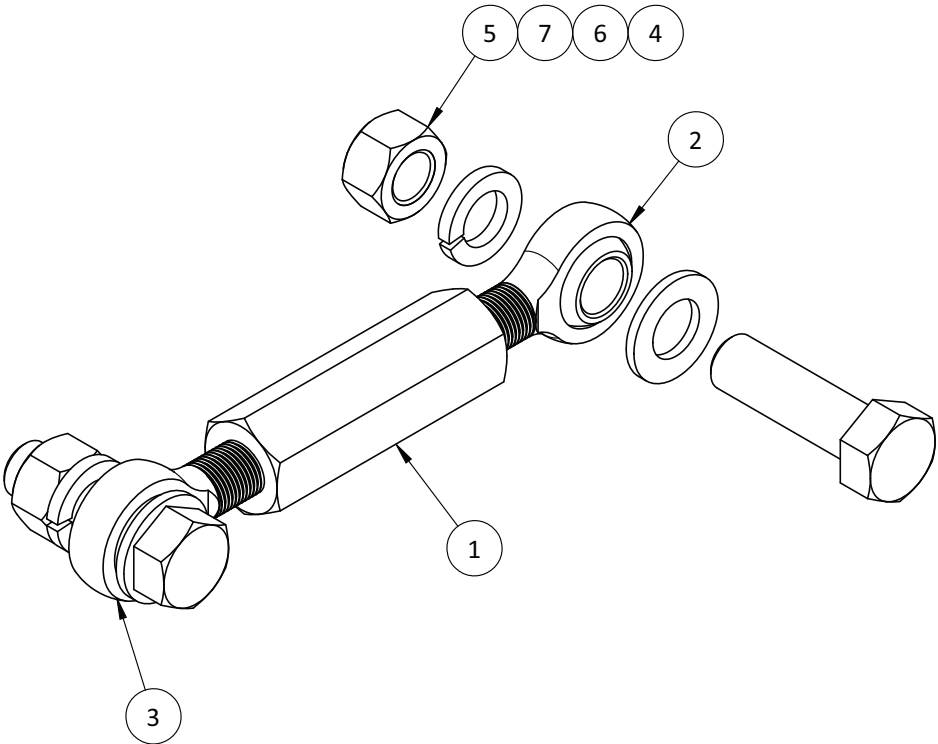

Turnbuckle Assembly			
Belt Width	Part Number	Drawing Number	Description
24	--	704 510 11 00	Turnbuckle Assembly
36			
48			

Component Details

Support Weldment Assembly

ITEM NO.	DRAWING NO.	PART NO.	DESCRIPTION	24-in	36-in	48-in
1	702 210 01 00		Support Weldment, 36-in	-	1	-
1	700 210 01 00		Support Weldment, 24-in	1	-	-
1	704 210 01 00		Support Weldment, 48-in	-	-	1
2		F8-7-27-2-28	3/4-10 x 1-3/4" Hex Bolt, Stainless	6	6	6
3		F8-92-27-0-0	3/4" Flat Washer, Stainless	6	6	6
4		F8-96-27-0-0	3/4" Lock Washer, Stainless	6	6	6

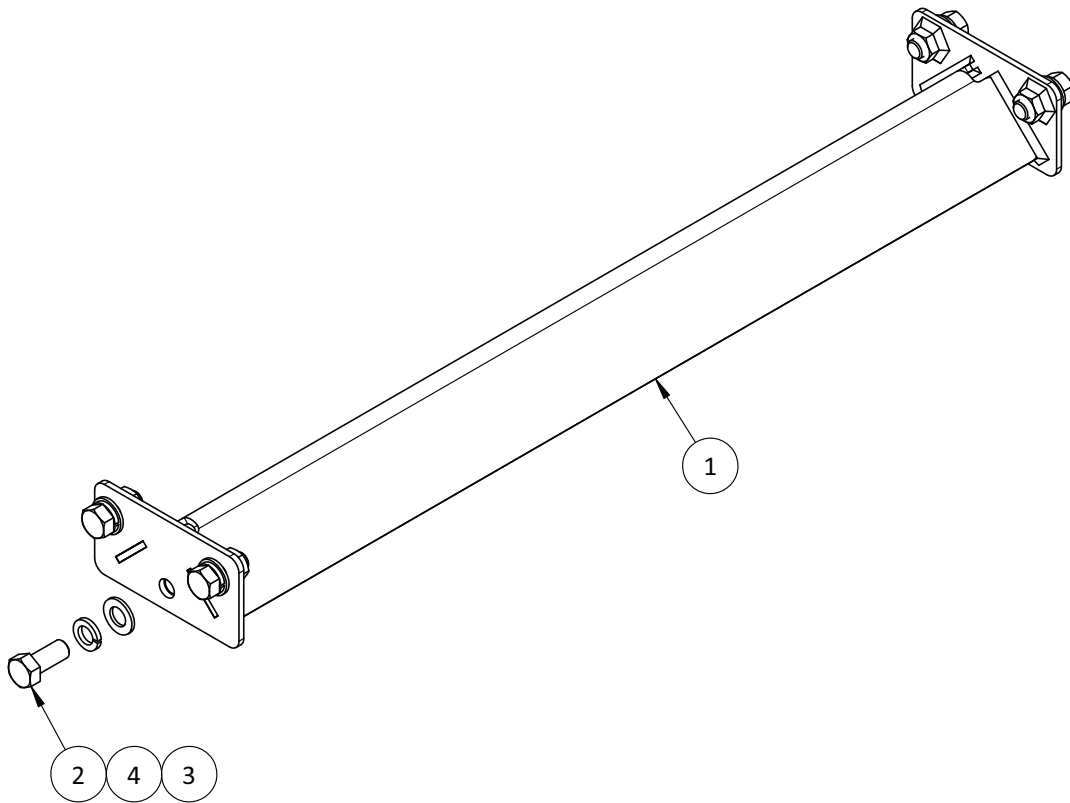

Support Weldment Assembly			
Belt Width	Part Number	Drawing Number	Description
24	--	700 510 05 00	Support Weldment Assembly, 24-in
36	--	702 510 05 00	Support Weldment Assembly, 36-in
48	--	704 510 05 00	Support Weldment Assembly, 48-in

Transfer Plate Assembly

ITEM NO.	DRAWING NO.	PART NO.	DESCRIPTION	24-in	36-in	48-in
1	704 020 03 00		Transfer Adjustment Bracket	2	2	2
2	700 020 09 00		Transfer Plate, 24-in	1	-	-
2	702 020 09 00		Transfer Plate, 36-in	-	1	-
2	704 020 04 00		Transfer Plate, 48-in	-	-	1
3	704 020 05 00		Transfer Adjustment Nut Plate	2	2	2
4	704 020 06 00		Transfer Standoff	4	4	4
5	700 020 10 00		Transfer Support Weldment, 24-in	1	-	-
5	702 020 10 00		Transfer Support Weldment, 36-in	-	1	-
5	704 020 11 00		Transfer Support Weldment, 48-in	-	-	1
6		F8-7-21-2-20	3/8-16 x 1-1/4" Hex Bolt, Stainless	2	2	2
7		F8-7-21-2-48	3/8-16 x 3" Hex Bolt, Stainless	4	4	4
8		F8-61-8-3-8	#10-32 x 1/2" Flat Head Phillips Screw, Stainless	5	7	9
9		F8-92-21-0-0	3/8" Flat Washer, Stainless	6	6	6
10		F8-96-21-0-0	3/8" Lock Washer, Stainless	6	6	6

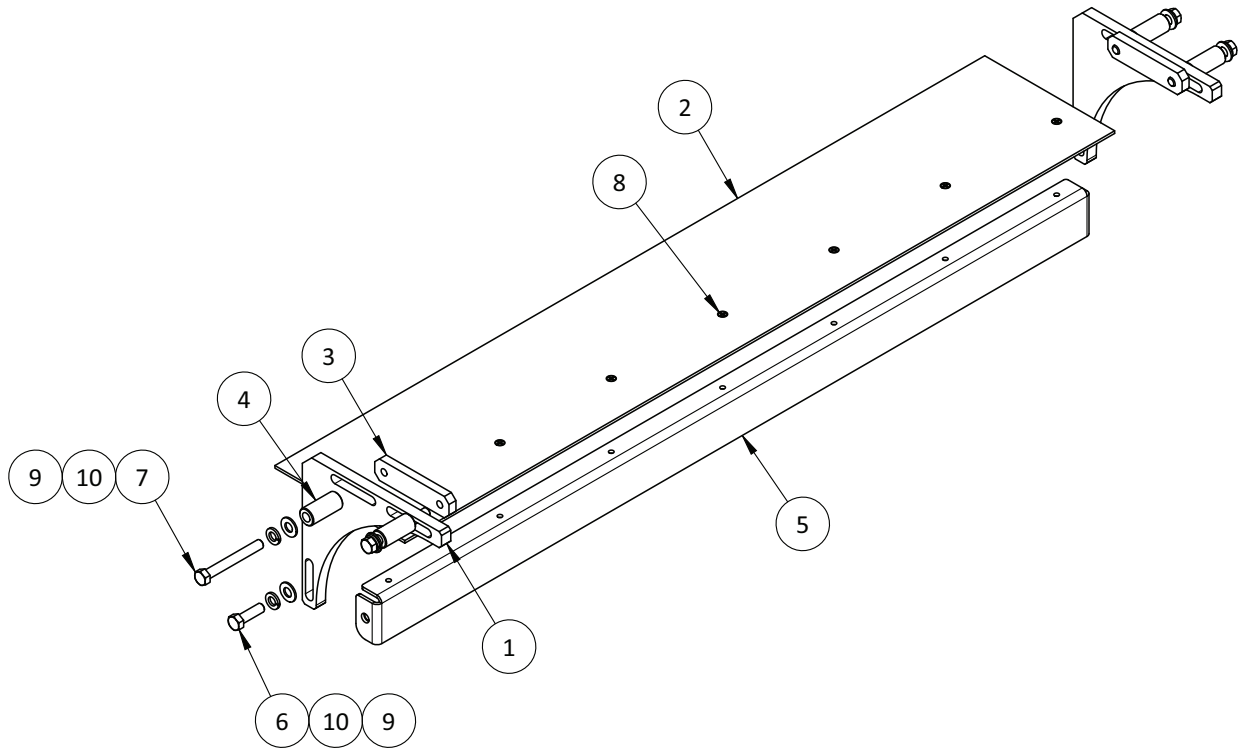

Transfer Plate Assembly			
Belt Width	Part Number	Drawing Number	Description
24	--	700 520 01 00	Transfer Plate Assembly, 24-in
36	--	702 520 01 00	Transfer Plate Assembly, 36-in
48	--	704 520 01 00	Transfer Plate Assembly, 48-in

Component Details

End Unit Guard Mount Assembly

ITEM NO.	DRAWING NO.	PART NO.	DESCRIPTION	QTY.
1	704 020 07 01		End Unit Guard Bracket	1
2	704 020 10 00		Guard Bracket Spacer	2
3		F8-7-19-2-8	1/4-20 x 1/2" Hex Bolt, Stainless	1
4		F8-7-19-2-20	1/4-20 x 1-1/4" Hex Bolt, Stainless	2
5		F8-7-21-2-16	3/8-16 x 1" Hex Bolt, Stainless	2
6		F8-22-19-2-0	1/4-20 Hex Nut, Stainless	2
7		F8-22-21-0-0	3/8-16 Hex Nut, Stainless	2
8		F8-92-19-0-0	1/4" Flat Washer, Stainless	3
9		F8-92-21-0-0	3/8" Flat Washer, Stainless	2
10		F8-96-19-0-0	1/4" Lock Washer, Stainless	3
11		F8-96-21-0-0	3/8" Lock Washer, Stainless	2

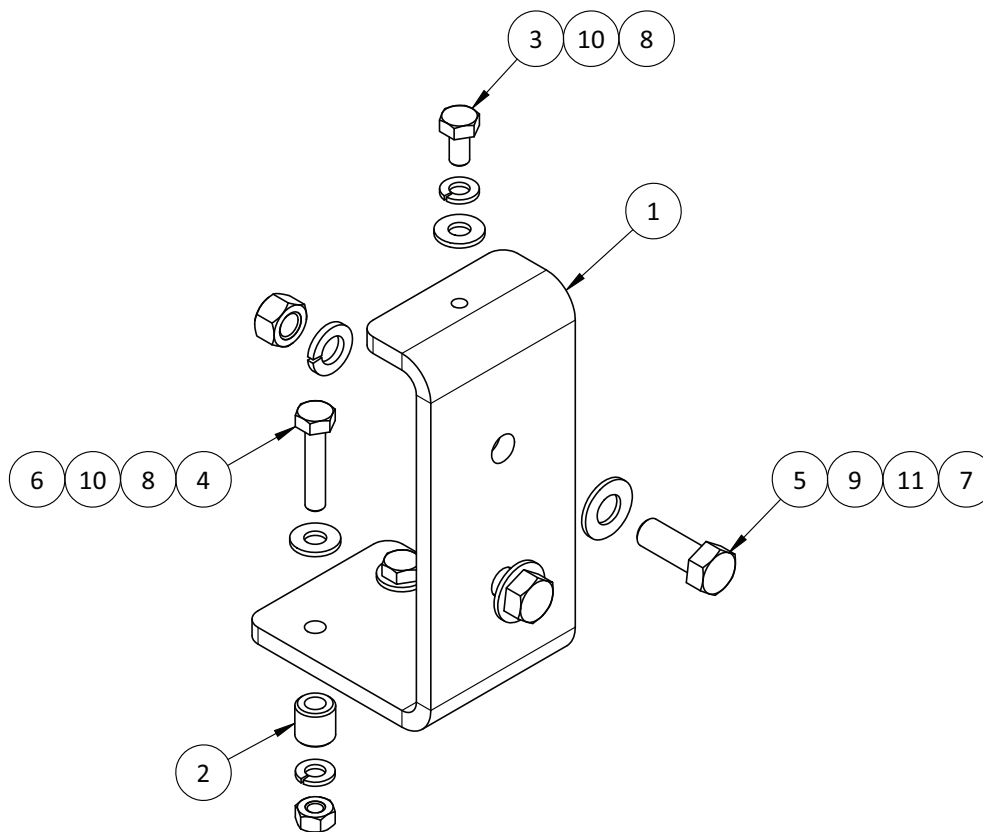

End Unit Guard Mount Assembly			
Belt Width	Part Number	Drawing Number	Description
24	--	704 520 03 01	End Unit Guard Mount Assembly
36			
48			

End Unit, Back

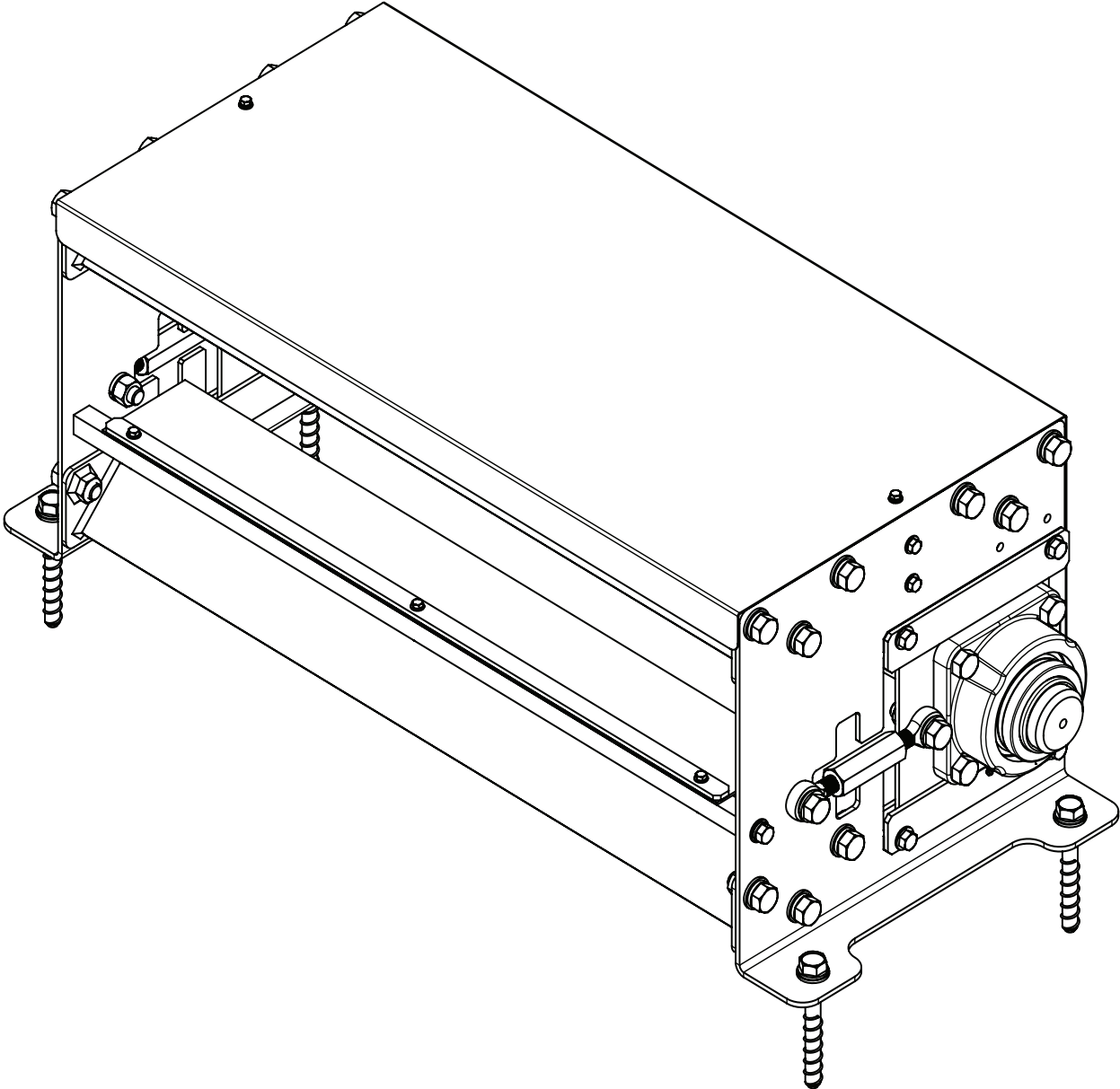

End Unit, Back			
Belt Width	Part Number	Drawing Number	Description
24	--	700 002 01 01	End Unit, Back, 24-in
36	--	702 002 01 01	End Unit, Back, 36-in
48	--	704 002 01 01	End Unit, Back, 48-in

Component Details

ITEM NO.	DRAWING NO.	PART NO.	DESCRIPTION	24-in	36-in	48-in
1	700 010 37 00		Tapered Roller, 24-in	1	-	-
1	702 010 37 00		Tapered Roller, 36-in	-	1	-
1	704 010 05 00		Tapered Roller, 48-in	-	-	1
2	700 020 11 01		End Unit Guard, Back, 24-in	1	-	-
2	702 020 11 01		End Unit Guard, Back, 36-in	-	1	-
2	704 020 09 01		End Unit Guard, Back, 48-in	-	-	1
3	700 510 05 00		Support Weldment Assembly, 24-in	3	-	-
3	702 510 05 00		Support Weldment Assembly, 36-in	-	3	-
3	704 510 05 00		Support Weldment Assembly, 48-in	-	-	3
4	700 514 01 00		Belt Scraper Assembly, 24-in	1	-	-
4	702 514 01 00		Belt Scraper Assembly, 36-in	-	1	-
4	704 514 01 00		Belt Scraper Assembly, 48-in	-	-	1
5	704 011 03 00		Sliding Bearing Holding Plate, Short	8	8	8
6	704 011 04 00		Sliding Bearing Holding Plate Shim, Short	4	4	4
7	704 020 01 00		End Unit Side Sheet, RH	1	1	1
8	704 020 02 00		End Unit Side Sheet, LH	1	1	1
9	704 510 04 04		Drive Unit Tracking Bearing Assembly	2	2	2
10	704 510 11 00		Turnbuckle Assembly	2	2	2
11	704 520 03 01		End Unit Guard Mount Assembly	2	2	2
12		F8-7-23-2-24	1/2-13 x 1-3/4" Hex Bolt, Stainless	8	8	8
13		F8-22-23-0-0	1/2-13 Hex Nut, Stainless	8	8	8
14		F8-92-23-0-0	1/2" Flat Washer, Stainless	8	8	8
15		F8-92-27-0-0	3/4" Flat Washer, Stainless	4	4	4
16		F8-96-23-0-0	1/2" Lock Washer, Stainless	8	8	8
17		F9-77-27-0-96	3/4" x 6" Masonary Hex Head Screw, Zinc	4	4	4

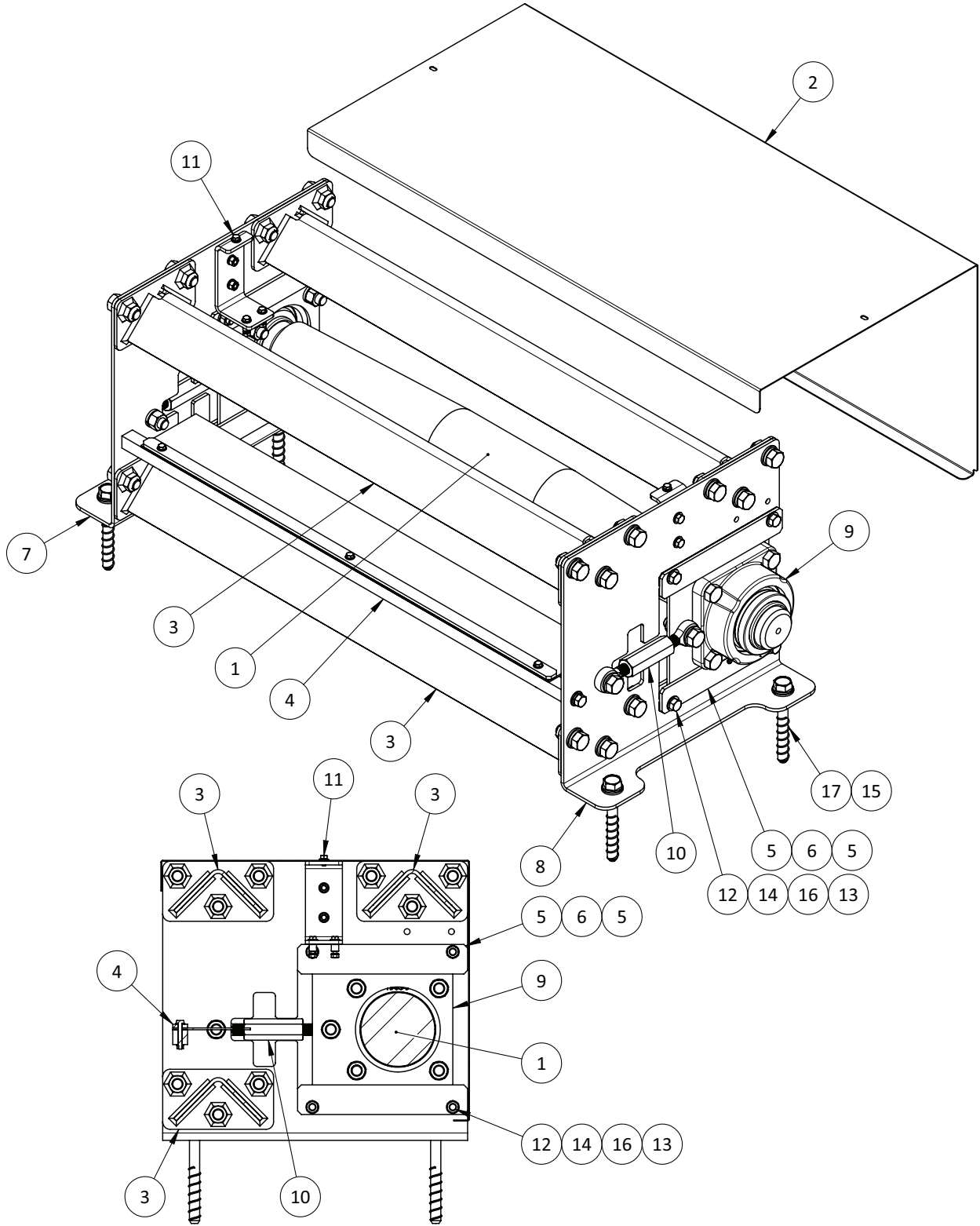

SECTION A-A

Component Details

Drive Unit Tracking Bearing Assembly

ITEM NO.	DRAWING NO.	PART NO.	DESCRIPTION	QTY.
1	704 010 03 00		Bearing Slide Plate, Tracking	1
2	704 010 25 00	SEE CHART	4-Bolt Flange Bearing, 3-in	1
3		F8-7-27-2-40	3/4-10 x 2-1/2" Hex Bolt, Stainless	4
4		F8-22-27-0-0	3/4-10 Hex Nut, Stainless	4
5		F8-96-27-0-0	3/4" Lock Washer, Stainless	4

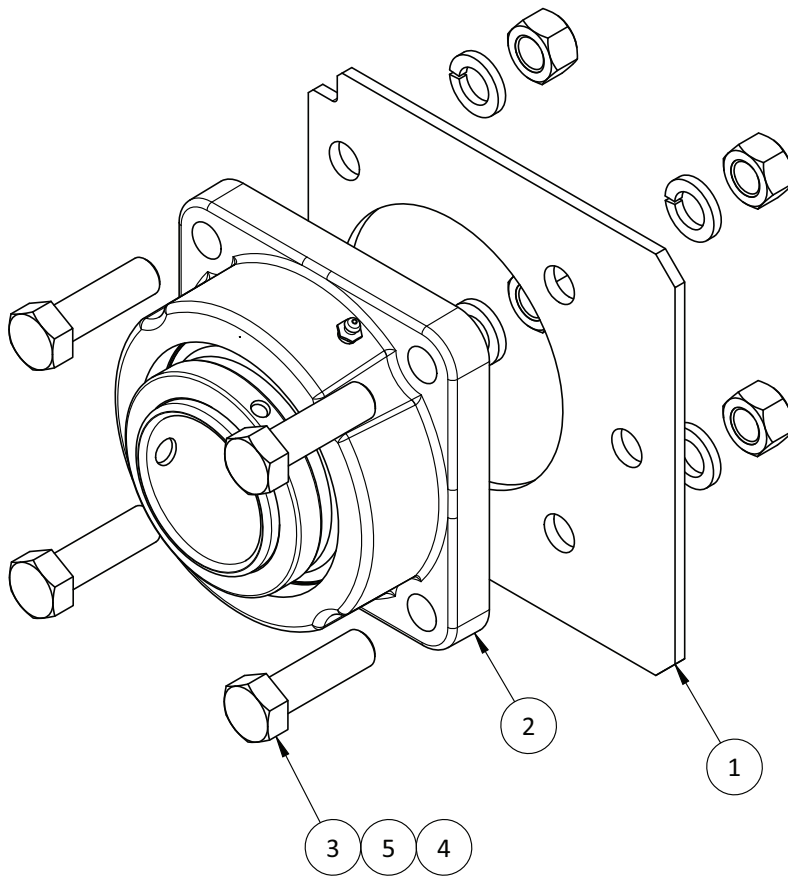

Drive Unit Tracking Bearing Assembly			
Belt Width	Part Number	Drawing Number	Description
24	--	704 510 04 04	Drive Unit Tracking Bearing Assembly
36			
48			

Turnbuckle Assembly

ITEM NO.	DRAWING NO.	PART NO.	DESCRIPTION	QTY.
1	704 010 07 00		Turnbuckle Body	1
2		59915K278	RH Rod End	1
3		59915K282	LH Rod End	1
4		F8-7-27-2-40	3/4-10 x 2-1/2" Hex Bolt, Stainless	2
5		F8-22-27-0-0	3/4-10 Hex Nut, Stainless	2
6		F8-92-27-0-0	3/4" Flat Washer, Stainless	2
7		F8-96-27-0-0	3/4" Lock Washer, Stainless	2

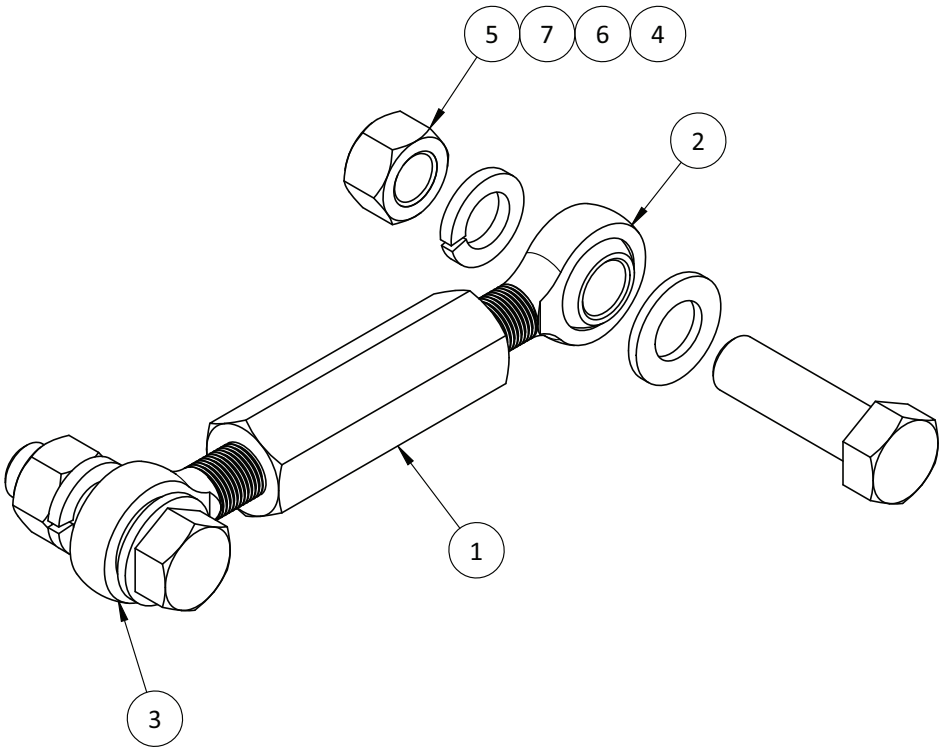

Turnbuckle Assembly			
Belt Width	Part Number	Drawing Number	Description
24	--	704 510 11 00	Turnbuckle Assembly
36			
48			

Component Details

Support Weldment Assembly

ITEM NO.	DRAWING NO.	PART NO.	DESCRIPTION	24-in	36-in	48-in
1	702 210 01 00		Support Weldment, 36-in	-	1	-
1	700 210 01 00		Support Weldment, 24-in	1	-	-
1	704 210 01 00		Support Weldment, 48-in	-	-	1
2		F8-7-27-2-28	3/4-10 x 1-3/4" Hex Bolt, Stainless	6	6	6
3		F8-92-27-0-0	3/4" Flat Washer, Stainless	6	6	6
4		F8-96-27-0-0	3/4" Lock Washer, Stainless	6	6	6

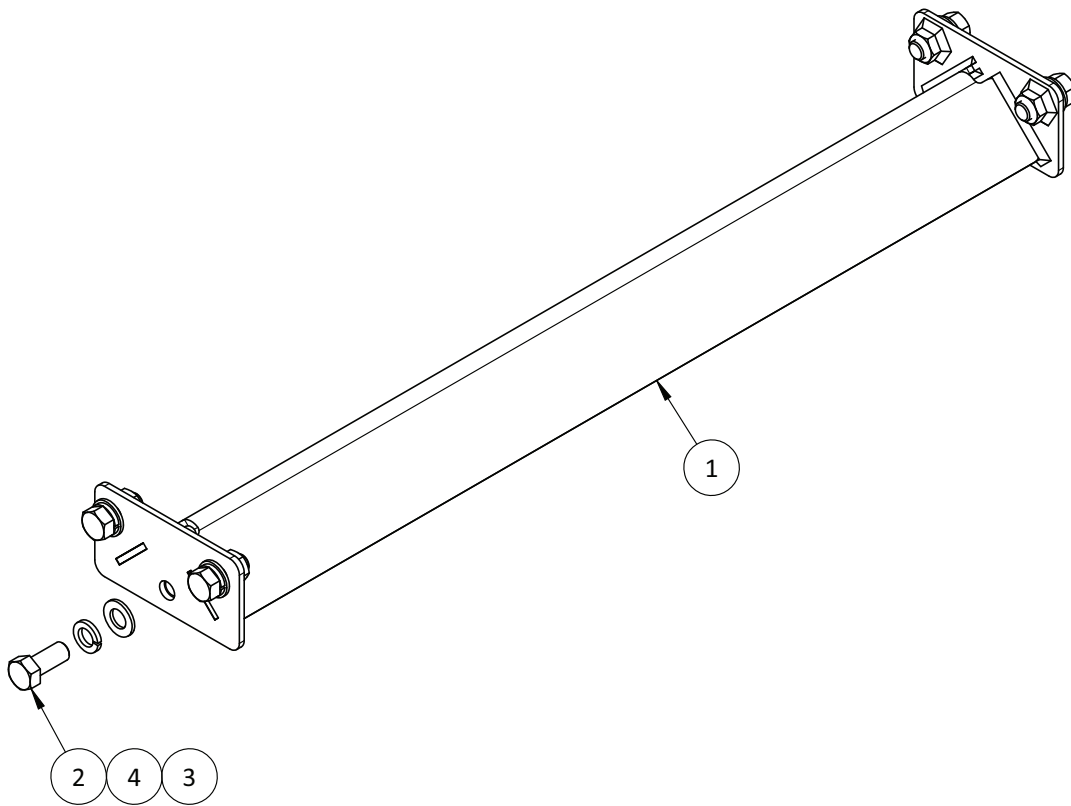

Support Weldment Assembly			
Belt Width	Part Number	Drawing Number	Description
24	--	700 510 05 00	Support Weldment Assembly, 24-in
36	--	702 510 05 00	Support Weldment Assembly, 36-in
48	--	704 510 05 00	Support Weldment Assembly, 48-in

Belt Scraper Assembly

ITEM NO.	DRAWING NO.	PART NO.	DESCRIPTION	24-in	36-in	48-in
1	700 214 01 00		Belt Scraper Support Bar, 24-in	1	-	-
1	702 214 01 00		Belt Scraper Support Bar, 36-in	-	1	-
1	704 214 01 00		Belt Scraper Support Bar, 48-in	-	-	1
2	700 214 02 00		Belt Scraper Plate, 24-in	1	-	-
2	702 214 02 00		Belt Scraper Plate, 36-in	-	1	-
2	704 214 02 00		Belt Scraper Plate, 48-in	-	-	1
3	700 214 03 00		Belt Scraper Holding Plate, 24-in	1	-	-
3	702 214 03 00		Belt Scraper Holding Plate, 36-in	-	1	-
3	704 214 03 00		Belt Scraper Holding Plate, 48-in	-	-	1
4		F8-92-23-0-0	1/2" Flat Washer, Stainless	2	2	2
5		F8-96-23-0-0	1/2" Lock Washer, Stainless	2	2	2
6		F8-7-23-2-24	1/2-13 x 1-1/2" Hex Bolt, Stainless	2	2	2
7		F8-92-19-0-0	1/4" Flat Washer, Stainless	3	3	3
8		F8-96-19-0-0	1/4" Lock Washer, Stainless	3	3	3
9		F8-22-19-2-0	1/4-20 Hex Nut, Stainless	3	3	3
10		F8-7-19-2-28	1/4-20 x 1-3/4" Hex Bolt, Stainless	3	3	3

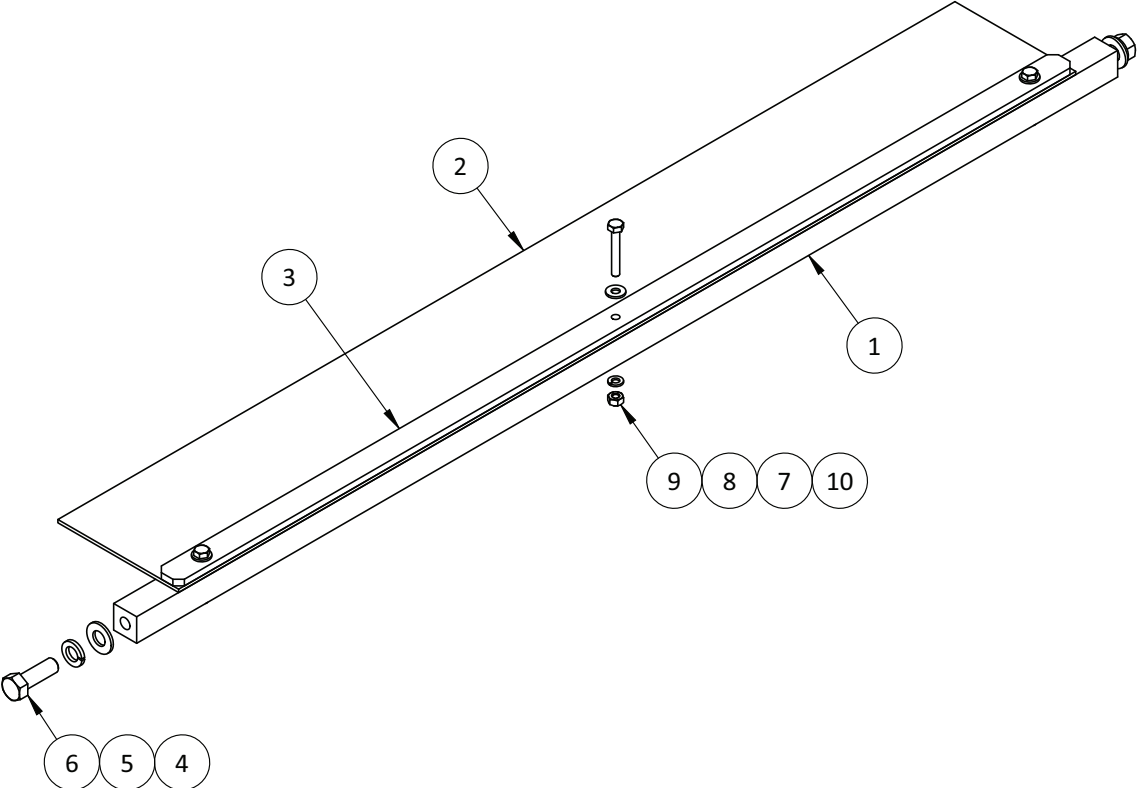

Belt Scraper Assembly			
Belt Width	Part Number	Drawing Number	Description
24	--	700 514 01 00	Belt Scraper Assembly, 24-in
36	--	702 514 01 00	Belt Scraper Assembly, 36-in
48	--	704 514 01 00	Belt Scraper Assembly, 48-in

Component Details

End Unit Guard Mount Assembly

ITEM NO.	DRAWING NO.	PART NO.	DESCRIPTION	QTY.
1	704 020 07 01		End Unit Guard Bracket	1
2	704 020 10 00		Guard Bracket Spacer	2
3		F8-7-19-2-8	1/4-20 x 1/2" Hex Bolt, Stainless	1
4		F8-7-19-2-20	1/4-20 x 1-1/4" Hex Bolt, Stainless	2
5		F8-7-21-2-16	3/8-16 x 1" Hex Bolt, Stainless	2
6		F8-22-19-2-0	1/4-20 Hex Nut, Stainless	2
7		F8-22-21-0-0	3/8-16 Hex Nut, Stainless	2
8		F8-92-19-0-0	1/4" Flat Washer, Stainless	3
9		F8-92-21-0-0	3/8" Flat Washer, Stainless	2
10		F8-96-19-0-0	1/4" Lock Washer, Stainless	3
11		F8-96-21-0-0	3/8" Lock Washer, Stainless	2

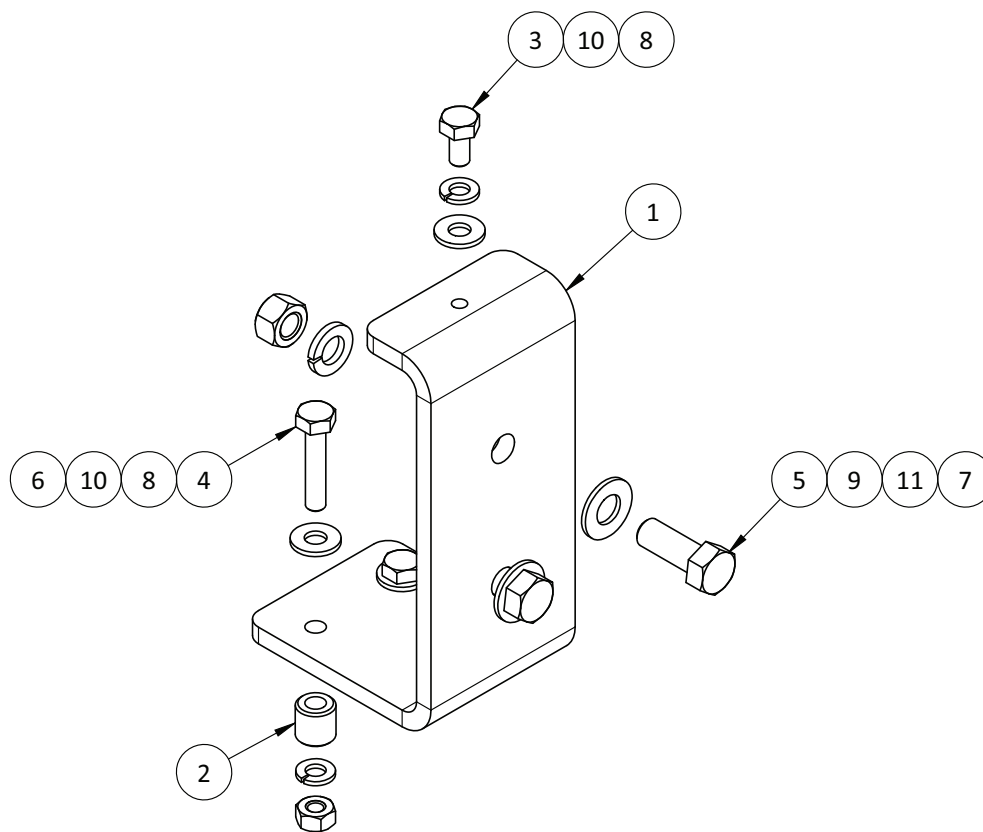

End Unit Guard Mount Assembly			
Belt Width	Part Number	Drawing Number	Description
24	--	704 520 03 01	End Unit Guard Mount Assembly
36			
48			

Connecting Part

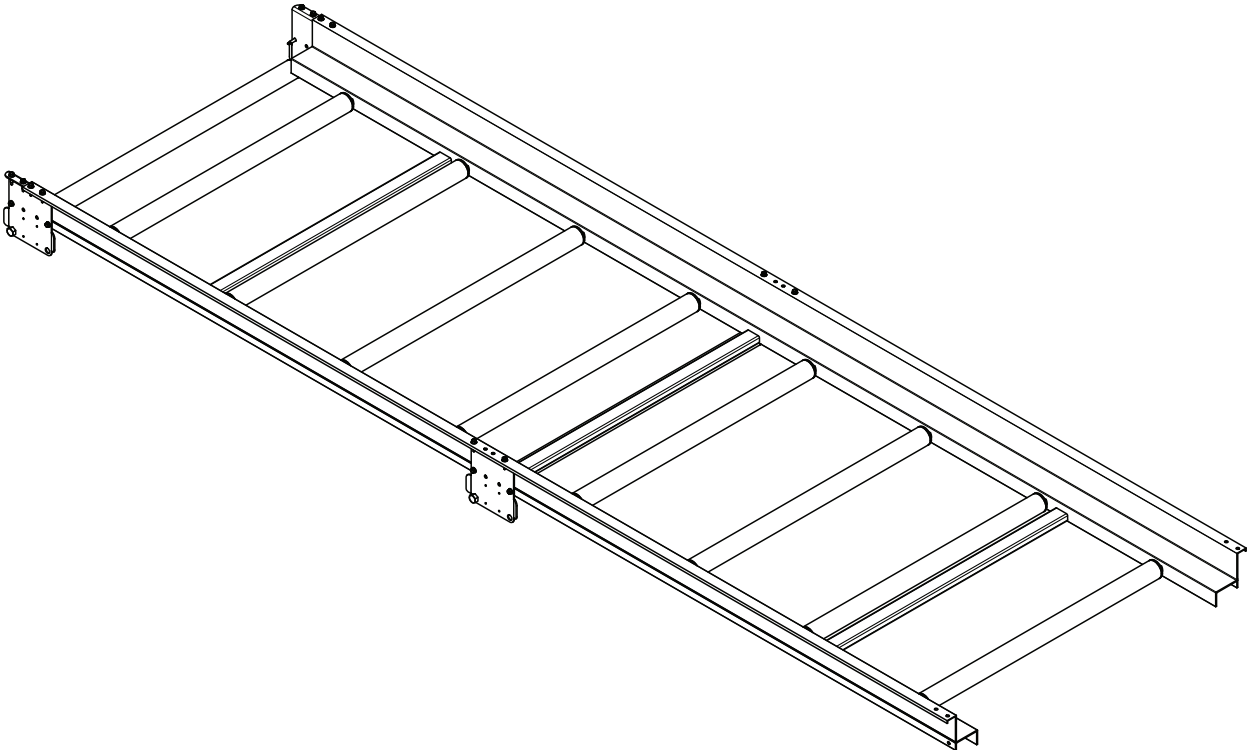

Connecting Part			
Belt Width	Part Number	Drawing Number	Description
24	--	700 005 05 00	Connecting Part, 24-in
36	--	702 005 05 06	Connecting Part, 36-in
48	--	704 004 01 00	Connecting Part, 48-in

Component Details

ITEM NO.	DRAWING NO.	PART NO.	DESCRIPTION	24-in	36-in	48-in
1	700 030 01 01		Traverse, 24-in	3	-	-
1	188 524 05 00		Traverse T750	-	3	-
1	704 030 01 00		Traverse, 48-in	-	-	3
2	700 130 01 04		Top Roller Assembly, 24-in	8	-	-
2	702 130 01 04		Top Roller Assembly, 36-in	-	8	-
2	704 130 01 00		Top Roller Assembly, 48-in	-	-	8
3	700 130 02 04		Bottom Roller Assembly, 24-in	2	-	-
3	702 130 02 04		Bottom Roller Assembly, 36-in	-	2	-
3	704 130 02 00		Bottom Roller Assembly, 48-in	-	-	2
4	702 030 06 00		Side Sheet, 10-ft	2	2	2
5	702 030 08 00		Connecting Plate	4	4	4
6		21 69 041	M6.3 x 32 Self Tapping Screw, Zinc	12	12	12
7		90594A033	1/2-13 x 3/8 Tab Base Weld Nut	20	20	20
8		F9-7-23-2-24	1/2-13 x 1-1/2" Hex Bolt, Zinc	20	20	20
9		F9-66-19-0-12	1/4" x 3/4" Hex Head Self-Tapping Screw, Zinc	20	20	20

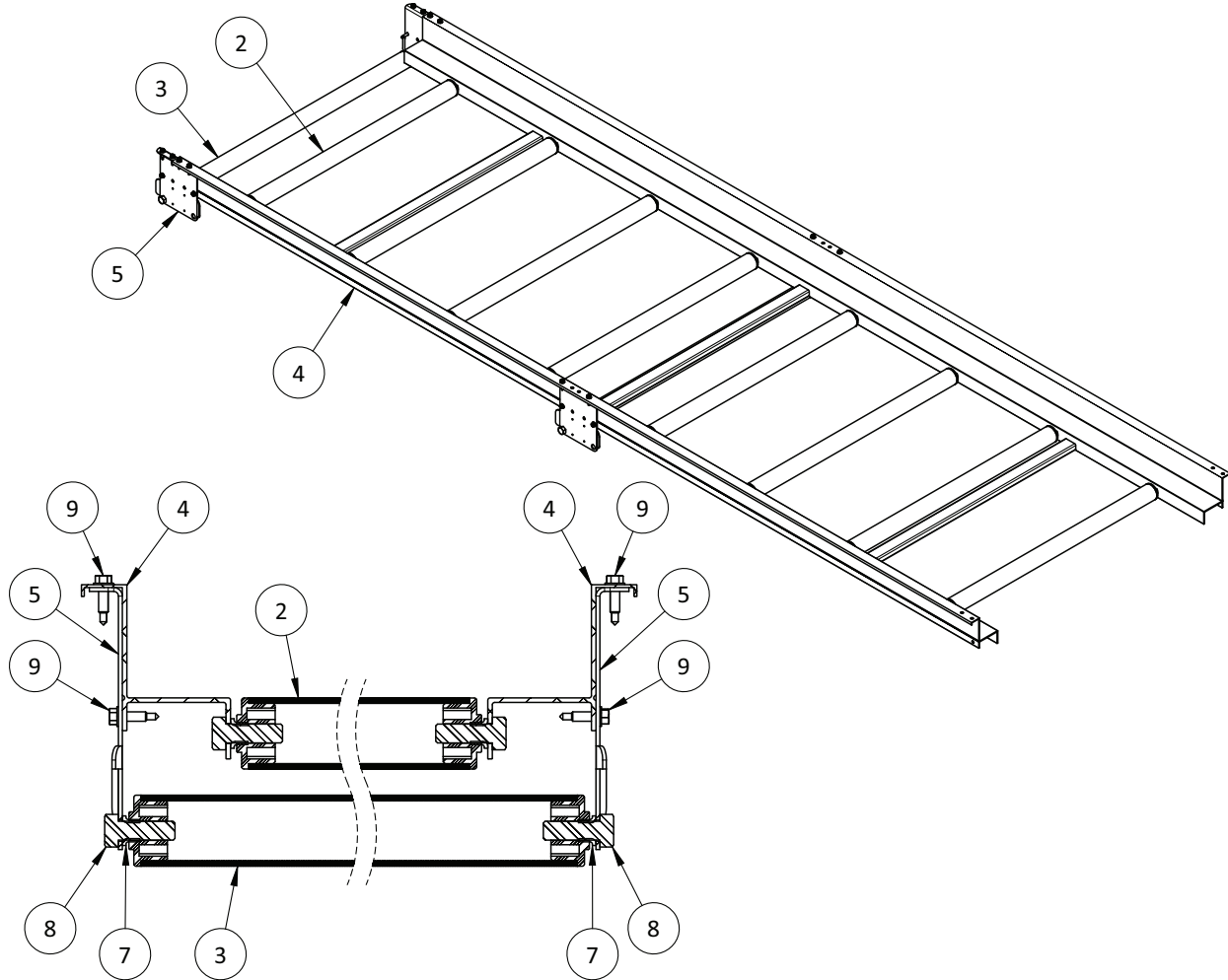

Adjustable Feet Kit (Optional)

ITEM NO.	DRAWING NO.	PART NO.	DESCRIPTION	QTY.
1	702 031 02 00		Adjustable Foot	2
2		21 69 041	M6.3 x 32 Self Tapping Screw, Zinc	2
3		F9-66-19-0-12	1/4" x 3/4" Hex Head Self-Tapping Screw, Zinc	8

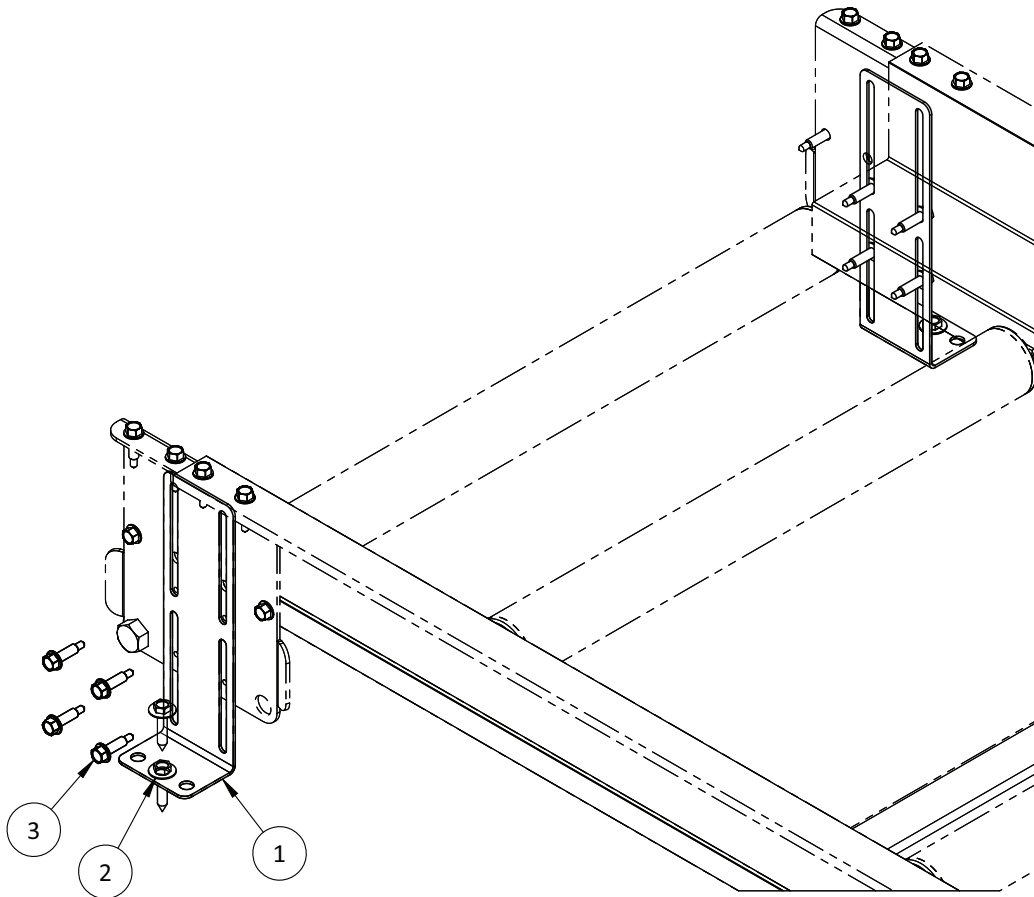

IF USING ADJUSTABLE FEET, (1) KIT REQUIRED PER CONNECTING PART

Adjustable Feet Kit			
Belt Width	Part Number	Drawing Number	Description
24	--	704 131 01 00	Adjustable Feet Kit
36			
48			

Modular Take-Up Unit (Optional)

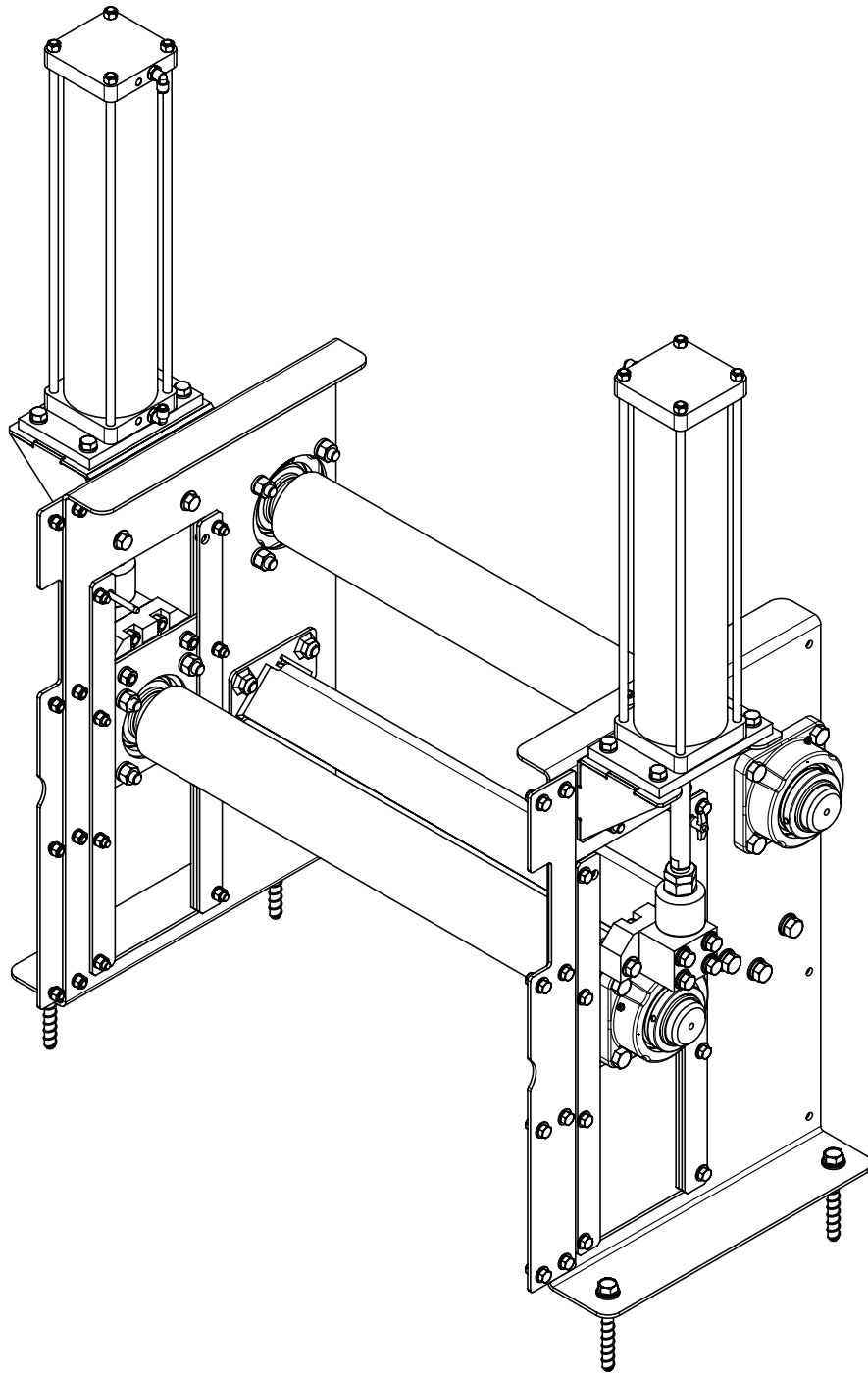

Modular Take-up Unit			
Belt Width	Part Number	Drawing Number	Description
24	--	700 006 01 01	Modular Take-up Unit, 24-in
36	--	702 006 01 01	Modular Take-up Unit, 36-in
48	--	704 006 01 01	Modular Take-up Unit, 48-in

Component Details

ITEM NO.	DRAWING NO.	PART NO.	DESCRIPTION	24-in	36-in	48-in
1	700 010 36 00		Straight Roller, 24-in	2	-	-
1	702 010 36 00		Straight Roller, 36-in	-	2	-
1	704 010 06 00		Straight Roller, 48-in	-	-	2
2	702 015 01 00		Modular Take-up Sidesheet, LH	1	1	1
3	702 015 02 00		Modular Take-up Sidesheet, RH	1	1	1
4	702 015 03 00		Modular Takeup Connecting Plate	2	2	2
5	702 015 04 00		Sliding Bearing Holding Plate, Modular Take-up	8	8	8
6	702 015 05 00		Sliding Bearing Holding Plate Shim, Modular Take-up	4	4	4
7	700 510 05 00		Support Weldment Assembly, 24-in	1	-	-
7	702 510 05 00		Support Weldment Assembly, 36-in	-	1	-
7	704 510 05 00		Support Weldment Assembly, 48-in	-	-	1
8	704 011 07 00	See Chart	3/8" Quick Pin 3-in Length	2	2	2
9	704 510 04 01		Fixed Bearing Assembly	2	2	2
10	704 510 04 03		Drive Unit Take-up Bearing Assembly	2	2	2
11	704 511 03 01		Cylinder Assembly	2	2	2
12		TIUB11B-20	Polyurethane Tubing, 3/8", 20m Roll	1	1	1
13		F8-7-23-2-20	1/2-13 x 1-1/4" Hex Bolt, Stainless	16	16	16
14		F8-7-23-2-24	1/2-13 x 1-3/4" Hex Bolt, Stainless	16	16	16
15		F8-22-23-0-0	1/2-13 Hex Nut, Stainless	32	32	32
16		F8-92-23-0-0	1/2" Flat Washer, Stainless	32	32	32
17		F8-92-27-0-0	3/4" Flat Washer, Stainless	4	4	4
18		F8-96-23-0-0	1/2" Lock Washer, Stainless	32	32	32
19		F9-77-27-0-96	3/4" x 6" Masonry Hex Head Screw, Zinc	4	4	4

Component Details

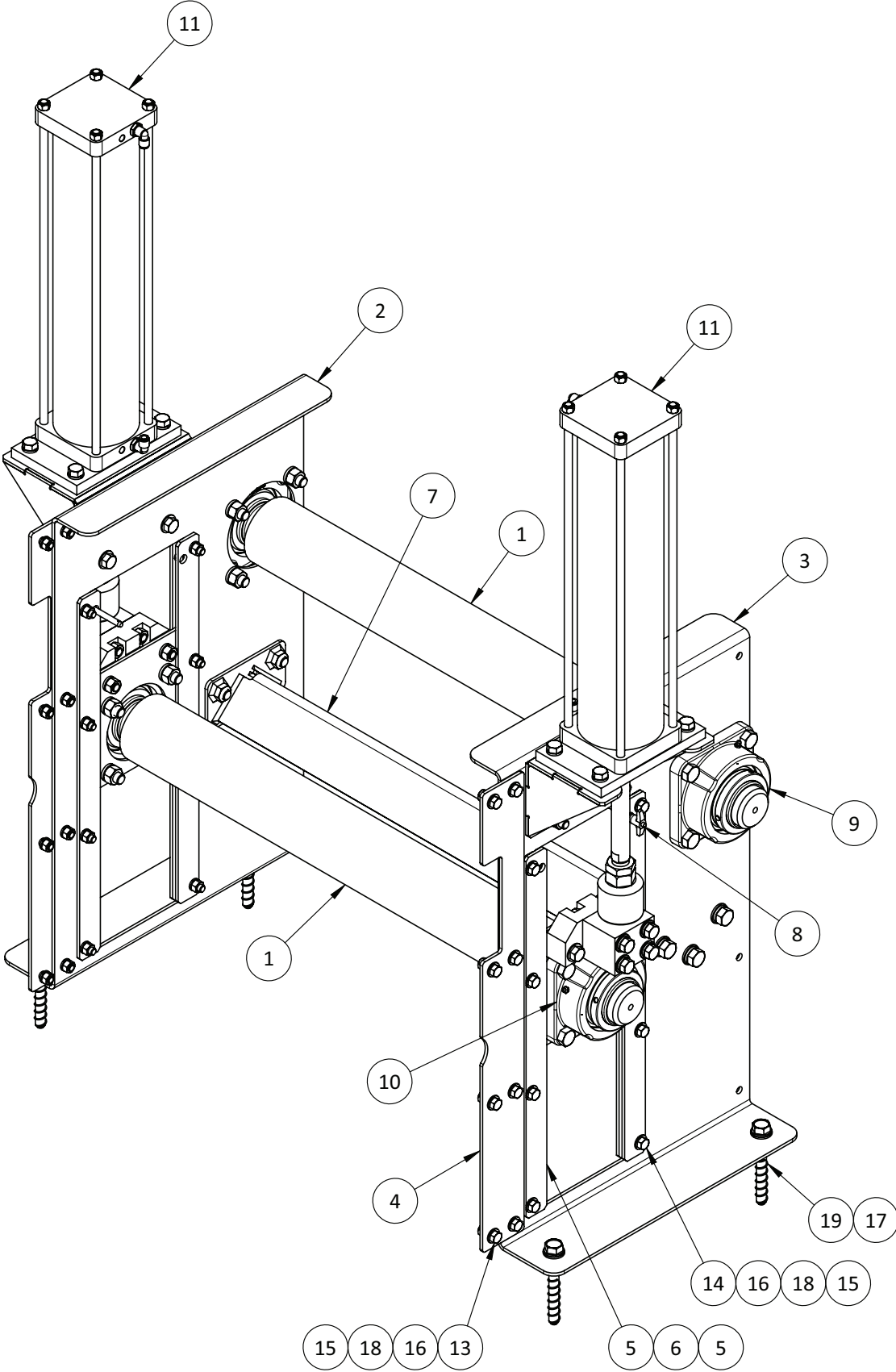

Fixed Bearing Assembly

ITEM NO.	DRAWING NO.	PART NO.	DESCRIPTION	QTY.
1	704 010 25 00	SEE CHART	4-Bolt Flange Bearing, 3-in	1
2		F8-7-27-2-40	3/4-10 x 2-1/2" Hex Bolt, Stainless	4
3		F8-22-27-0-0	3/4-10 Hex Nut, Stainless	4
4		F8-96-27-0-0	3/4" Lock Washer, Stainless	4

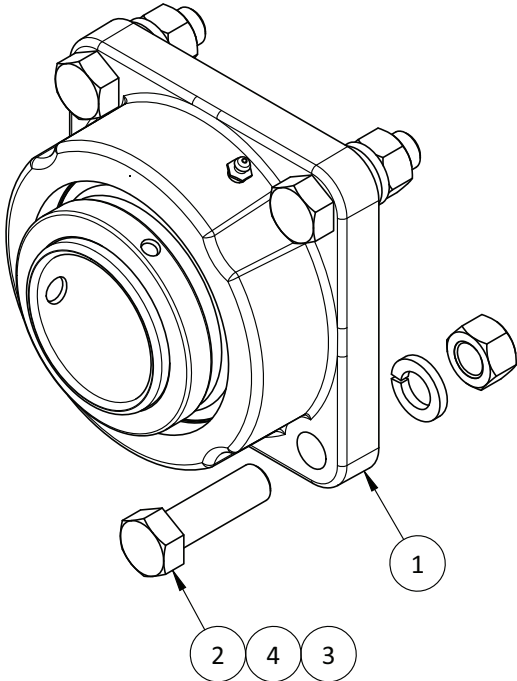

Fixed Bearing Assembly			
Belt Width	Part Number	Drawing Number	Description
24	--	704 510 04 01	Fixed Bearing Assembly
36			
48			

Component Details

Drive Unit Take-up Bearing Assembly

ITEM NO.	DRAWING NO.	PART NO.	DESCRIPTION	QTY.
1	704 010 04 00		Bearing Slide Plate, Take-up	1
2	704 010 25 00	SEE CHART	4-Bolt Flange Bearing, 3-in	1
3		F8-7-27-2-40	3/4-10 x 2-1/2" Hex Bolt, Stainless	4
4		F8-22-27-0-0	3/4-10 Hex Nut, Stainless	4
5		F8-96-27-0-0	3/4" Lock Washer, Stainless	4

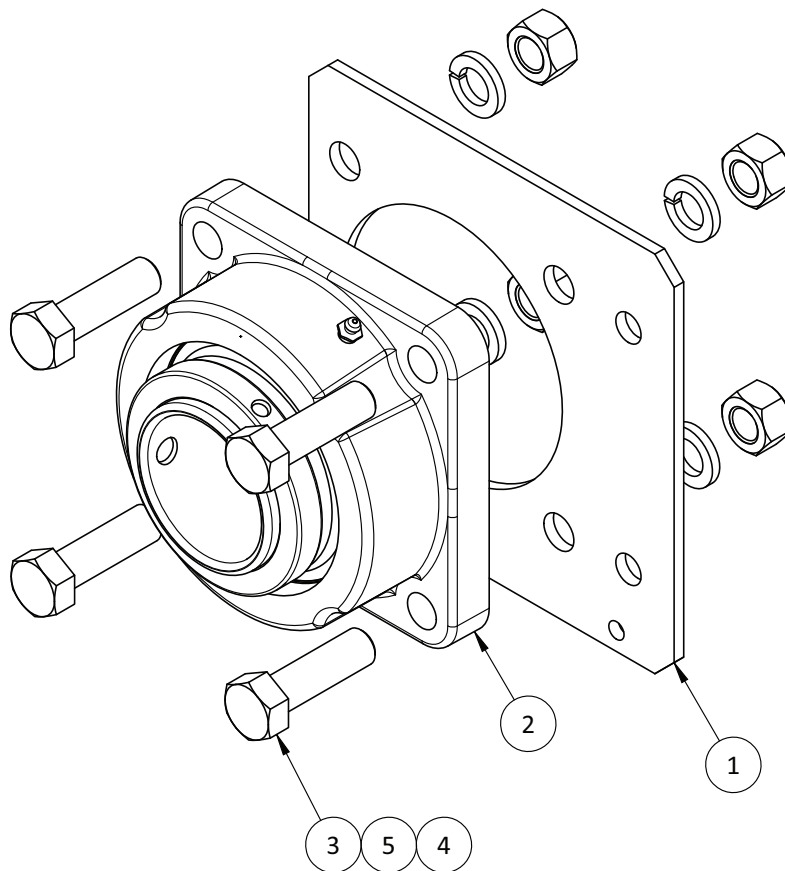

Drive Unit Take-up Bearing Assembly			
Belt Width	Part Number	Drawing Number	Description
24	--	704 510 04 03	Drive Unit Take-up Bearing Assembly
36			
48			

Cylinder Assembly

ITEM NO.	DRAWING NO.	PART NO.	DESCRIPTION	QTY.
1	704 211 01 00		Floating Joint Connecting Bracket	1
2	704 211 02 01		Cylinder Mount Weldment	1
3		CS2F140TN-600	140mm Bore, 600mm Stroke Cylinder	1
4		JAHL80-30-150	Floating Joint	1
5		KQ2L11-37S	1/2" NPT Tube Elbow Fitting	2
6		F8-7-25-2-28	5/8-11 x 1-3/4" Hex Bolt, Stainless	4
7		F8-7-25-2-32	5/8-11 x 2" Hex Bolt, Stainless	4
8		F8-7-25-2-48	5/8-11 x 3" Hex Bolt, Stainless	2
9		F8-7-25-2-80	5/8-11 x 5" Hex Bolt, Stainless	4
10		F8-22-25-0-0	5/8-11 Hex Nut, Stainless	14
11		F8-92-25-0-0	5/8" Flat Washer, Stainless	14
12		F8-96-25-0-0	5/8" Lock Washer, Stainless	14
13		F9-23-70-3-0	M30 x 1.5 Jam Nut, Zinc	1

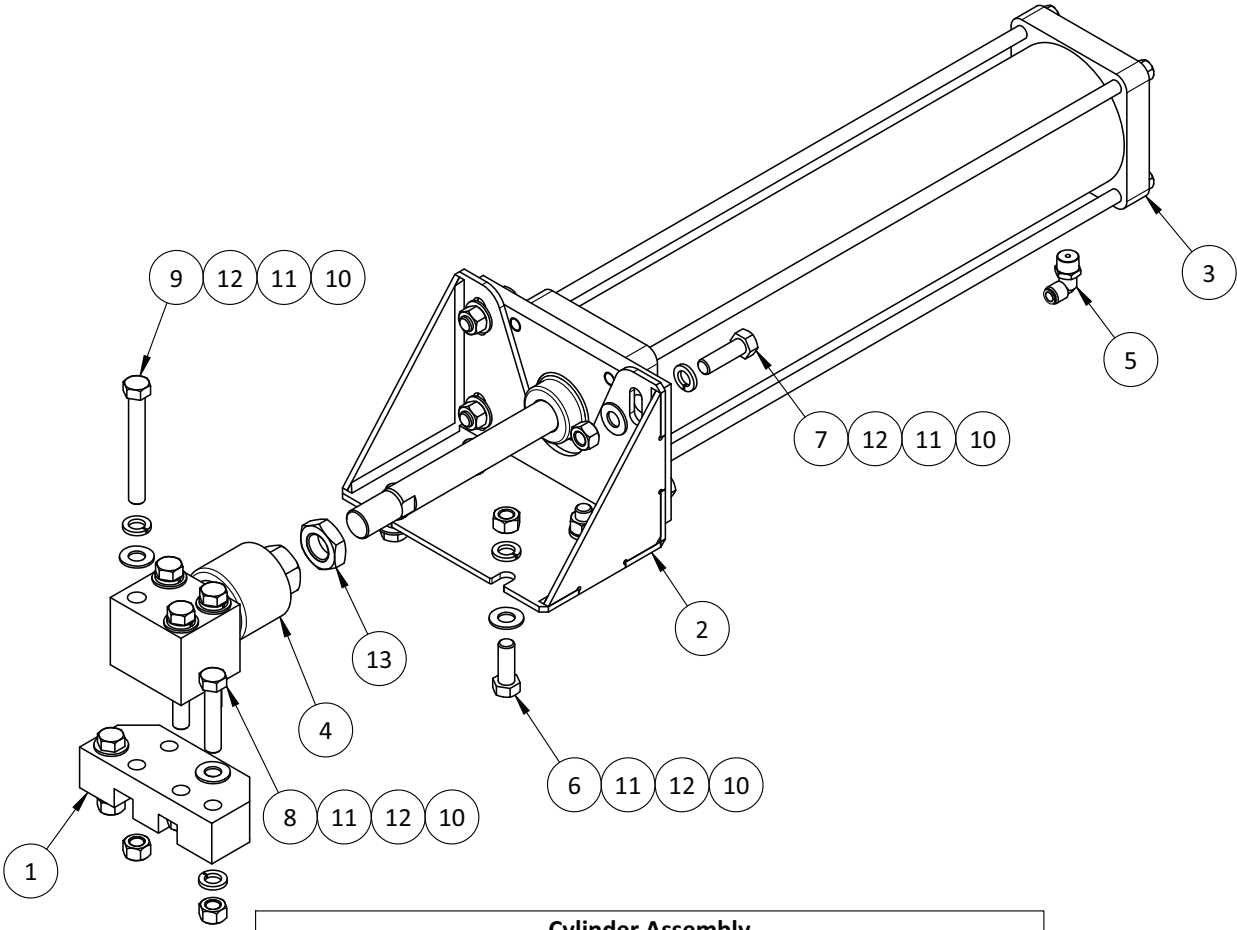

Cylinder Assembly			
Belt Width	Part Number	Drawing Number	Description
24	--	704 511 03 01	Cylinder Assembly
36			
48			

Component Details

Support Weldment Assembly

ITEM NO.	DRAWING NO.	PART NO.	DESCRIPTION	24-in	36-in	48-in
1	702 210 01 00		Support Weldment, 36-in	-	1	-
1	700 210 01 00		Support Weldment, 24-in	1	-	-
1	704 210 01 00		Support Weldment, 48-in	-	-	1
2		F8-7-27-2-28	3/4-10 x 1-3/4" Hex Bolt, Stainless	6	6	6
3		F8-92-27-0-0	3/4" Flat Washer, Stainless	6	6	6
4		F8-96-27-0-0	3/4" Lock Washer, Stainless	6	6	6

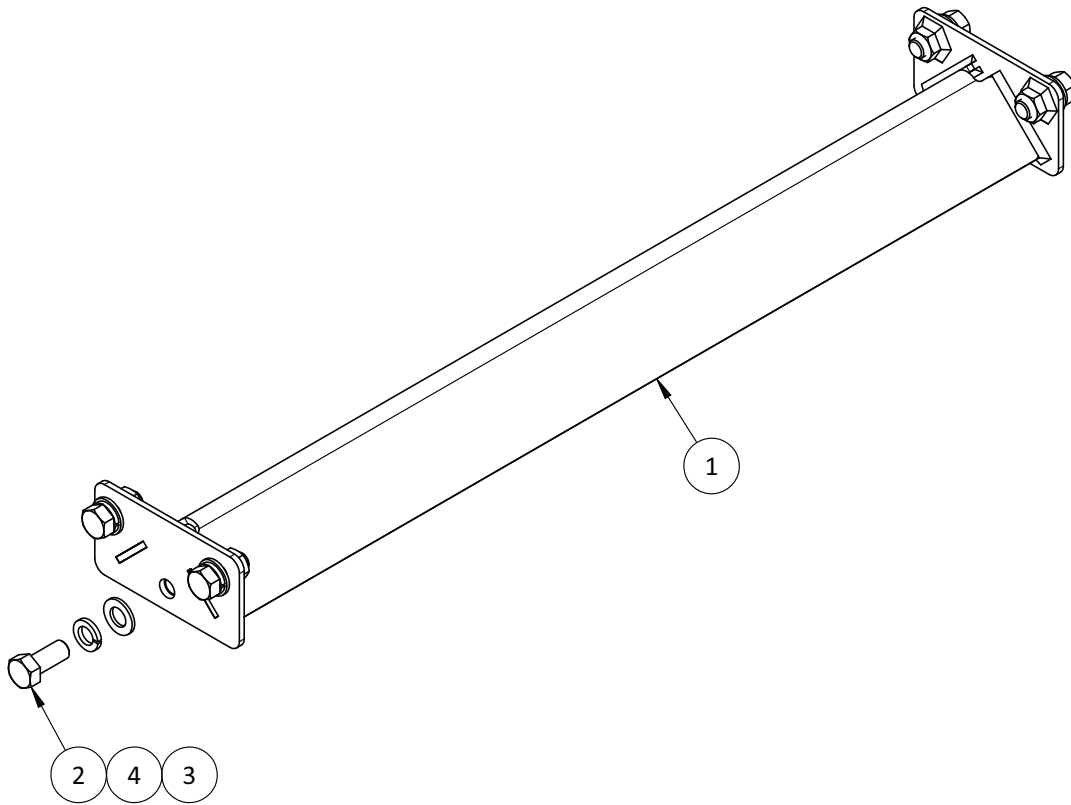

Support Weldment Assembly			
Belt Width	Part Number	Drawing Number	Description
24	--	700 510 05 00	Support Weldment Assembly, 24-in
36	--	702 510 05 00	Support Weldment Assembly, 36-in
48	--	704 510 05 00	Support Weldment Assembly, 48-in

Extruded Diverter Assembly with 60-in Diverter

ITEM NO.	DRAWING NO.	PART NO.	DESCRIPTION	24-in	36-in	48-in
1	702 013 01 00		Vertical Upright 5-1/4-in	4	4	4
2	700 013 02 01		Extruded Bridge 24-in	2	-	-
2	702 013 02 00		Extruded Bridge 36-in	-	2	-
2	704 013 02 00		Extruded Bridge 48-in	-	-	2
3	702 013 03 00		Upright Cap	4	4	4
4	707 070 01 00		Diverter Extrusion 60-in	1	1	1
5		707 070 03 00	Diverter Plate, 60-in	1	1	1
6		F8-29-45-2-0	M5 Nylock Nut, Stainless	8	8	8
7		F8-73-45-2-10	M5 x 16mm SHCS, Stainless	8	8	8
8		F9-7-19-2-96	1/4-20 x 6" Hex Bolt, Zinc	4	4	4
9		F9-29-19-2-0	1/4-20 Nylock Nut, Zinc	4	4	4
10		F9-92-19-0-0	1/4" Washer, Zinc	4	4	4
11		FFB1	Connector	4	4	4
12		FFB6	Connector	10	10	10
13		FFS103	End Cap	2	2	2

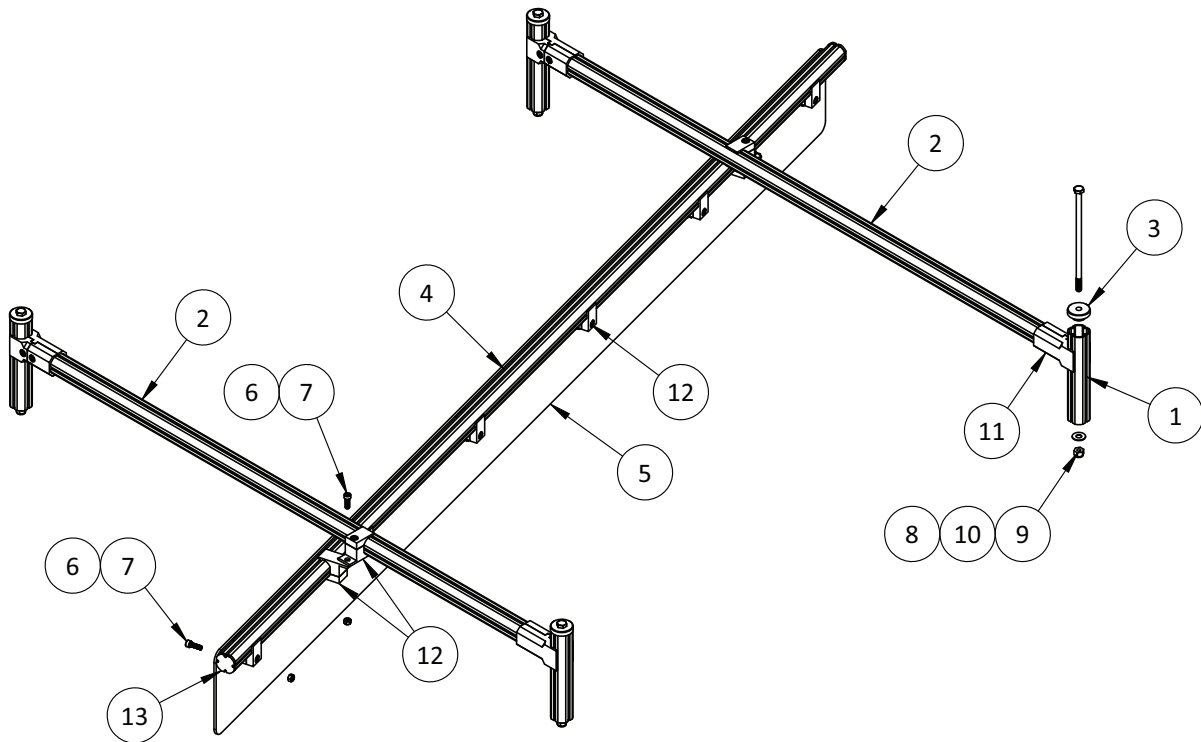

Extruded Diverter Assembly with 60-in Diverter Arm			
Belt Width	Part Number	Drawing Number	Description
24	--	700 130 06 00	Extruded Diverter Assembly with 60-in Diverter 24-in
36	--	702 130 06 00	Extruded Diverter Assembly with 60-in Diverter 36-in
48	--	704 130 06 00	Extruded Diverter Assembly with 60-in Diverter 48-in

SECTION 3 ASSEMBLY & INSTALLATION

Preparing for Installation

Recommended Tool / Equipment List	
Forklift	
Lifting Slings	Lifting lugs are designed for approximately 3/8" chain
6-ft Level	Locating center of belt
Framing Square	Marking center of belt
Speed Square	Marking Connecting Parts
Reciprocating Saw / Hacksaw	Modifying Connecting Part
Hammer Drill / Bit	Anchoring
Tape Measure	Various measurements required
1-in x 2,000-ft Rope	Pulling belt

1. Determine centerline of system.

Note: Centerline must be level to prevent slope in system.

Note: Centerline must be straight to ensure proper tracking of the Belt.

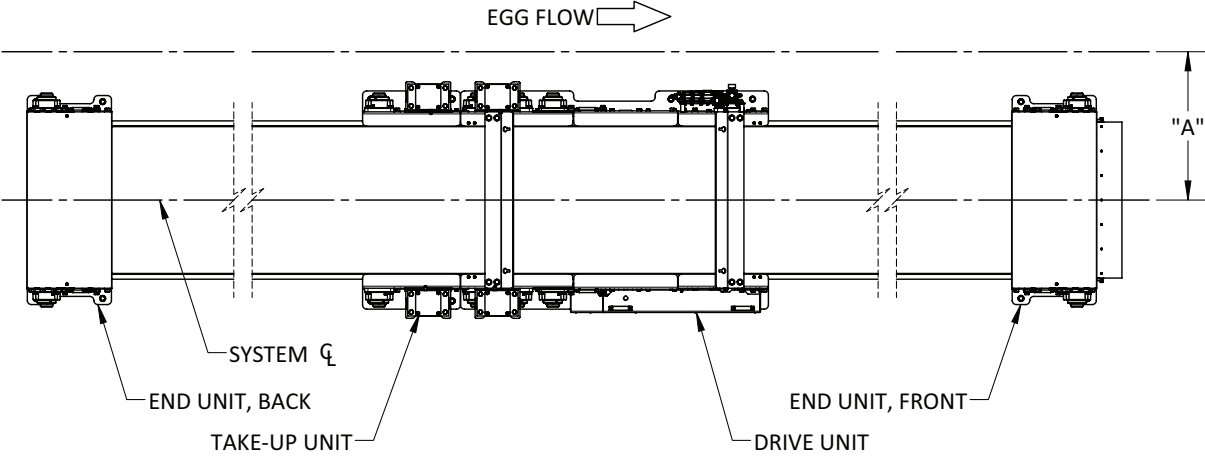

Recommended Clearances from System ζ		
Belt Width	Component	A (inches/mm)
24	Drive Unit/Take-up Unit	78/1981
	End Units/Connecting Parts	30/762
36	Drive Unit/Take-up Unit	84/2134
	End Units/Connecting Parts	36/914
48	Drive Unit/Take-up Unit	90/2286
	End Units/Connecting Parts	42/1067

Installation

- Determine location and height for End Unit, Front.

Note: Custom Support Stand may be required for desired transfer height.

- Determine location and height for Drive Unit.

Note: Drive Unit must be level with End Unit, Front to prevent slope in the system.

Note: Custom Floor Supports may be required.

Note: Do not exceed max recommended distance between Drive Unit and End Unit, Front.

Note: Connecting Parts are intended to be suspended.

Note: If floor supports are required for Connecting Parts, contact your Lubing sales representative.

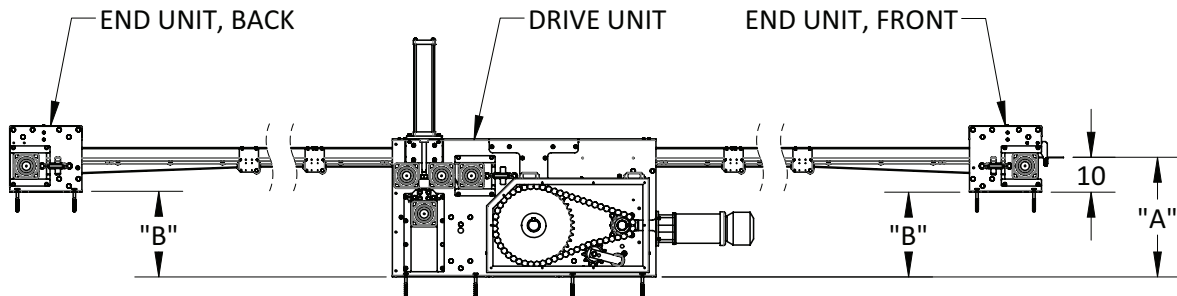

DETERMINE TRANSFER HEIGHT "A" AT THE END UNIT, FRONT

$A - 10" = \text{END UNIT SUPPORT STAND HEIGHT "B"}$

IF "B" IS HIGHER THAN 24", DRIVE UNIT FLOOR SUPPORTS WILL BE REQUIRED

$B - 24" = \text{DRIVE UNIT FLOOR SUPPORT HEIGHT}$

CALCULATIONS ASSUME LEVEL FLOOR AND CONSISTENT ELEVATION, IF FLOOR ELEVATION CHANGES AT THE LOCATION OF THE COMPONENTS ABOVE, ADDITIONAL HEIGHT MAY BE REQUIRED

FLOOR SUPPORT/SUPPORT STAND CONSTRUCTION
MAY DIFFER BASED ON TOTAL HEIGHTS REQUIRED



Support Stands and Floor Supports are special order and not included with system orders.

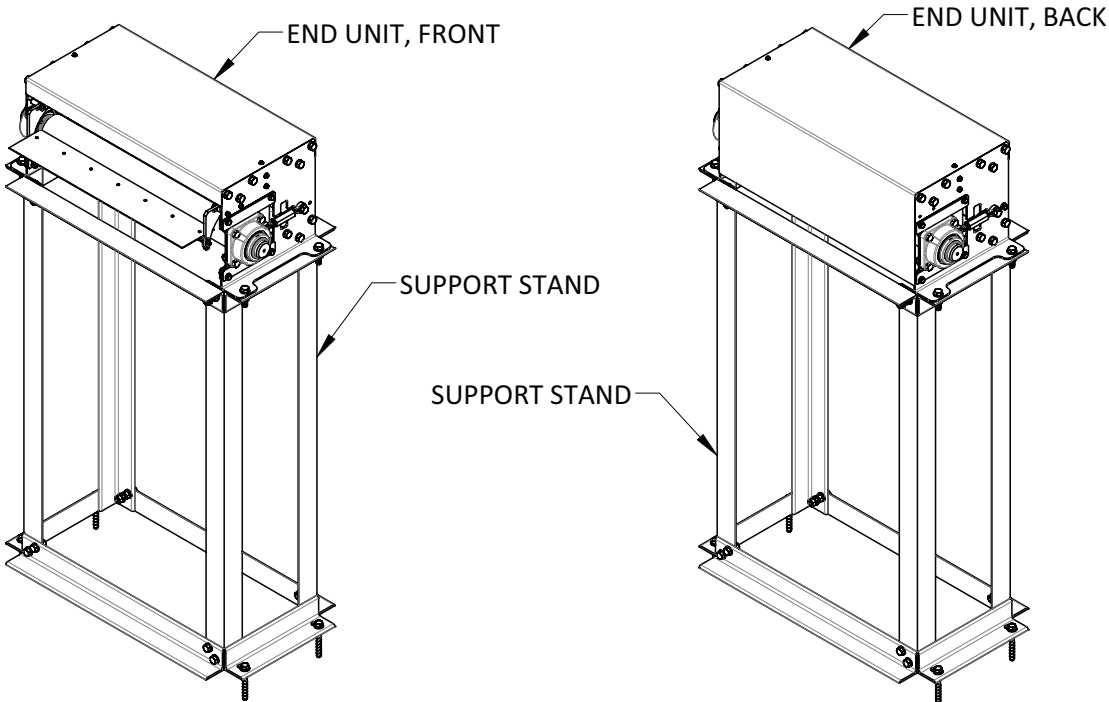
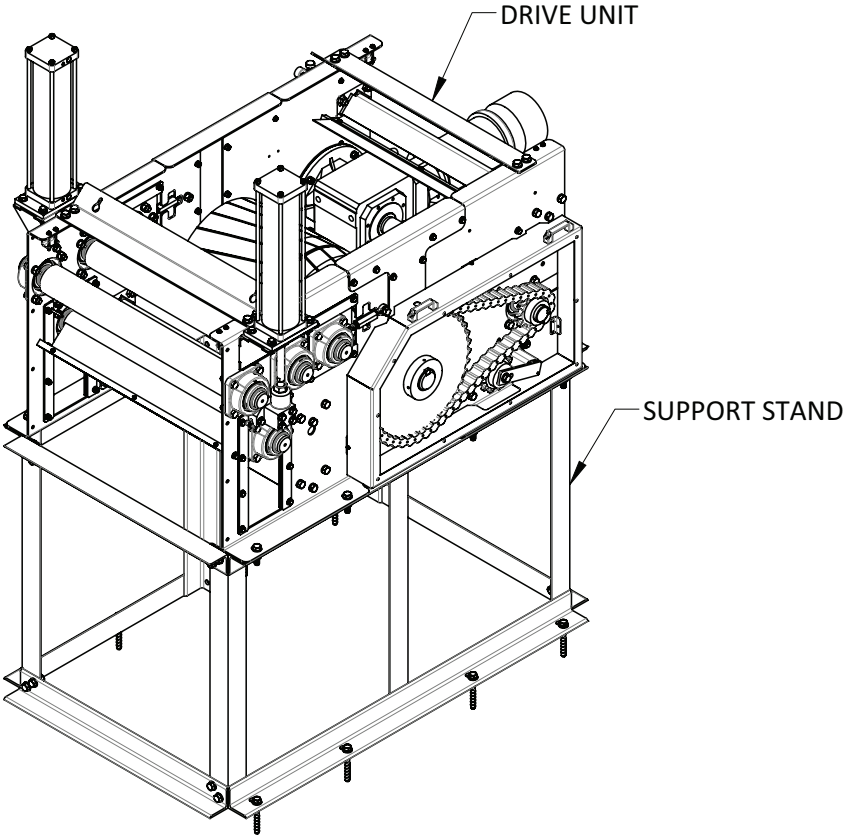

Installation

4. Position and anchor End Unit, Front.

Note: If a Support Stand is required, attach to End Unit, Front prior to anchoring.

Note: If a Support Stand was purchased through Lubing Systems, use supplied hardware for attaching End Unit, Front.



End Unit, Front must be aligned to centerline and level to ensure proper operation.

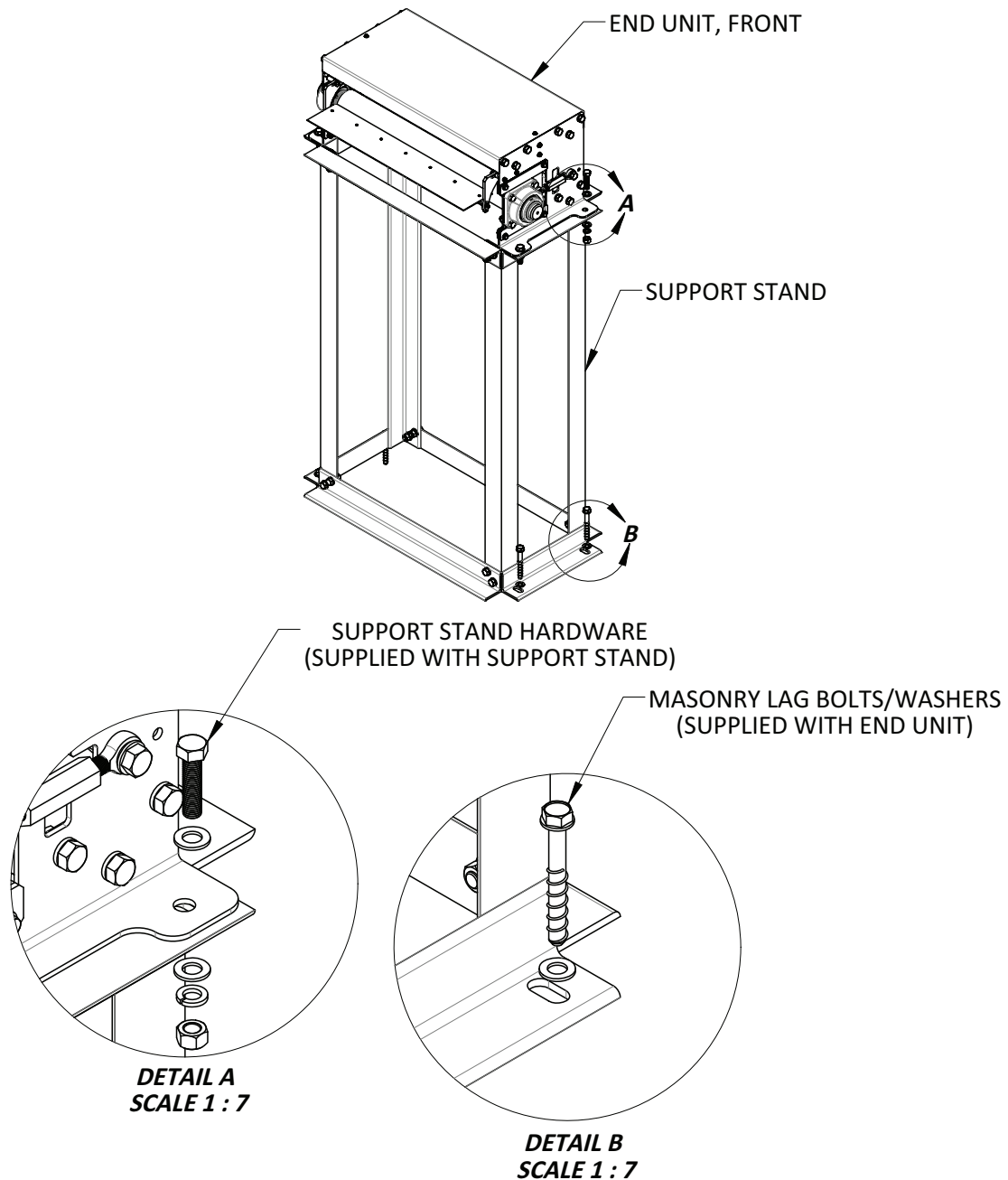

5. Position and anchor Drive Unit

Note: If Floor Supports are required, attach to Drive Unit prior to anchoring.

Note: If Floor Supports were purchased through Lubing Systems, use supplied hardware for attaching Drive Unit.

Note: Do not exceed the maximum recommended distance from End Unit, Front.



Drive Unit must be aligned to centerline and level to ensure proper operation.
All guards should be in place before operating system.

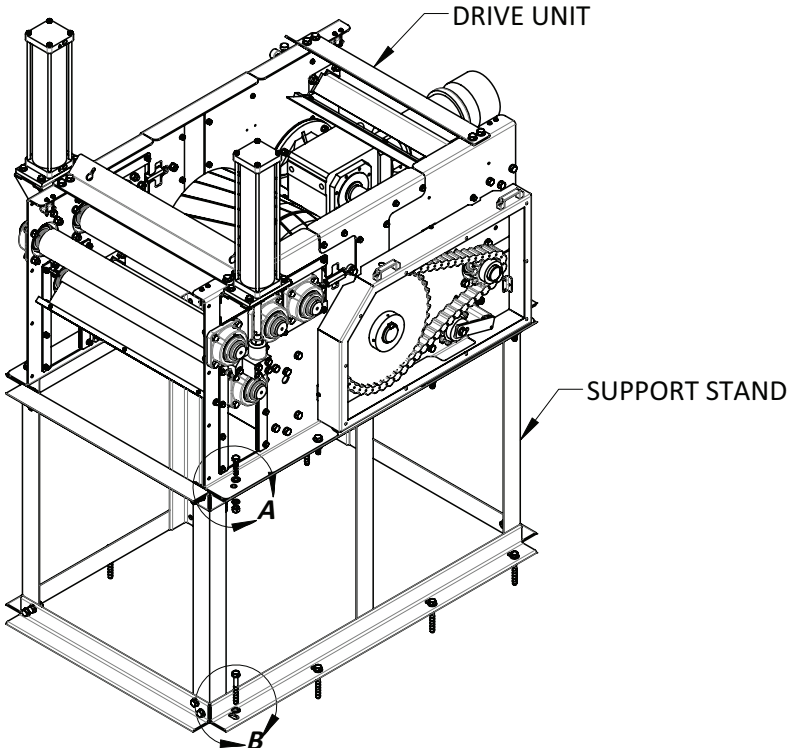

FLOOR SUPPORT HARDWARE
(SUPPLIED WITH SUPPORT STAND)

MASONRY ANCHOR BOLTS/WASHERS
(SUPPLIED WITH DRIVE UNIT)

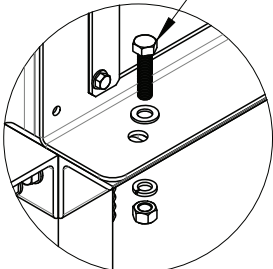

DETAIL A
SCALE 1 : 10

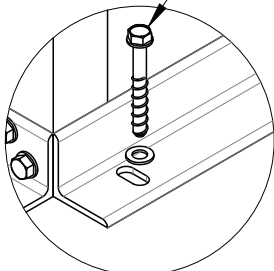

DETAIL B
SCALE 1 : 10

Installation

6. Attach Connecting Plates and Bottom Rollers to all Connecting Parts.

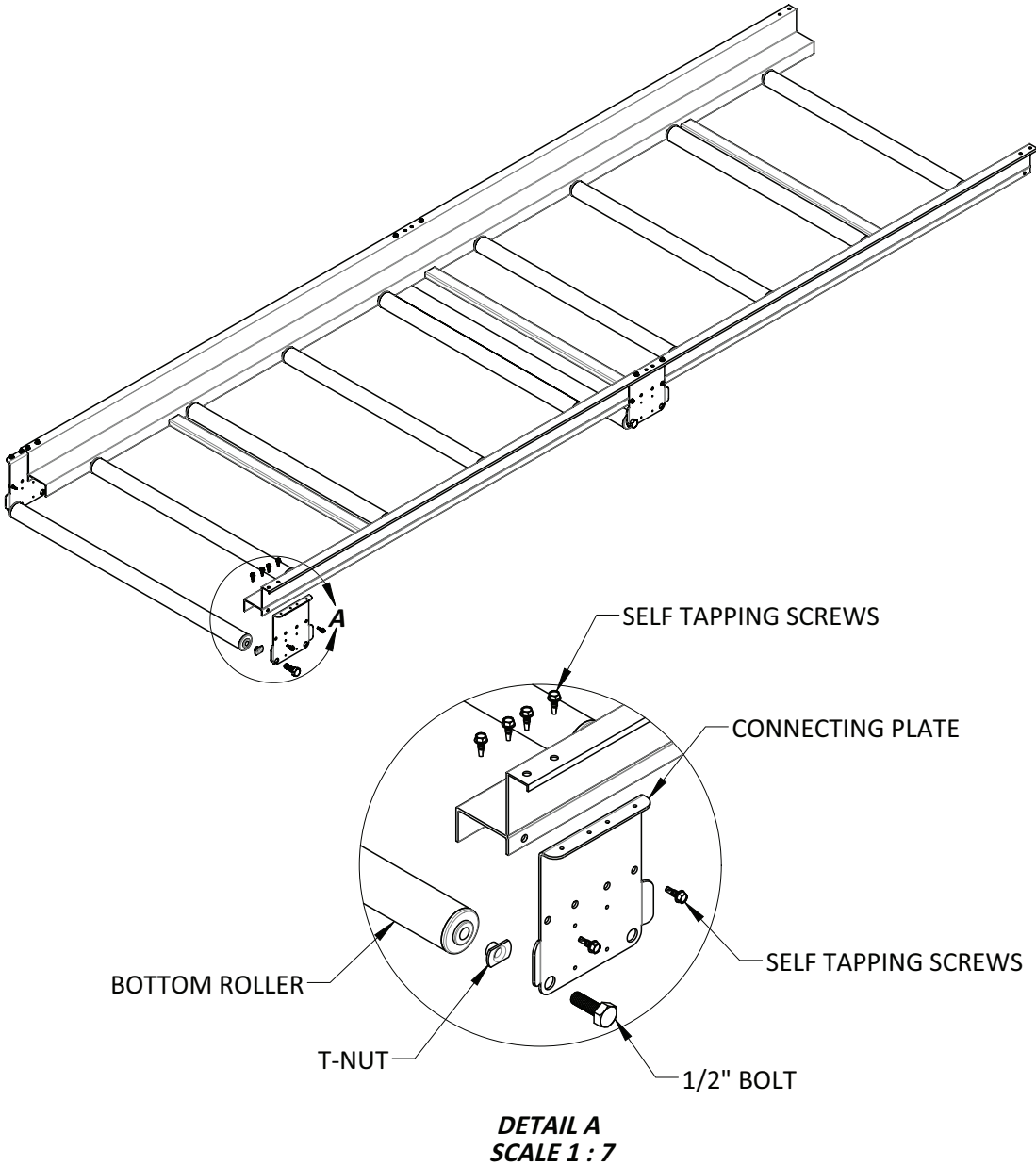

7. Attach Connecting Part to End Unit, Front using supplied hardware.

 End of Connecting Part should be flush with mounting bracket to avoid contact with roller.

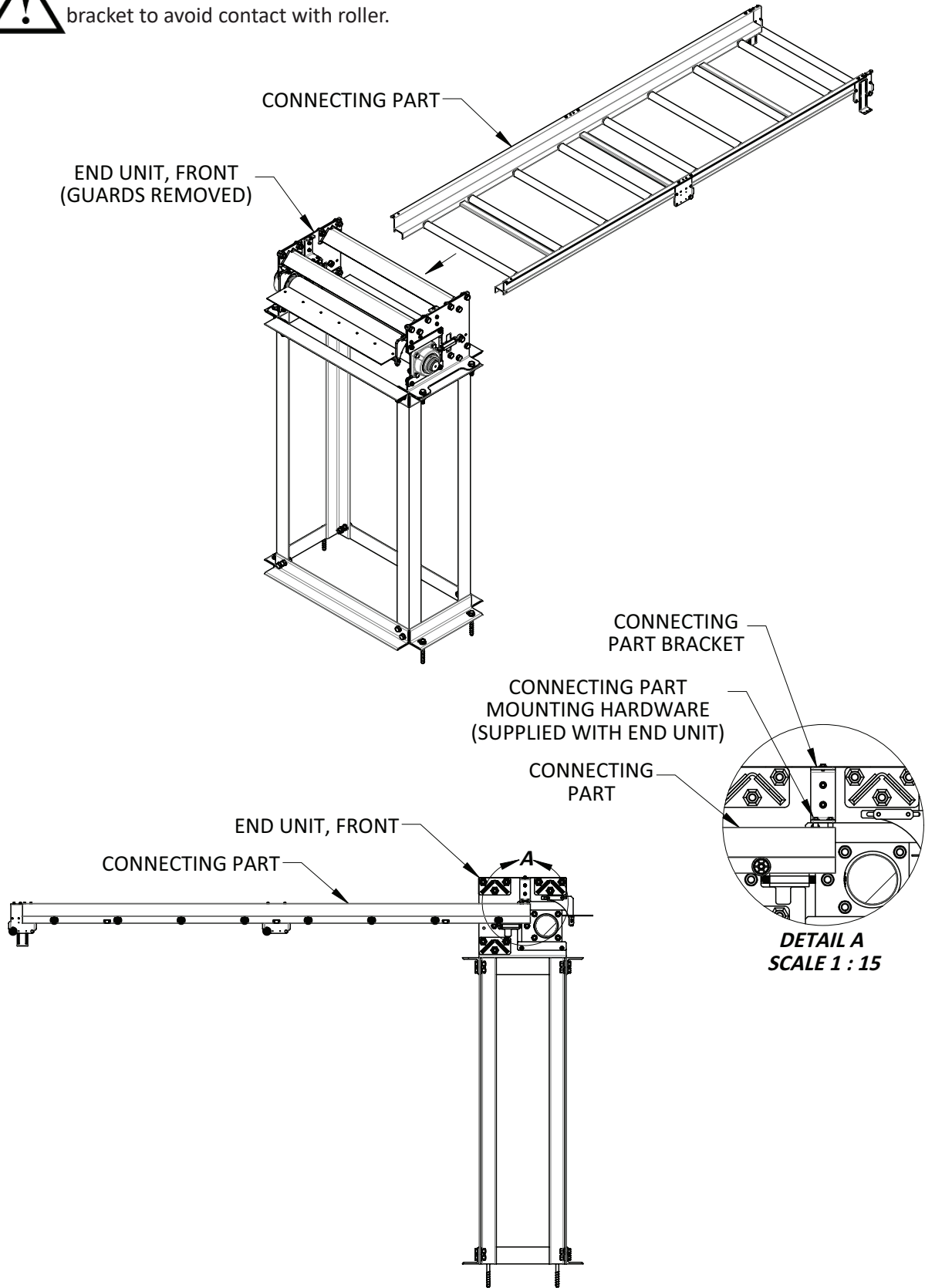

Installation



All guards must be in place before operating system.

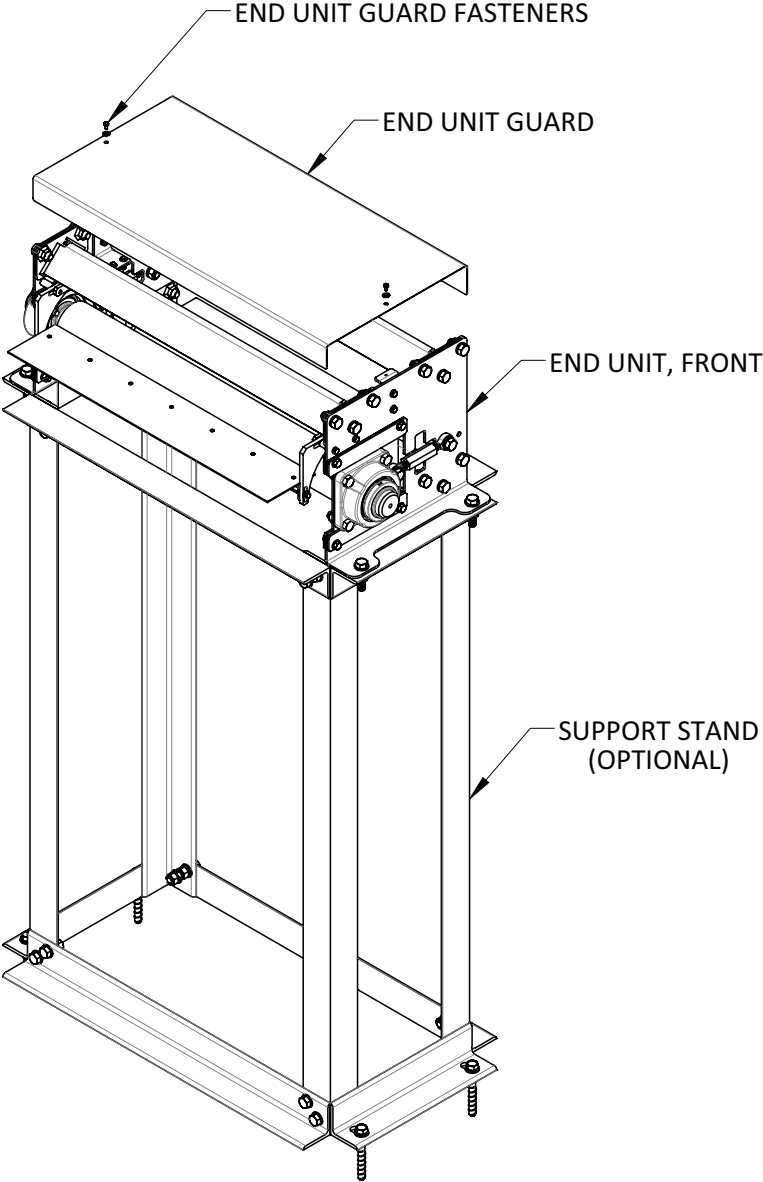

8. Continue to attach Connecting Parts up to Drive Unit using supplied hardware and Connecting Plates.

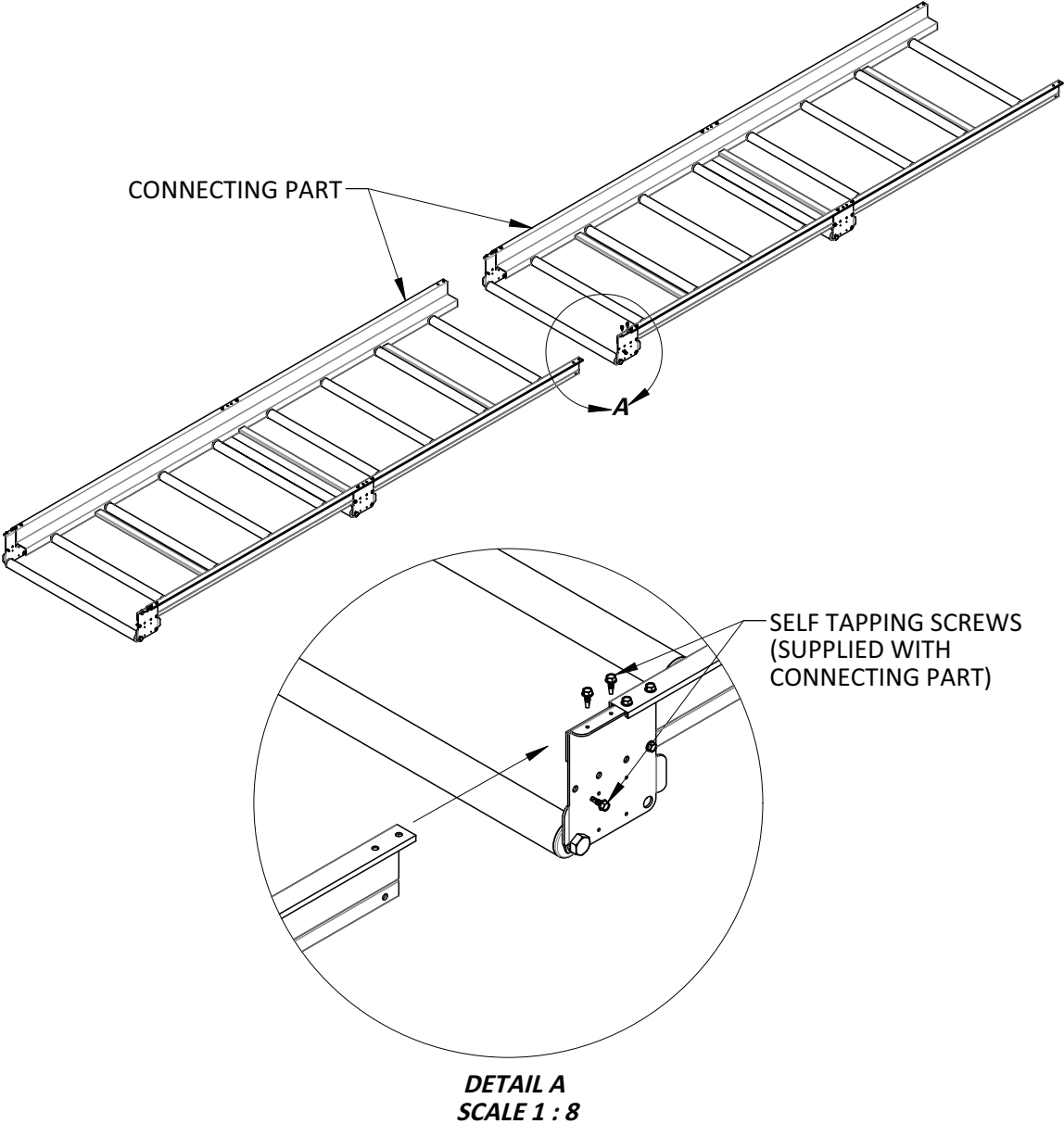

Installation

9. Attach Connecting Part to Drive Unit using supplied hardware and Connecting Brackets.
10. Determine the location of the Connecting Part within the Drive Unit. Verify the Connecting Part is aligned and centered through the Drive Unit and transfer the 5/16" mounting hole pattern from the Drive Unit onto the Connecting Part Sidesheet on both sides.
11. Attach the Connecting Part using supplied hardware and brackets.



All guards must be in place before operating system.

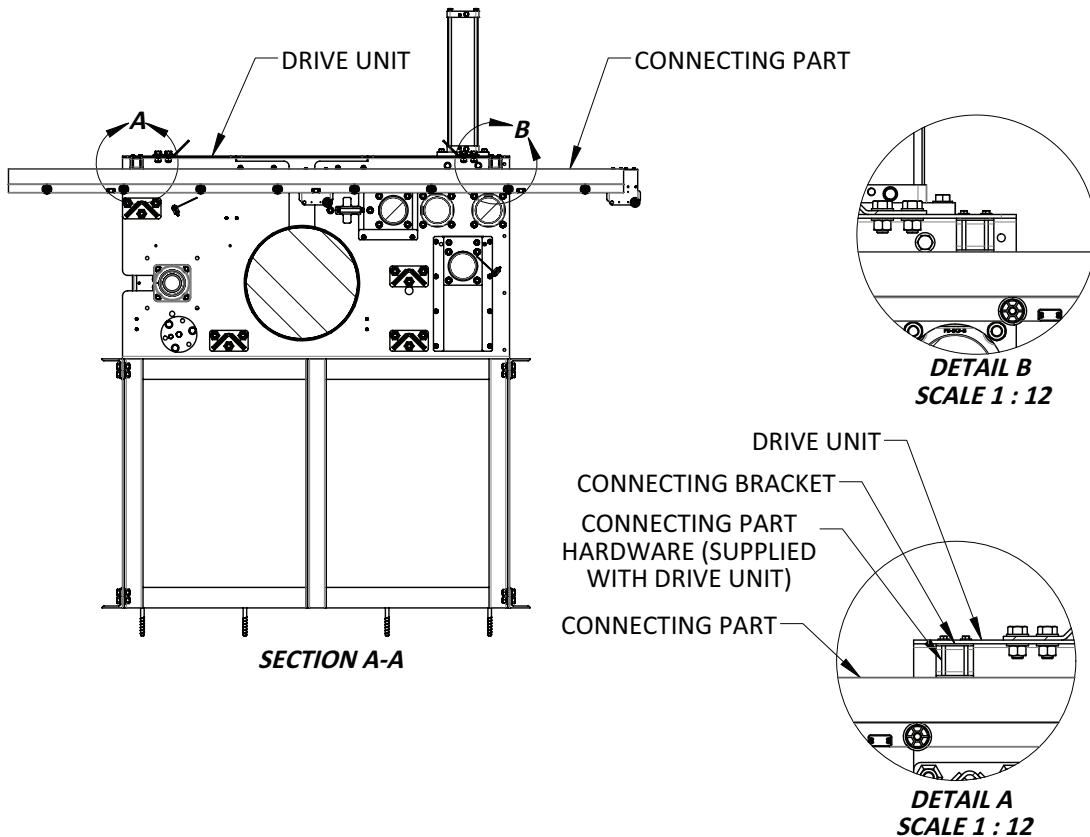
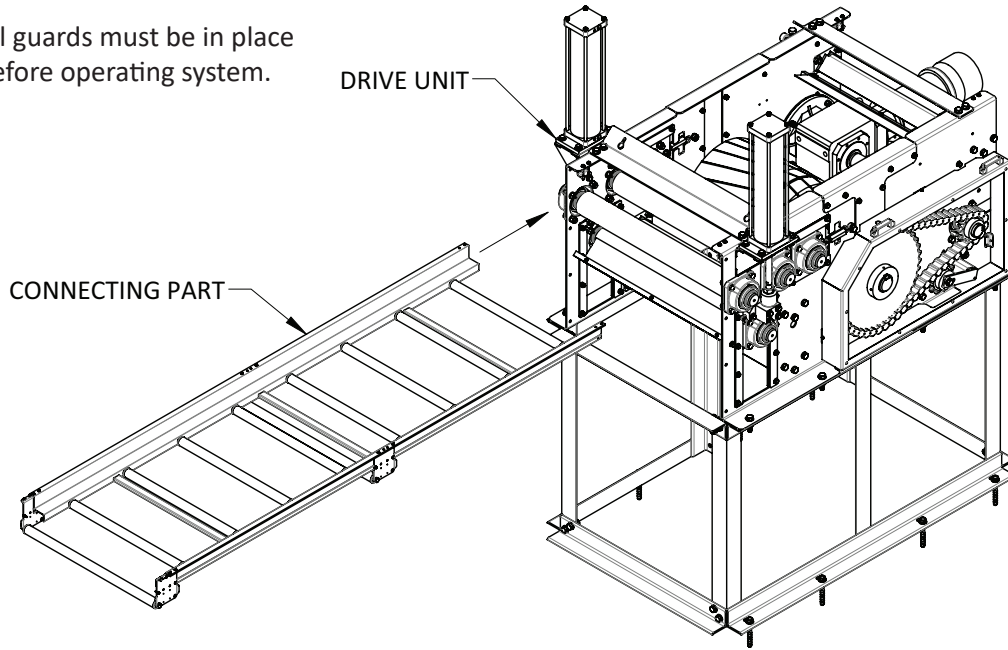

12. Position and anchor End Unit, Back.

Note: If Support Stand is required, attach to End Unit, Back prior to anchoring.

Note: If Support Stand was purchased through Lubing Systems, use supplied hardware for attaching End Unit, Back.



End Unit, Back must be aligned to centerline and level to ensure proper operation.
If anchoring End Unit, Back to surface other than concrete, use appropriate fasteners.

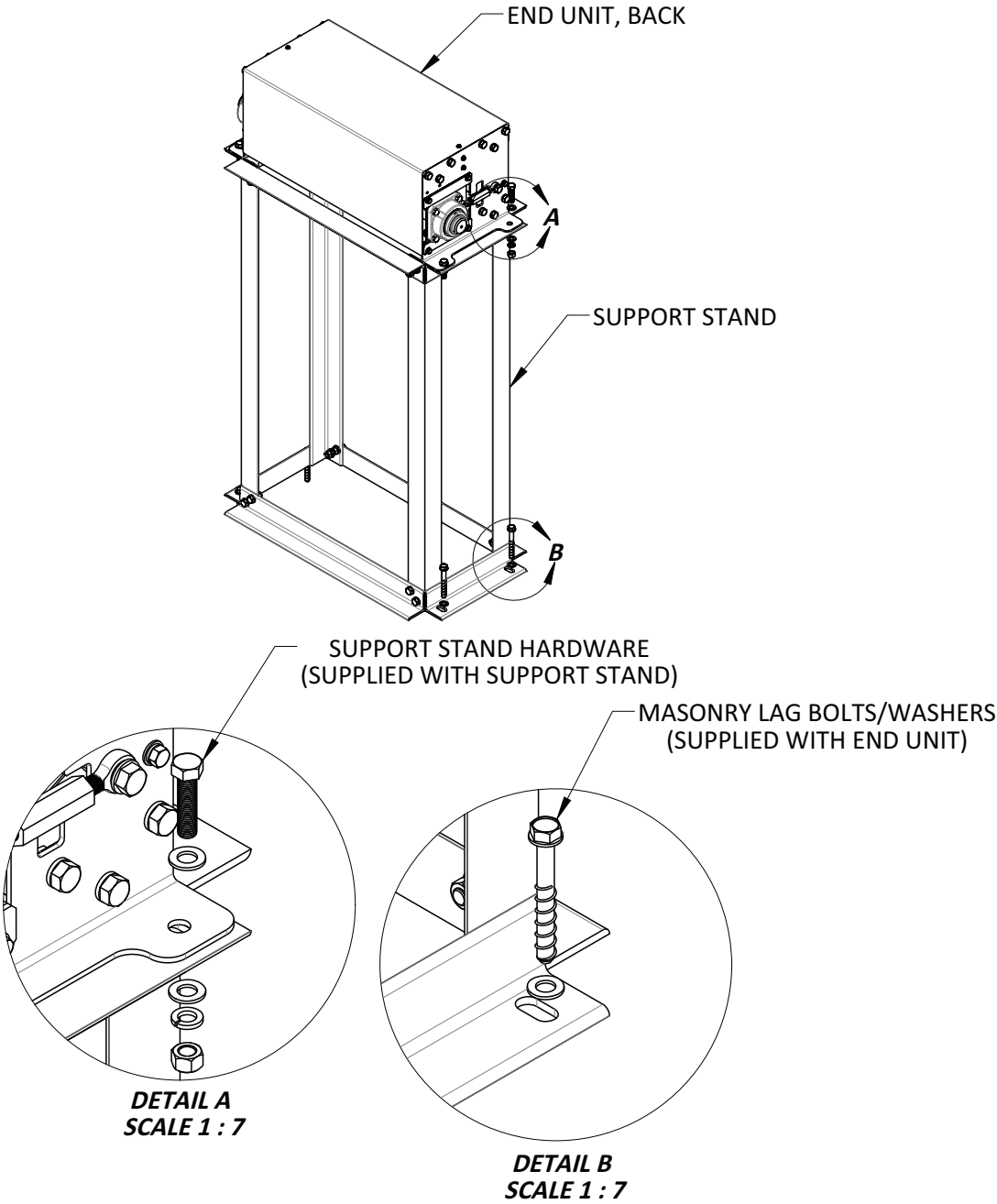

Installation

13. Continue to attach Connecting Parts up to End Unit, Back.

14. If needed, modify length of Connecting Part and add hole pattern shown below.



Both Sidesheets must be cut to the same length to ensure proper operation.

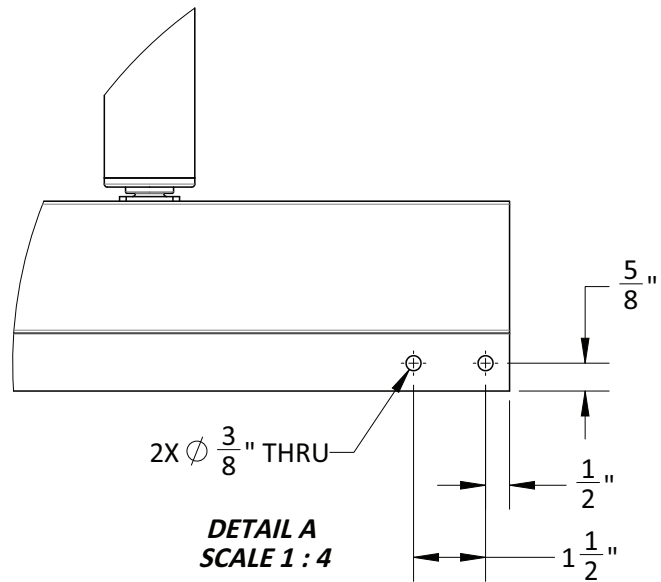
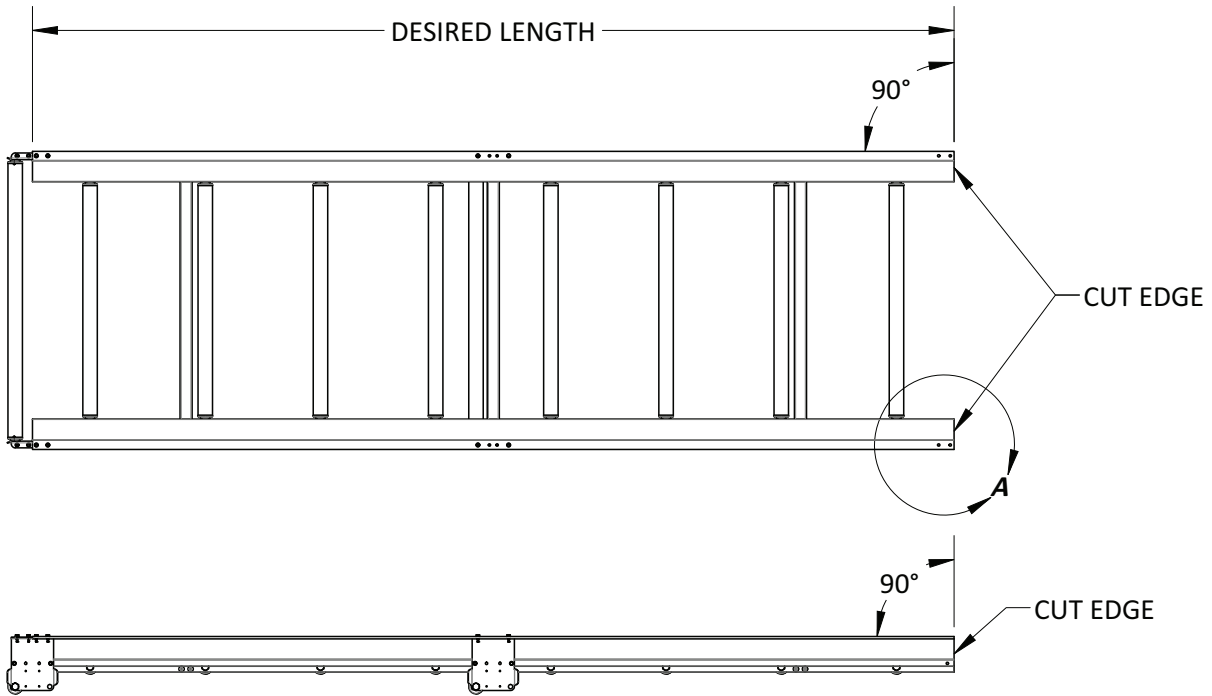

15. Attach Connecting Part to End Unit, Back using supplied hardware.



End of Connecting Part should be flush with mounting bracket to avoid contact with roller.

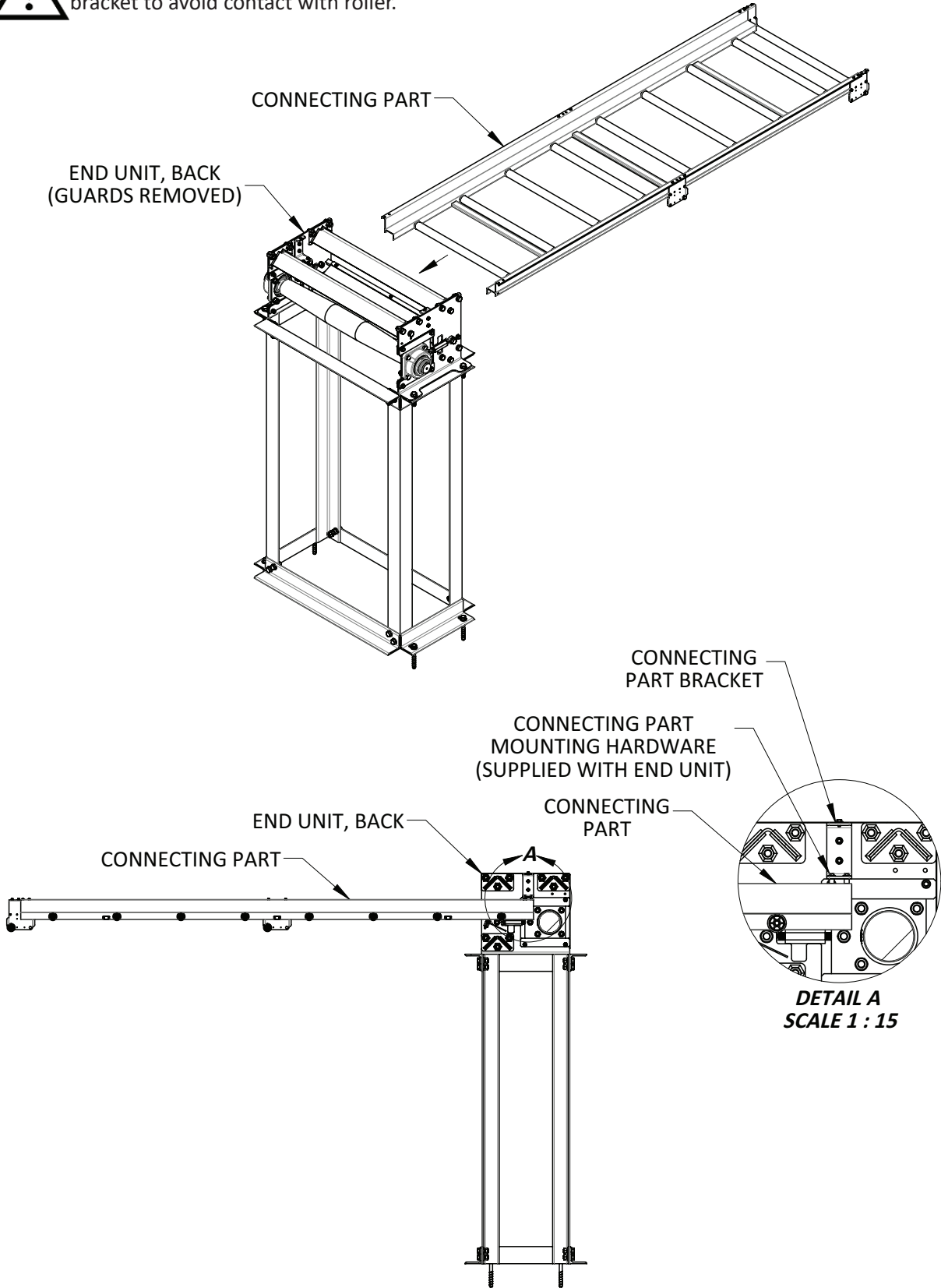

Installation



All guards must be in place before operating system.

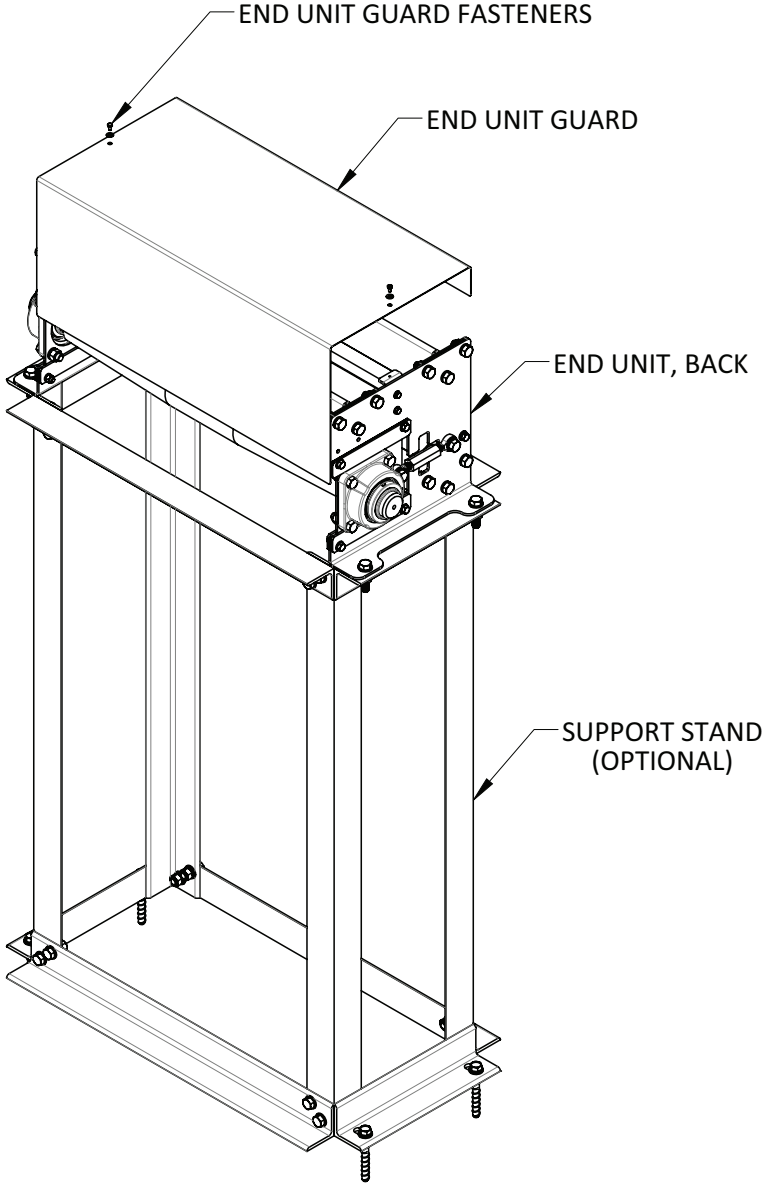

16. After installation, cut Connecting Part Sidesheet at desired location for egg collectors.

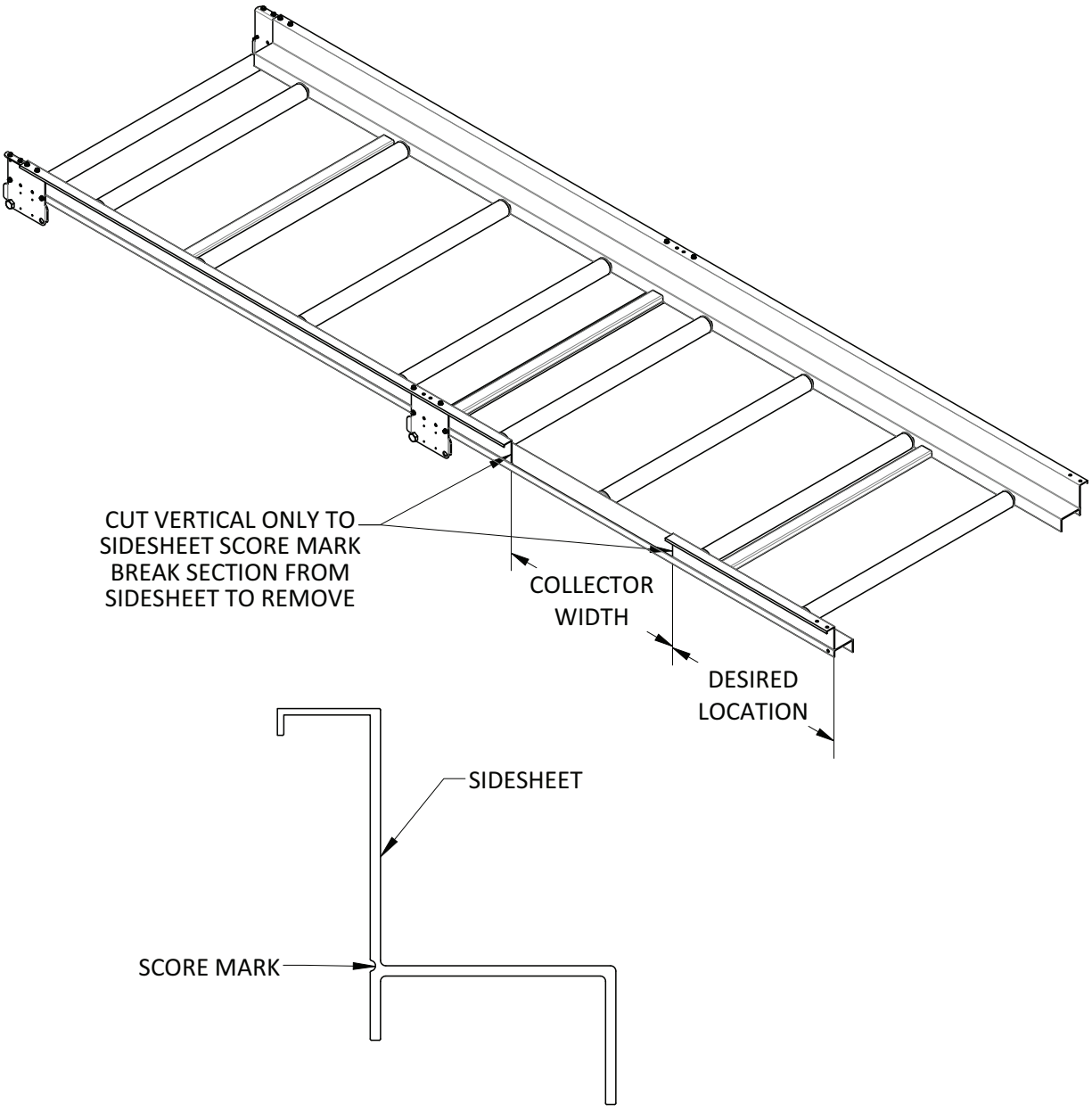

Pneumatic Setup

- 17. Customer must supply and install shut-off valve prior to Pneumatic Panel.
- 18. Attach Take-up Cylinder Mount Bracket to Drive Unit Sidesheet using supplied hardware. Attach Floating Joint Mount Plate to the Take-up Bearing Plate using supplied hardware.

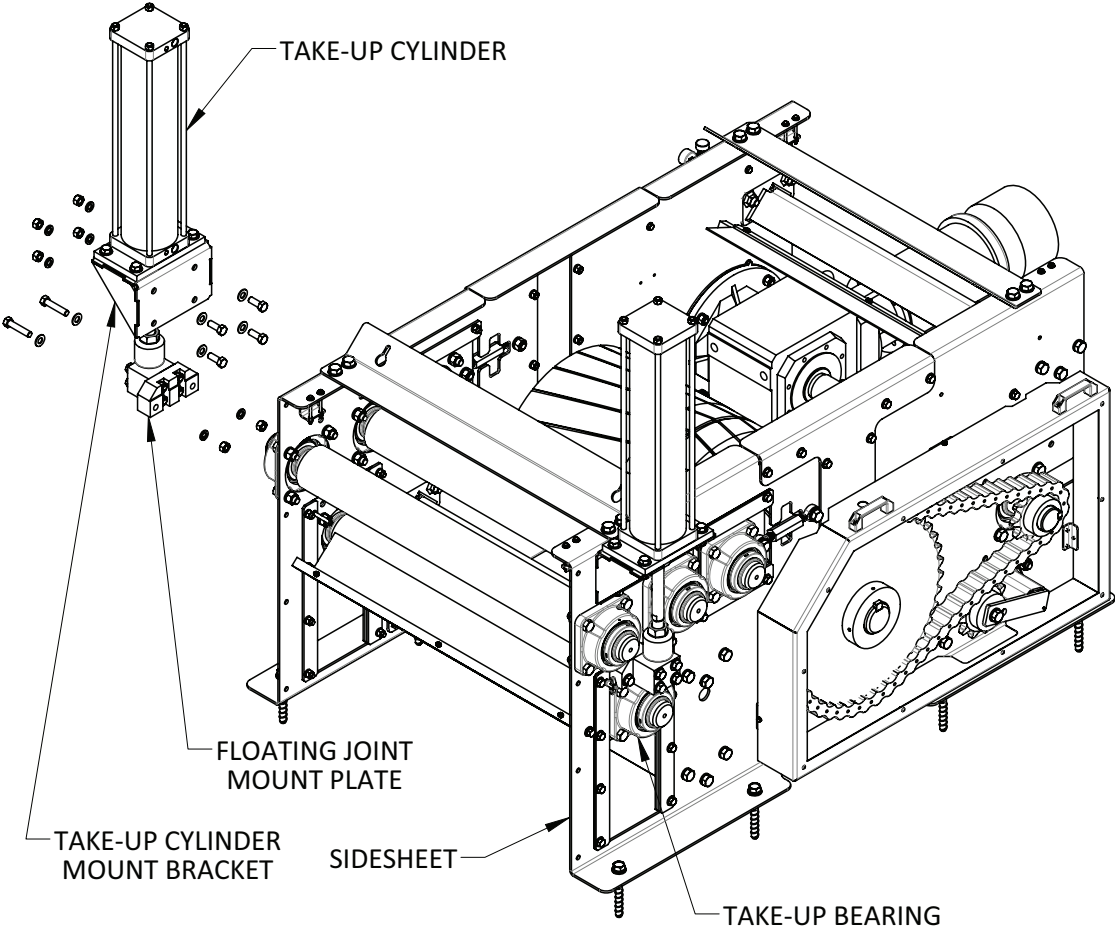

19. Plumb Air Cylinders using supplied 3/8" pneumatic tubing.

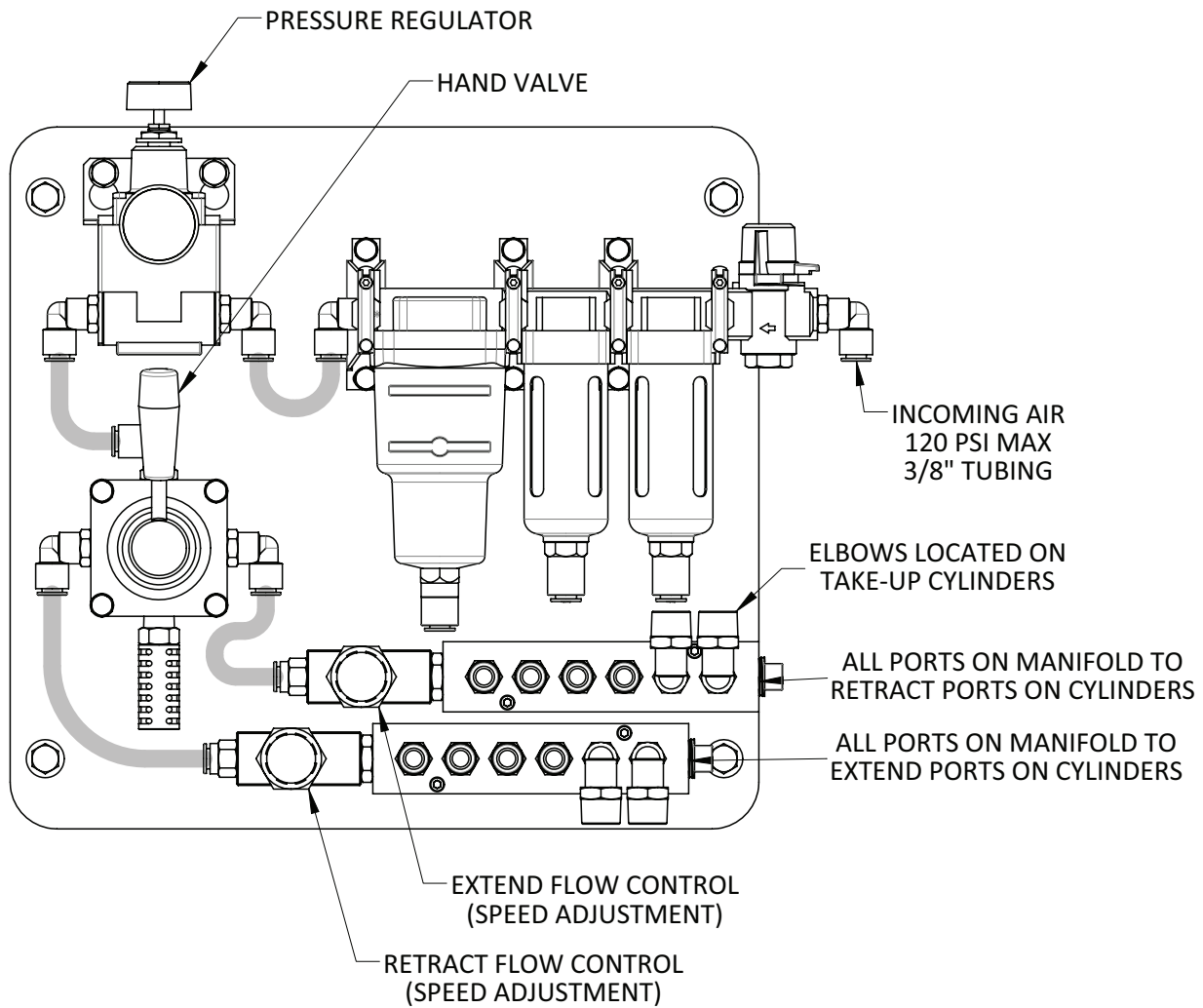

*ALL TUBING LENGTHS FROM PNEUMATIC PANEL (SHOWN ABOVE) TO AIR CYLINDERS MUST BE THE SAME LENGTH TO ENSURE REACTION SPEEDS ON BOTH SIDES ARE SYNCHRONOUS

NOTE: IF MODULAR TAKE-UP UNIT IS BEING INSTALLED REMOVE PLUGS FROM NECESSARY PORTS ON MANIFOLDS AND PLUMB TO CYLINDERS ACCORDINGLY

Installation

20. The Hand Valve controls the operation of the Take-Up Assembly.



Safety Pins must be in place on both sides before beginning maintenance on system. If incoming air pressure is lost, the Take-Up Assembly will move to a relaxed state.

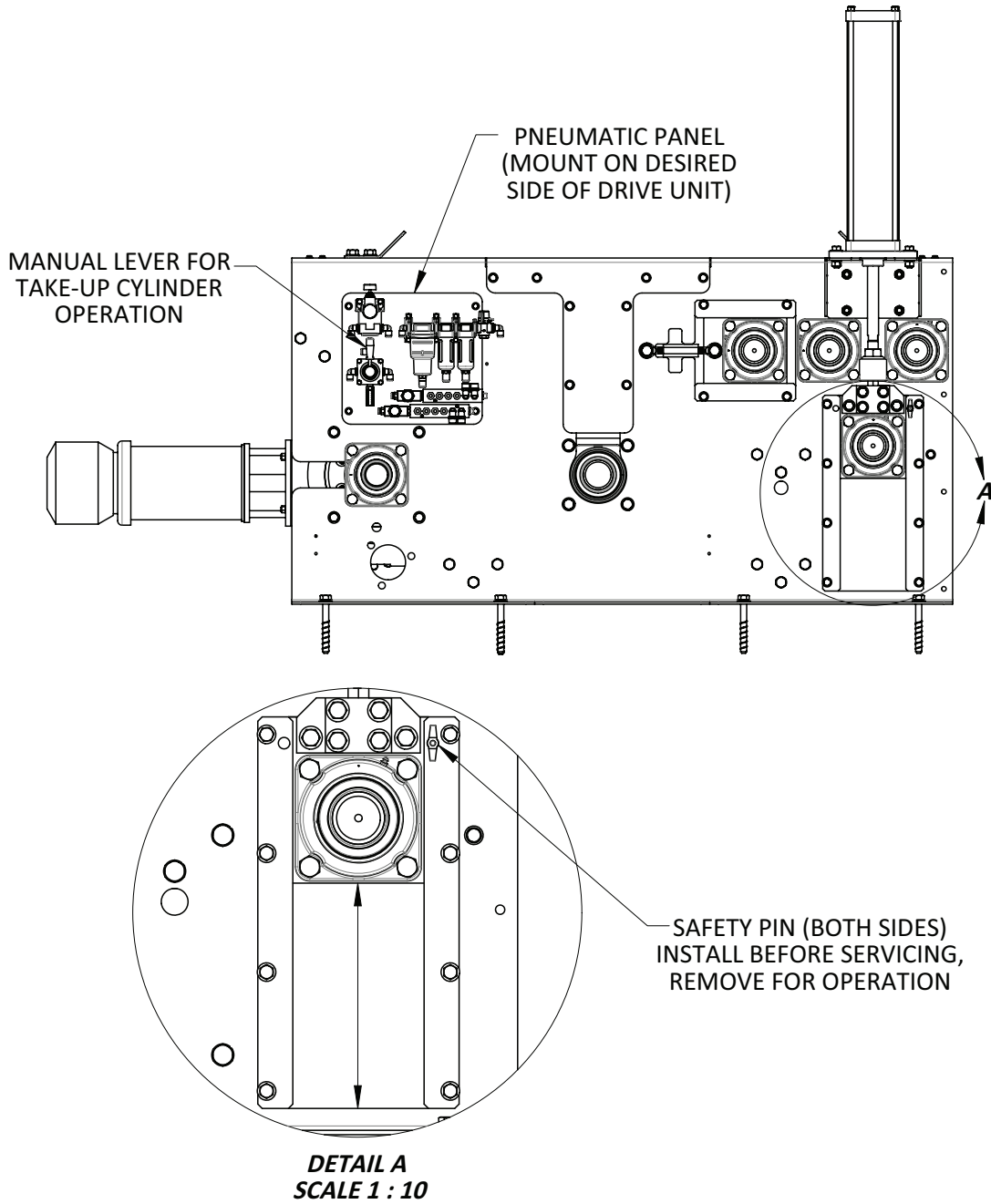

Belt Threading

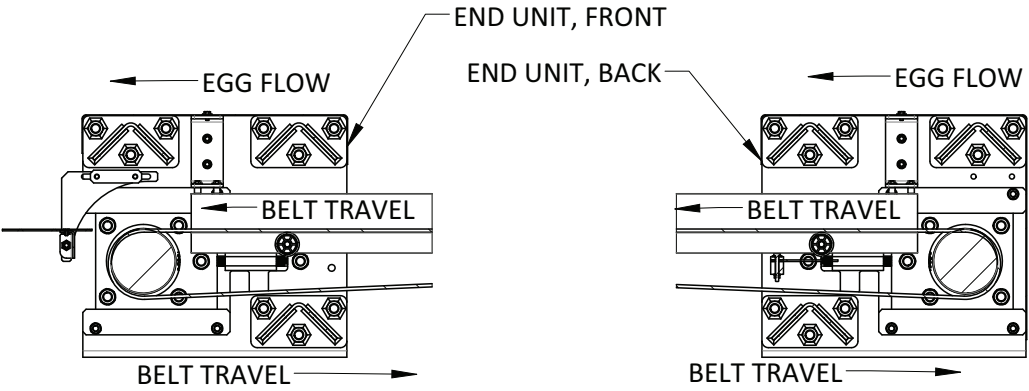
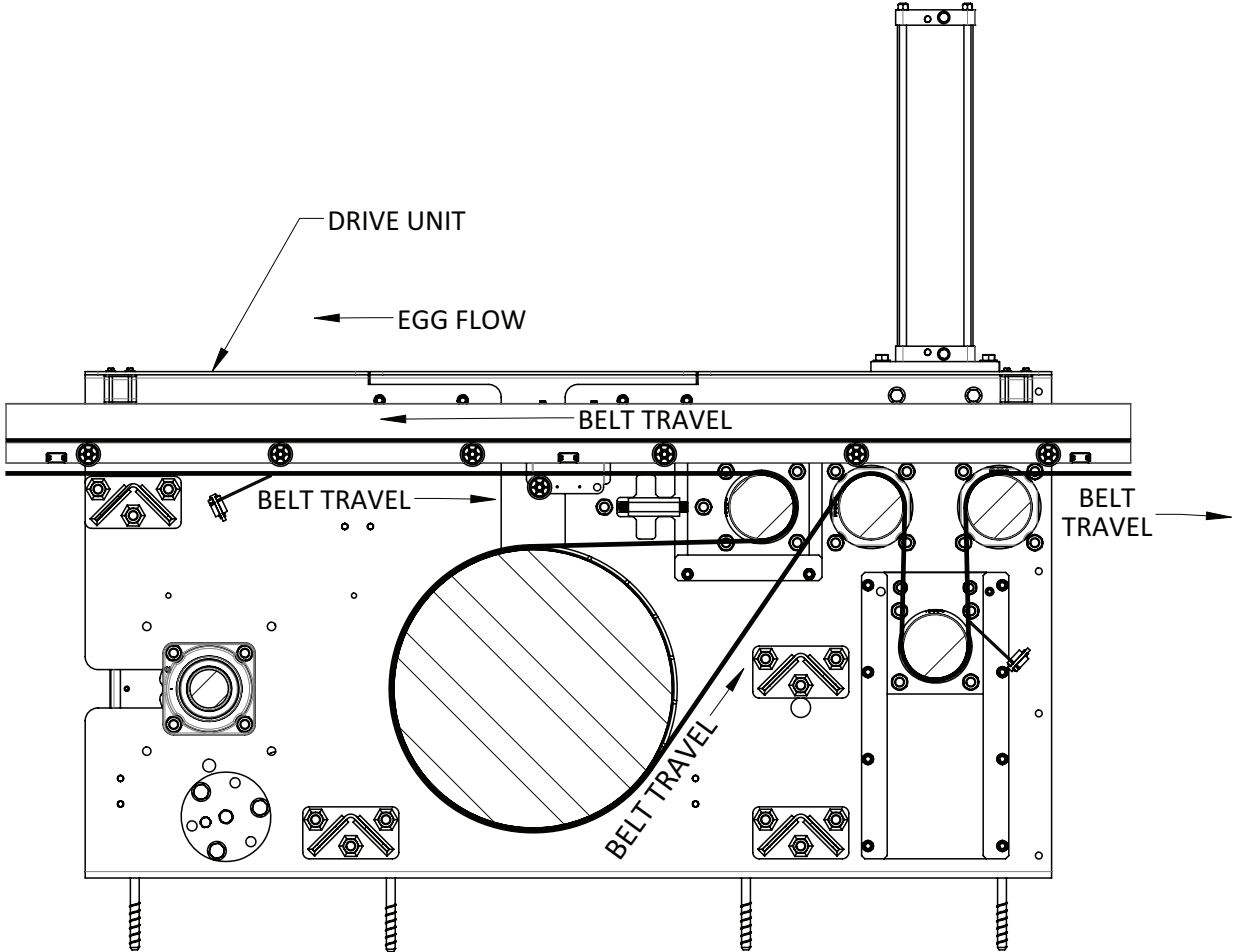

Installation

Belt Threading Modular Take-Up (Optional)

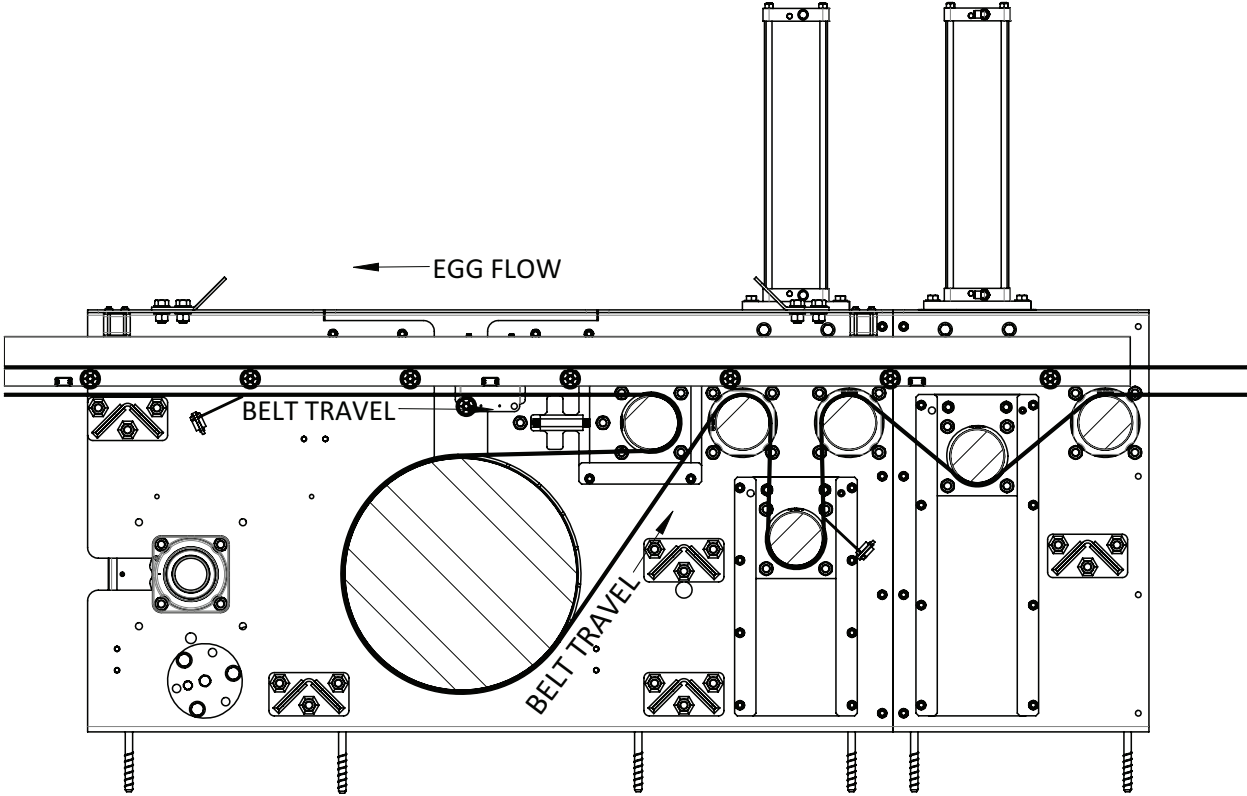

Belt Installation

- 21. Take-up Cylinders must be in the upmost position with Safety Pins in place before threading Belt. This will allow maximum take-up after the Belt installation is complete. If air pressure is applied, use the Hand Valve to move the Take-up Cylinders to the appropriate position.



Failure to observe will result in slippage between Belt and Drive Roller or loss of Take-up travel.

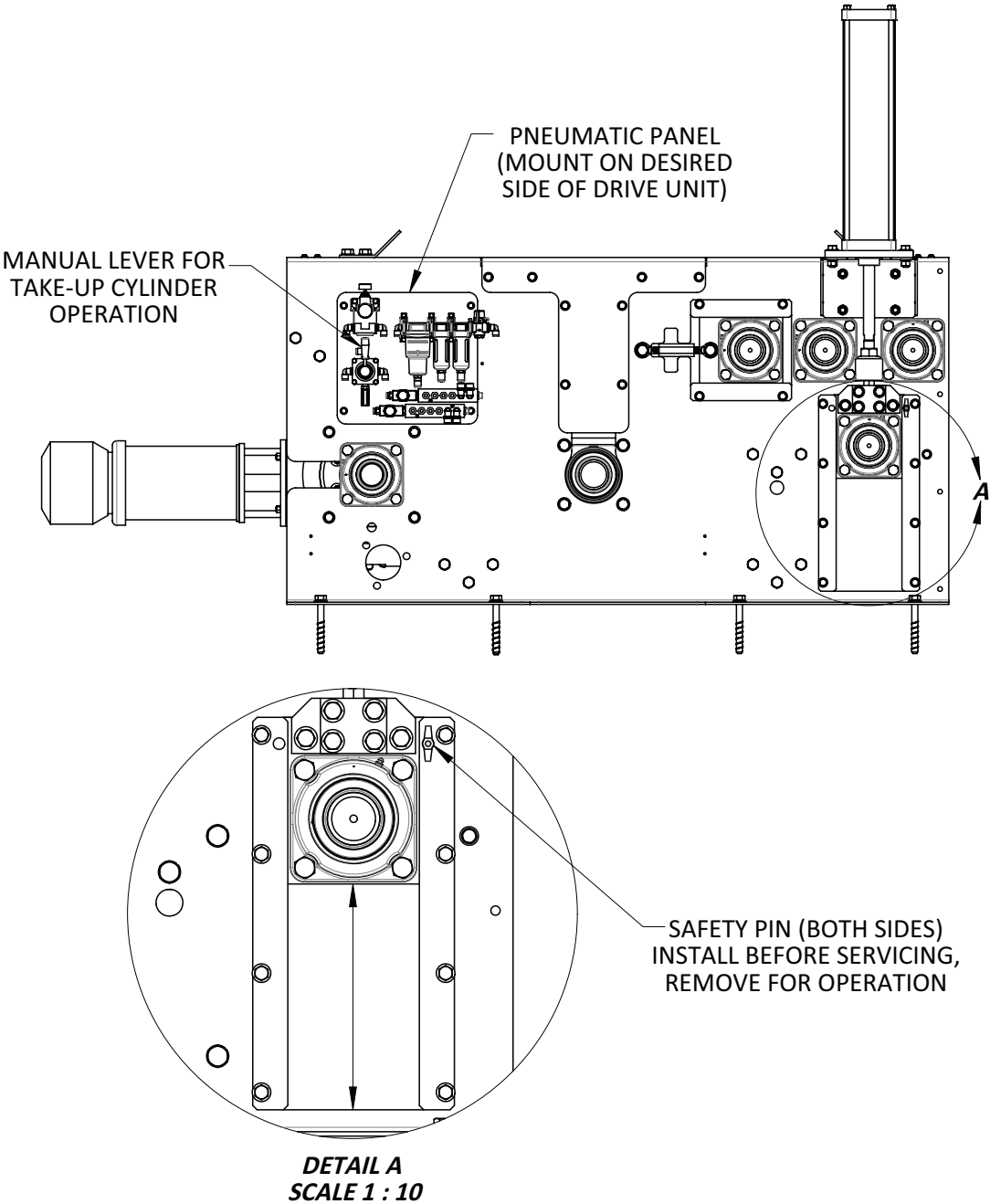

Installation

- 22. Trim Belt corners to ease threading through system.
- 23. Add a hole in the center of the Belt to attach rope.

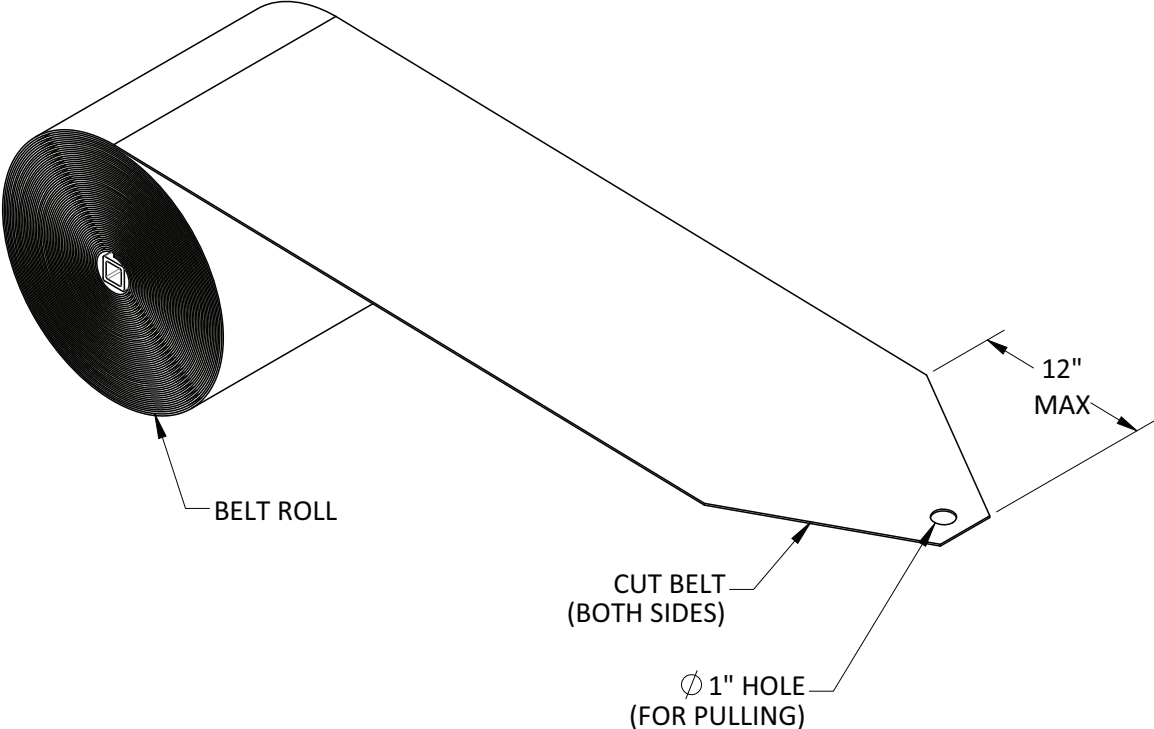

24. Thread rope through system as shown below starting on the bottom side of the system.



Failure to observe will result in slippage between Belt and Drive Roller or loss of Take-up travel.

25. Use Drive Roller to thread Belt.



Rope should be wrapped only once around Drive Roller.
Speed of Drive Roller should be set to minimum via the Variable Frequency Drive.
Drive Roller direction must be reversed.

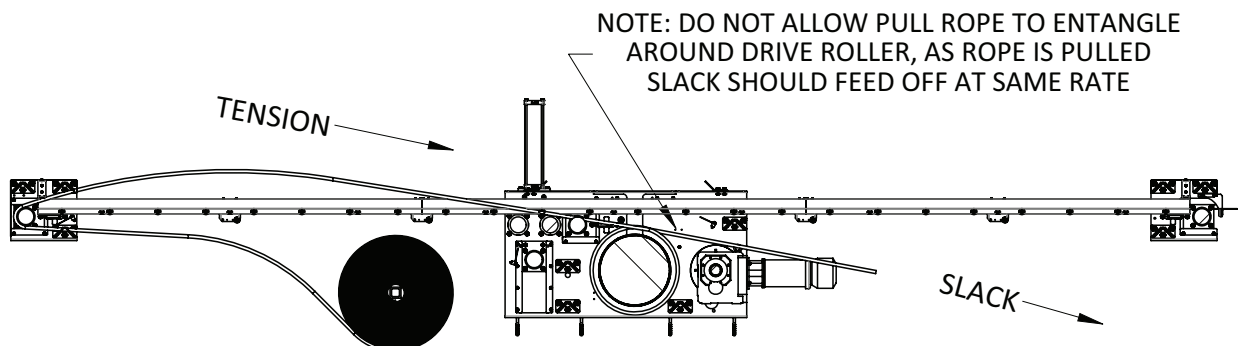
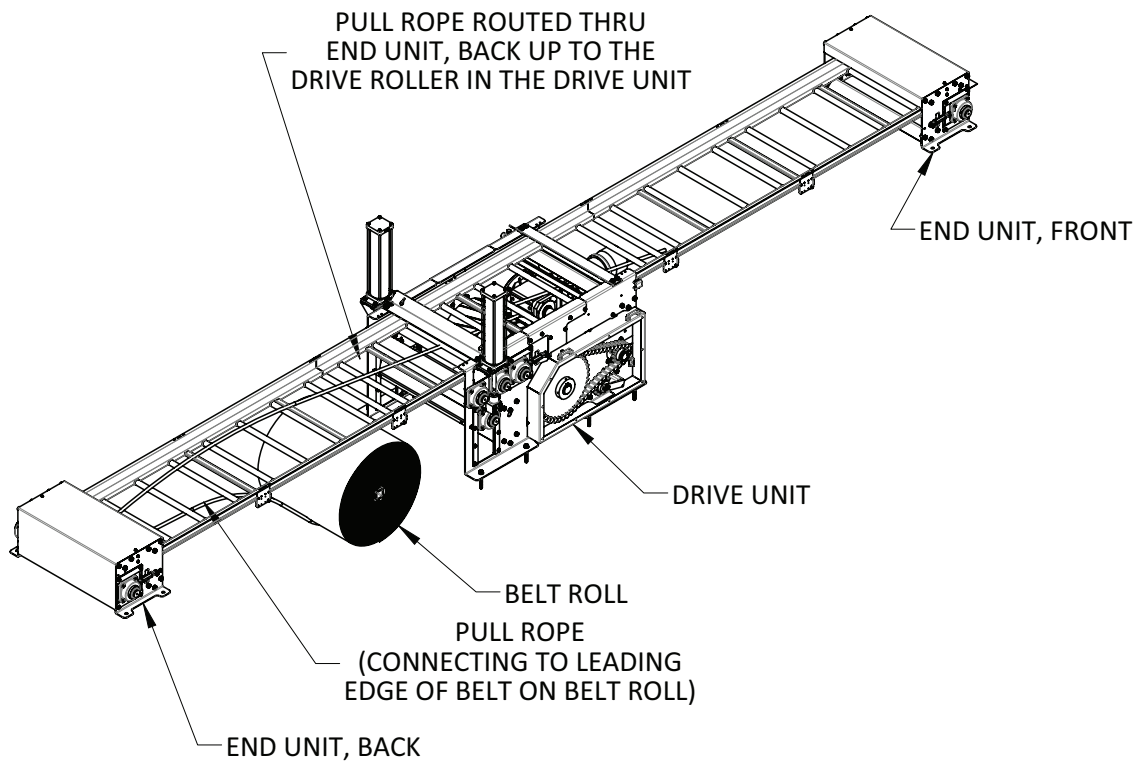

Installation

26. Hold tension on free end of rope to start threading.

27. Stop pulling when Belt reaches Drive Roller.



Stay clear of nip points and rope entanglement.
Stay clear of high tension rope.

NOTE: PULL ROPE WILL ROUTE BELT UP TO THE DRIVE UNIT, DO NOT ATTEMPT TO PULL BELT COMPLETELY THRU SYSTEM

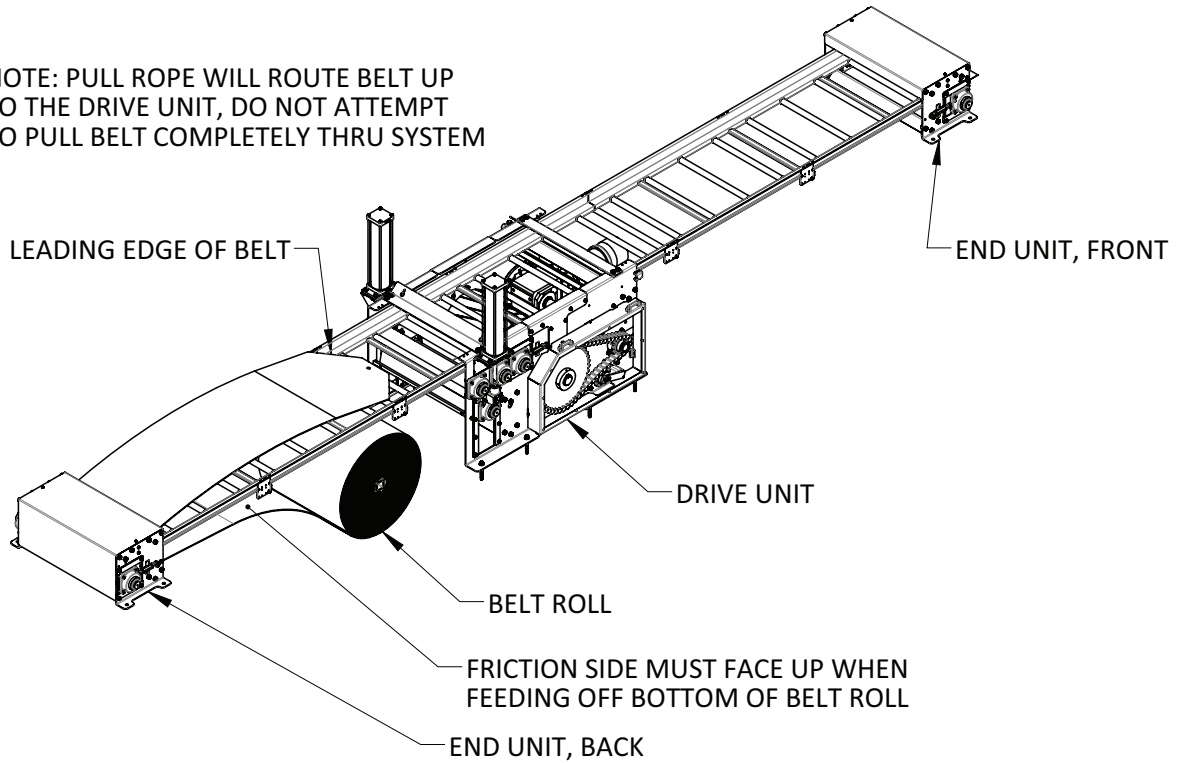

NOTE: STOP PULLING BELT WITH PULL ROPE WHEN APPROACHING DRIVE UNIT

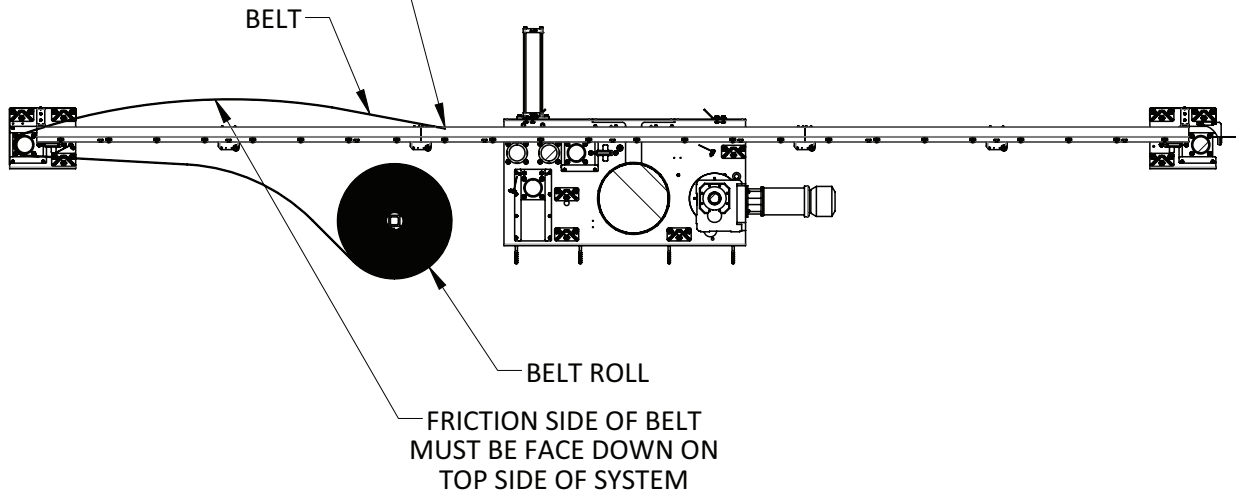

28. Thread opposite end of Belt through Drive Unit and End Unit, Front meeting opposite end of Belt on top side of system. Ends should meet outside Drive Unit for ease of Belt cutting/splicing.
29. Overlap Belt approximately 16 inches. Amount of overlap should ensure complete removal of any cuts, holes, or damage previously made on Belt.
30. Mark the overlap location on the top Belt layer, measure 3-inches and mark (this will become the cut location).



Do not cut Belt at this time!

31. On the bottom Belt Layer, measure 3-inches from the end and mark (this will become the cut location for this end of Belt).



Do not cut Belt at this time!

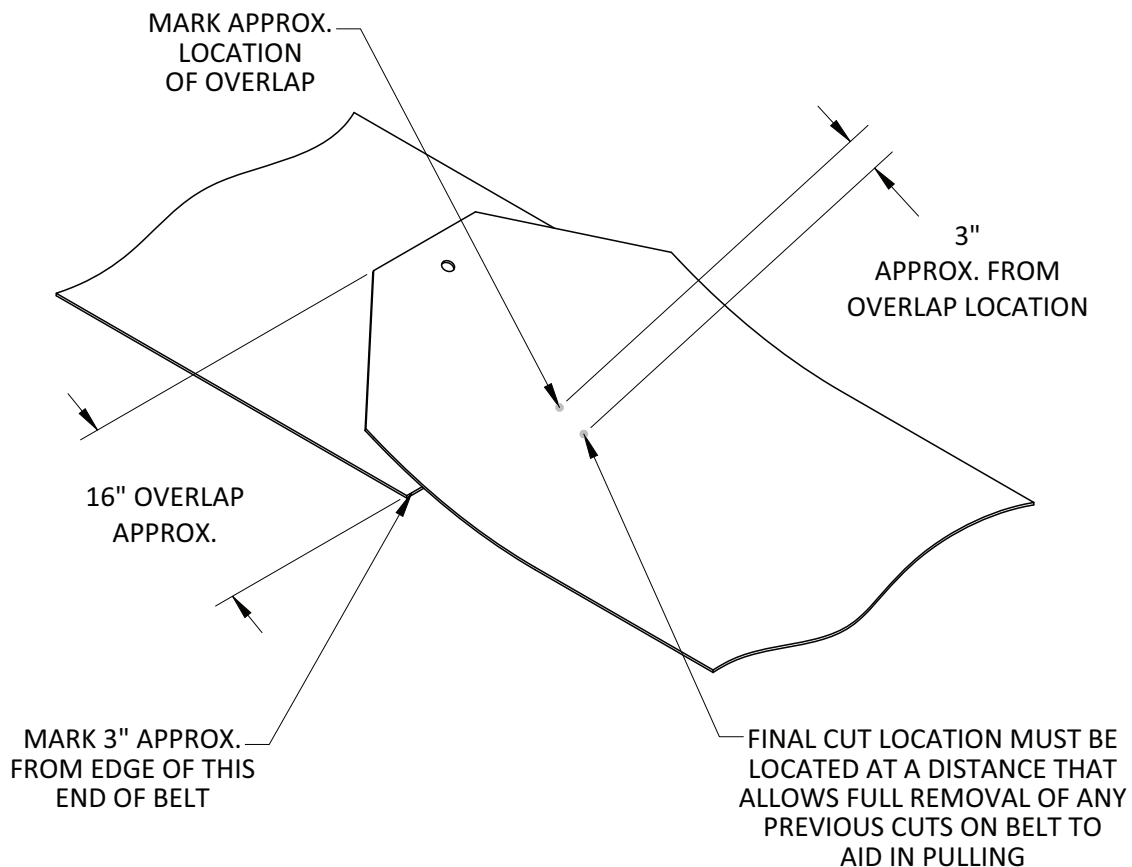

Belt Cutting

32. Mark the 6-ft level in the approximate center as a reference point.
33. Align the corners of the level with the sides of Belt.
34. Move the level down Belt, transferring marks on Belt that corresponds to the center mark on the level. Ensure the corners of level are aligned with the sides of Belt before each mark is made. A minimum of five marks should be transferred onto Belt.
35. Align level with marks and draw a line. Line is parallel with Belt Travel.

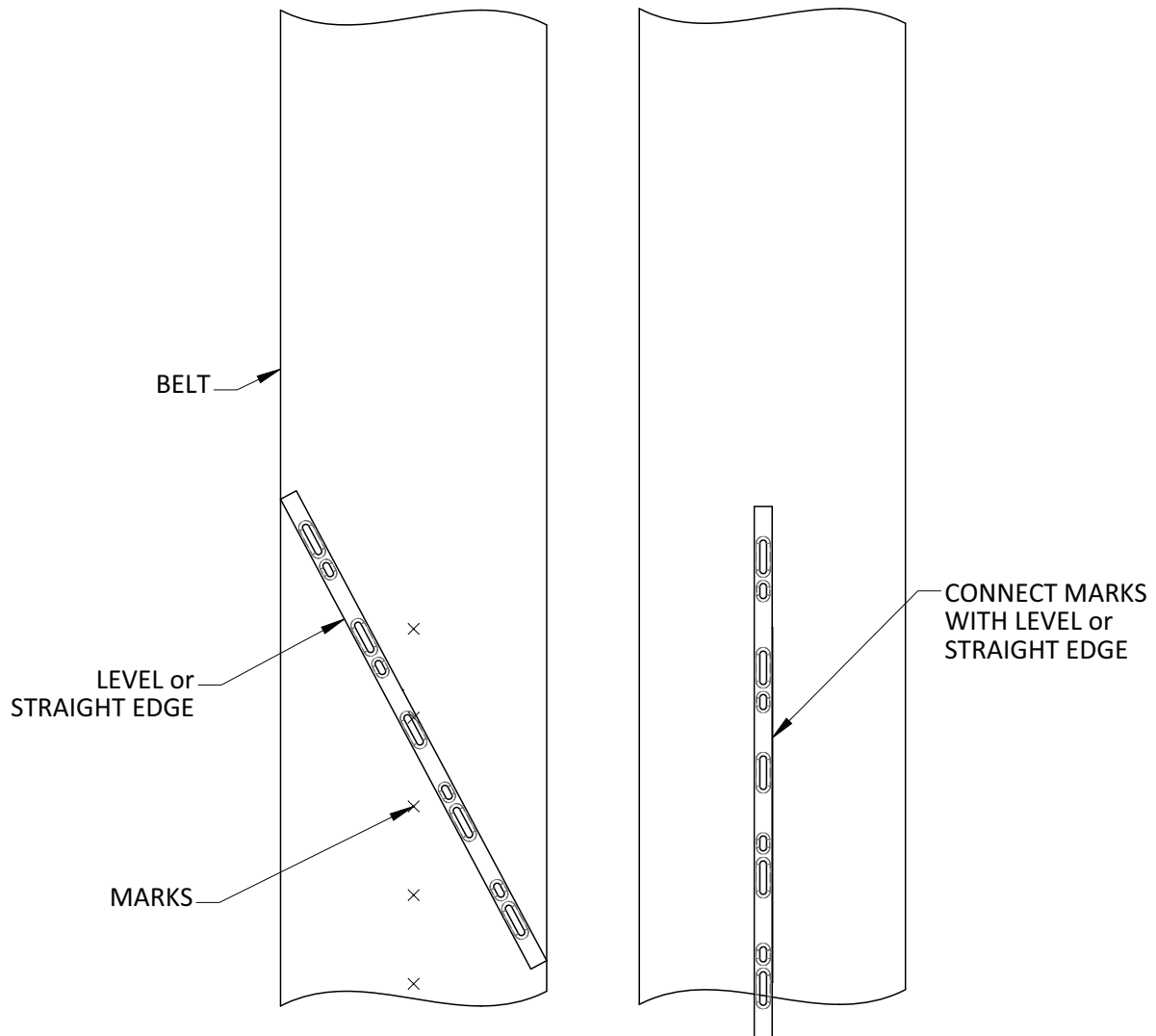

36. Align framing square with parallel line.
37. Align level with framing square and draw perpendicular line at cut location.
38. Use level to ensure straight cut.

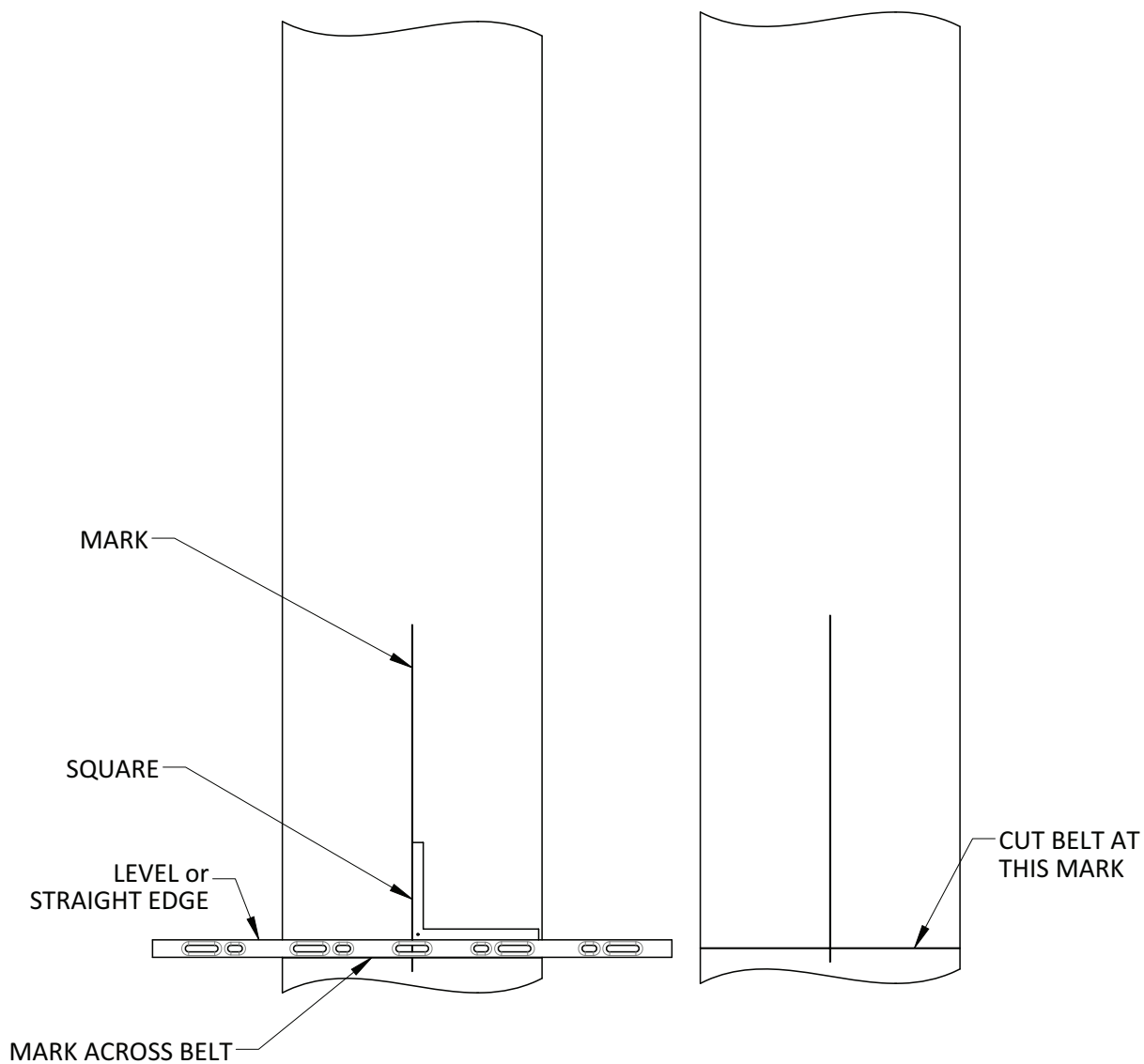

Installation

39. After cutting both Belt ends, an approximate 6-inch gap should remain.

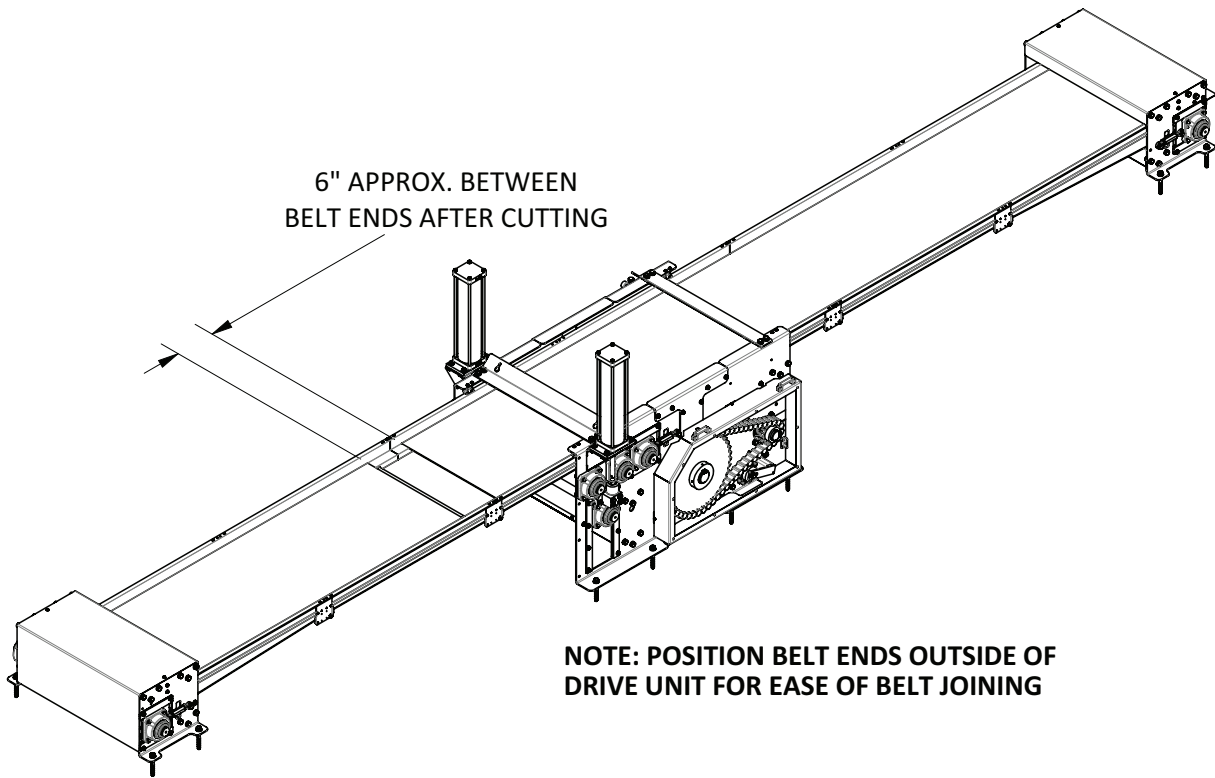

Belt Splicing

- 40. Refer to *Flexco Alligator Lacing* manual for proper Belt Splicing procedures.
- 41. Refer to *Flexco Far-Pul HD Belt Clamp* manual for proper Belt Joining procedures.
- 42. Remove Safety Pins and apply air pressure to tension Belt using the Hand Valve.

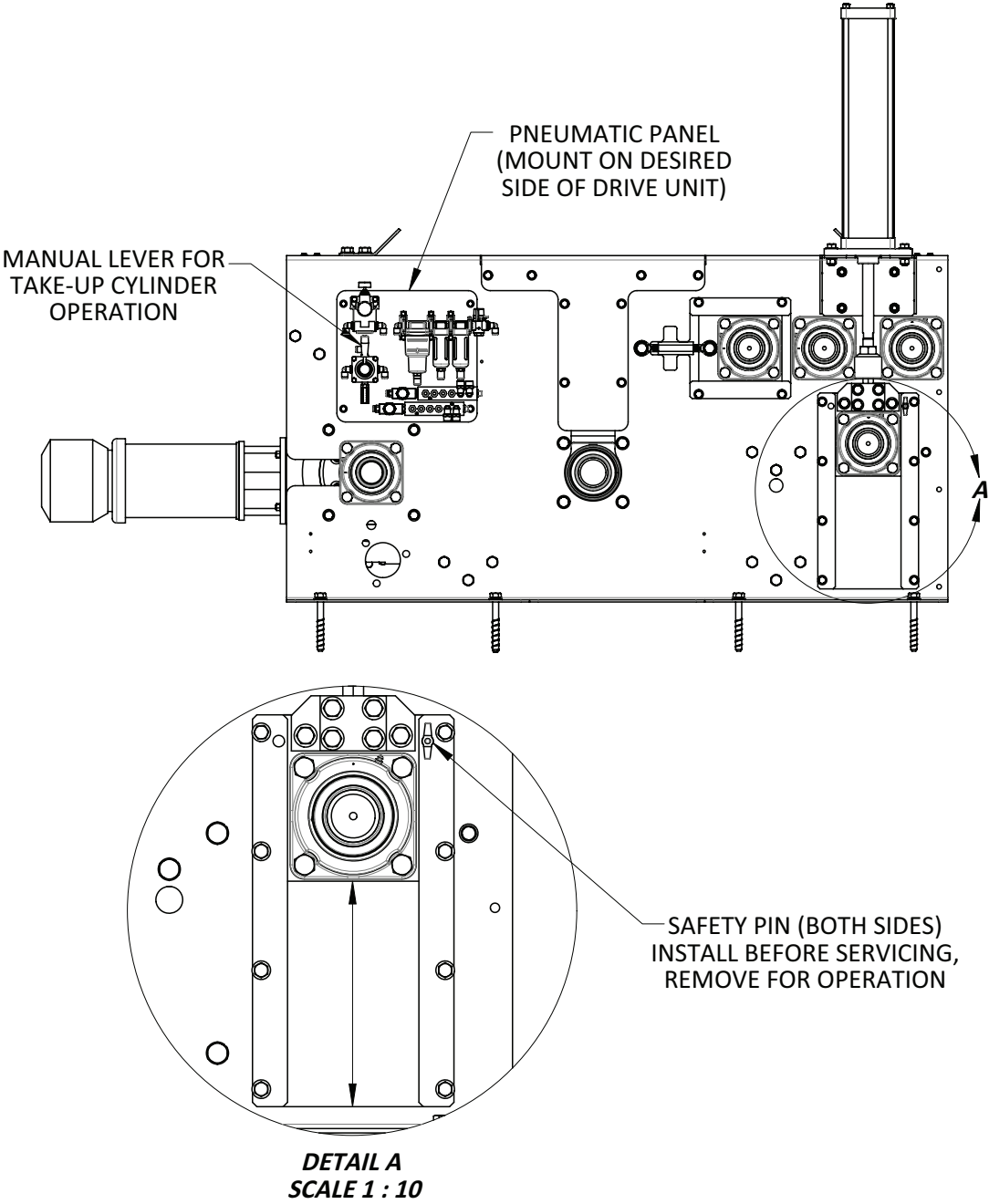

Transfer Plate Adjustment



Adjust Transfer Plate to user's needs.
Adjust Transfer Plate to allow clearance for Belt Splice(s).

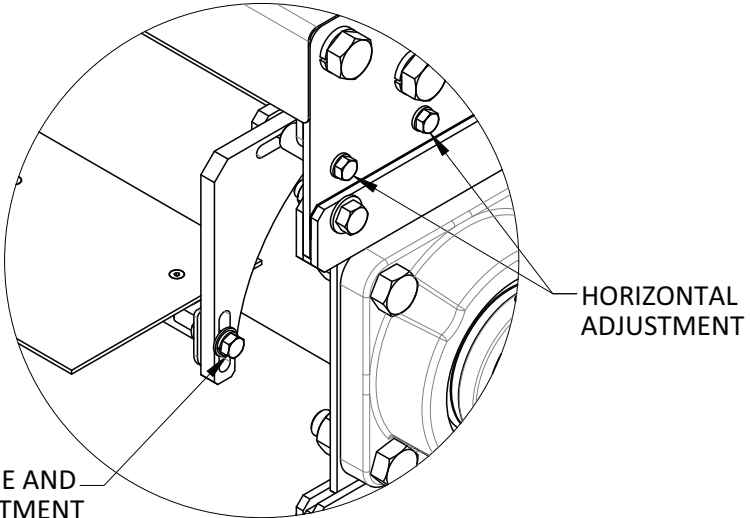
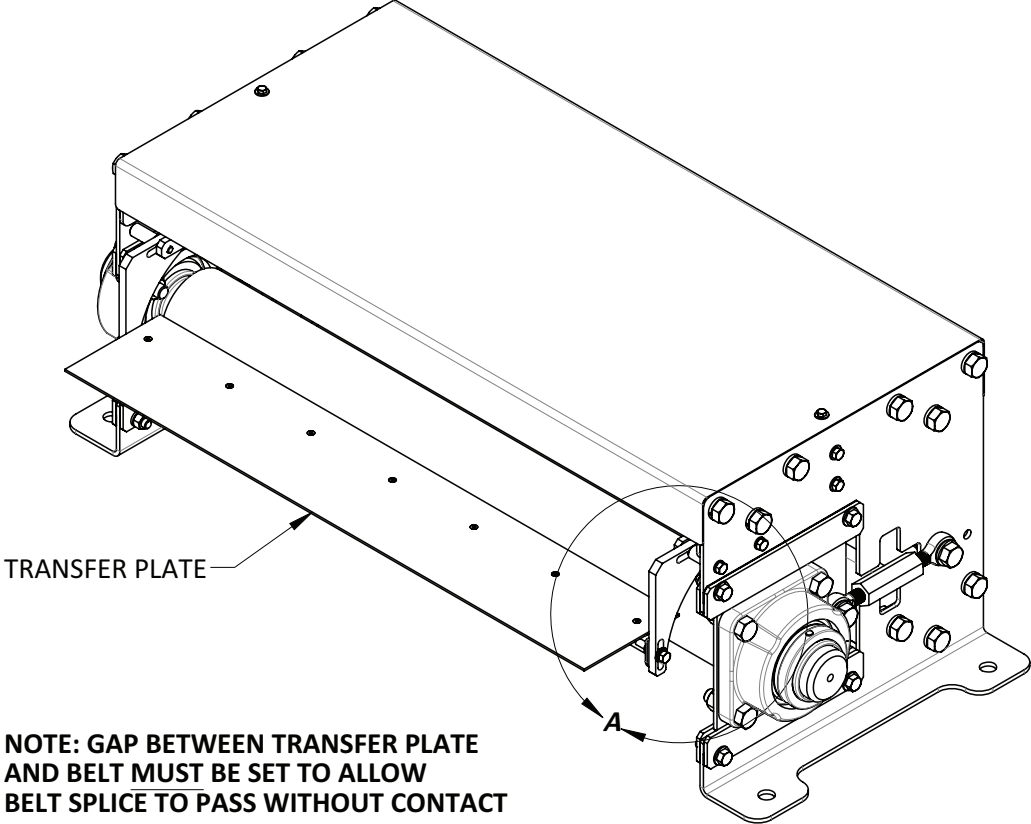

DETAIL A
SCALE 1 : 5

Belt Scraper Adjustment, Drive Unit

43. Loosen bolts securing Belt Scraper. Pivot assembly until contacting Belt with slight pressure and tighten. Adjust pressure if results are not desirable.

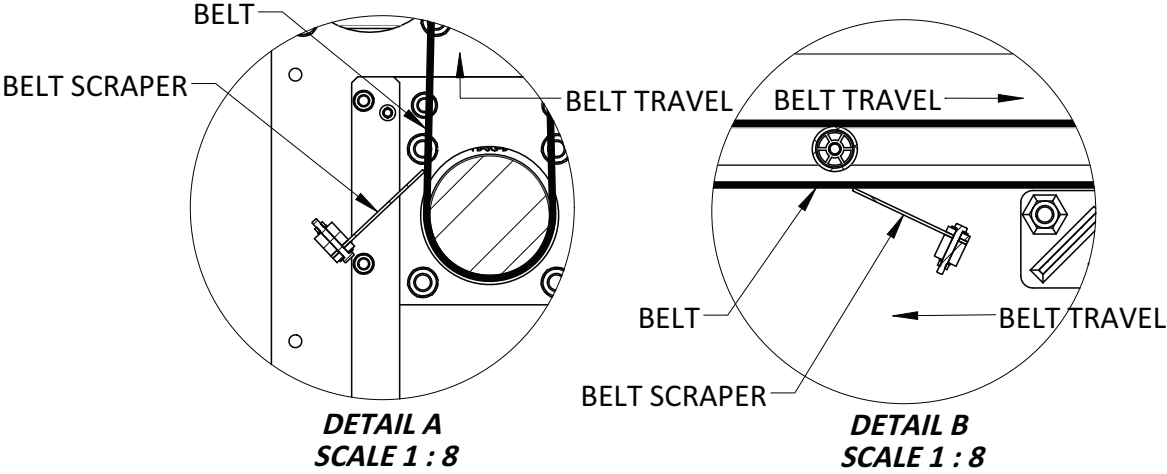
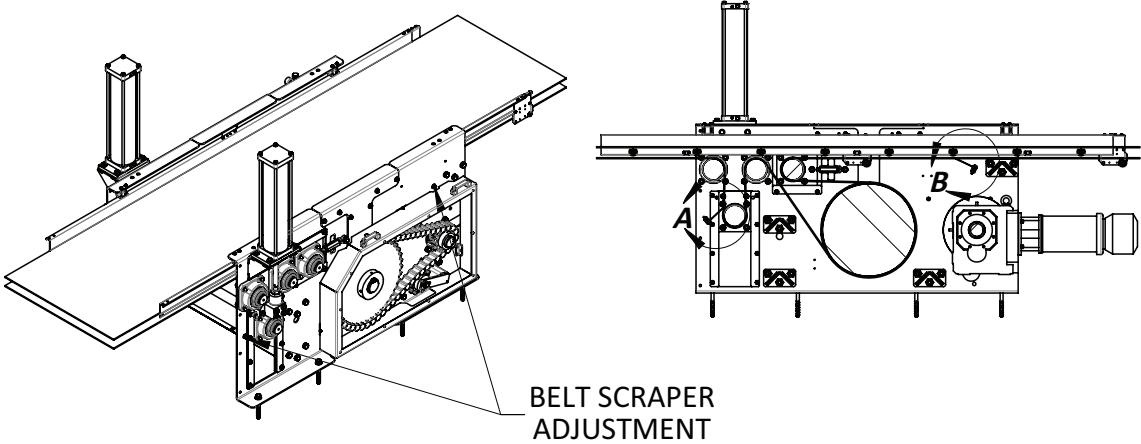

Belt Scraper Adjustment, End Unit

44. Repeat steps performed on Drive Unit to adjust End Unit Belt Scraper.

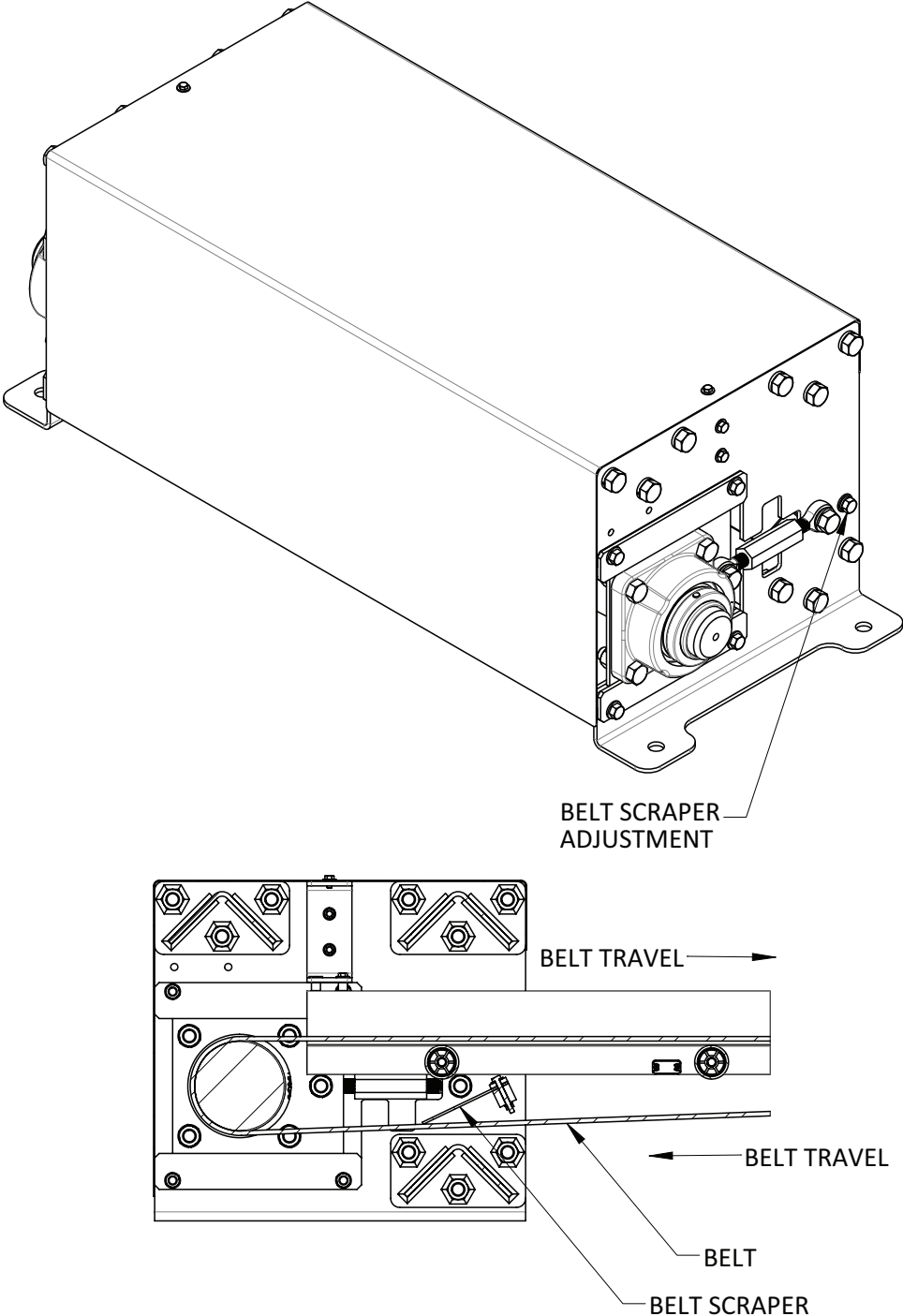

SECTION 4 START-UP & TROUBLESHOOTING

System Start-Up



Verify all electrical and pneumatic systems for proper operation before System Start-Up.
Wear necessary Personal Protective Equipment prior to any work.
Observe all Lockout/Tagout procedures prior to performing work on system.

1. Verify all components are installed and anchored properly according to installation manual.

Note: Failure to install system as engineered by Lubing Systems may result in poor system performance and/or damage to system and product.

2. Ensure any obstructions or foreign objects are clear of Belt.
3. Verify all personnel are clear prior to starting system or engaging Take-up Assembly.
4. Remove Safety Pins and engage Take-Up Assembly.
5. Set Variable Frequency Drive at a minimum frequency to ensure Belt will move at a minimum rate of travel. Place observers at each End Unit and Drive Unit, prepared to adjust Belt tracking.
6. Start the system at a minimum rate of travel, verifying the Belt is centered in system, and for slippage at the Drive Roller. If slippage is observed, increase pressure at Regulator on Pneumatic Panel. Do not exceed recommended maximum air pressure for any pneumatic components.

Note: Failure to start system at a minimum rate of travel could result in Belt tracking off rollers or cause damage to Belt and/or other components of system.

Belt Tracking

- Using Turnbuckles located on both sides of the Drive Unit and End Units, adjust Belt tracking.
- Adjust Turnbuckles until the Belt rides centered on system.



Tracking adjustments on Drive Unit affect Belt alignment through Drive Unit only.
Tracking adjustments on End Units affect Belt alignment through End Units only.
Tracking adjustments must be performed while system is running.
Make slight tracking adjustments and allow Belt to respond before proceeding.

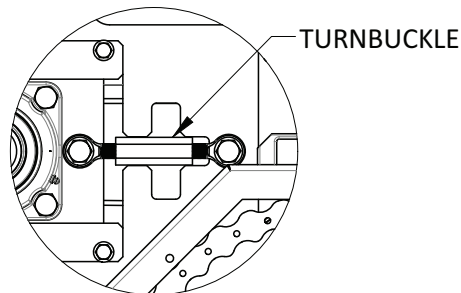
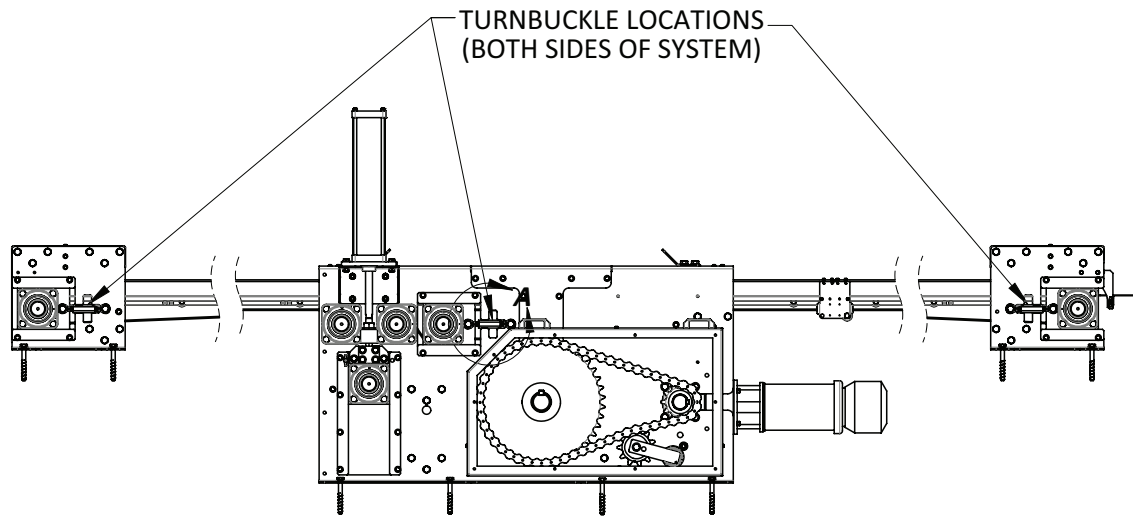

DETAIL A
SCALE 1 : 10

Start-Up and Troubleshooting

9. Once Belt is tracking properly, increase rate of travel while ensuring tracking remains consistent. Increase rate until desired speed and tracking are obtained.
10. Beginning at the End Unit, Front, walk system looking and listening for any potential issues that may indicate improper operation. If any issues are found, stop system immediately and resolve.

Note: Do not continue running system if there are indications of improper operation, it is important to make necessary corrections before starting system again.

11. After confirming system is free of issues, begin trial runs of product.
12. With system running, begin applying product to Belt.

Note: Make adjustments to upstream equipment to ensure a smooth transfer of product onto system.

13. With product on Belt, follow the product as it advances through system, looking for issues occurring under load.

Note: System will respond differently as load is applied. It is important to observe the operation of system as product passes through. If issues occur during this process, stop system and refer to the *Troubleshooting* section of the manual.

14. Follow the product as it advances through system until reaching the end, being certain to monitor the transition of product onto downstream equipment.

Note: Refer to the End Unit, Front *Component Assembly and Installation Instructions* for assistance in adjusting the Transfer Plate.

Belt Speeds

Belt Width (inches)	Belt Speed (ft/min)	VFD Frequency (Hz)
24	23	60
36		
48	26	

System Break-In

Note: System will require special attention during the first weeks of operation. During this time, inspect the system and adjust as needed to ensure proper break-in. Use the *Break-In Inspection Schedule* below to monitor system during this period.

Note: The *Break-In Inspection Schedule* should be followed anytime a new component or section of belt is added or removed from system.

Note: The duration of the break-in period will vary depending upon operating load, run time, start/stop occurrences, and other factors.

Break-In Inspection Schedule

Hourly		
	Drive Unit	<ul style="list-style-type: none">Inspect the Drive roller for slippageMonitor for unusual sounds and/or vibrationsInspect Belt tracking
	End Unit, Front	<ul style="list-style-type: none">Monitor for unusual sounds and/or vibrationsVerify Transfer Plate adjustmentInspect belt tracking
	End Unit, Back	<ul style="list-style-type: none">Monitor for unusual sound and/or vibrationsInspect Belt tracking

Start-Up and Troubleshooting

Troubleshooting

General Troubleshooting	Improper belt alignment	<ul style="list-style-type: none"> Inspect splices to ensure no separation has occurred Inspect Rollers for debris
	Belt Splice separation	<ul style="list-style-type: none"> Verify clearance at collectors Inspect for any contact as Splice passes through system
	Drive Roller slippage	<ul style="list-style-type: none"> Verify Take-Up Assembly is engaged Verify incoming air pressure Inspect air lines for restrictions or leaks Inspect Drive Roller for debris (dry or wet)
	Drive Unit or End Unit noise	<ul style="list-style-type: none"> Inspect Unit for loose components or fasteners Inspect for damaged bearings Inspect Drive Chain for proper tension Inspect Drive Chain Tensioner for proper operation Verify all drive components are properly secured Verify Belt Scrapers are secured
	Excessive dirt on belt	<ul style="list-style-type: none"> Check belt scrapers to ensure proper alignment Check scraper plates on belt scraper to ensure they do not need replacing
	Product damage	<ul style="list-style-type: none"> Inspect transfer points onto and off the system for proper adjustment Verify product path is clear through entire system Verify Sidesheet cutouts at collectors are properly deburred Check Drive Unit and End Units for excessive vibrations and harmonics

SECTION 5 MAINTENANCE

Preventive Maintenance

- The Drive Roller should be checked for debris before each startup. If present, clean prior to startup.
- The airlines should be visually checked for restrictions and leaks prior to startup. Replace as needed.
- The Belt Scrapers on the Drive Unit and End Unit should be checked daily for proper engagement prior to startup.
- Maintain all bearings on the Drive Unit and End Units per the manufacturer's recommendations.
- Maintain the Air Filter and Mist Separator per the manufacturer's recommendations.
- The Drive Chain should be inspected and maintained per the manufacturer's recommendations.
- The Gearbox and Motor should be inspected and maintained per the manufacturer's recommendations.

Inspection Schedule

Daily	General	<ul style="list-style-type: none"> • Verify all guards and covers are in place and secure. • After start-up inspect the Drive Roller for slippage, adjust air pressure as needed at the Regulator. Do not exceed manufacturer's recommendations. • While system is running, walk the entire length looking for abnormalities and listening for sounds that could indicate damage to one or more of the system components.
	Drive Unit	<ul style="list-style-type: none"> • Before running system, inspect all rollers to ensure rolling surface is free of debris (dry or wet). • After system is running, monitor for unusual sounds and/or vibrations. • Inspect Belt Scraper for proper adjustment.
	End Unit, Back	<ul style="list-style-type: none"> • Before running system, inspect all rollers to ensure they are free of debris (dry or wet). • After system is running, monitor for unusual sounds and/or vibrations. • Inspect Belt Scraper for proper adjustment.
	End Unit, Front	<ul style="list-style-type: none"> • Before running system, inspect all rollers to ensure they are free of debris (dry or wet). • After system is running, monitor for unusual sounds and/or vibrations. • Inspect Transfer Plate for proper adjustment.
1 to 3 Months	General	<ul style="list-style-type: none"> • Inspect Belt Splices for signs of wear or separation.
	Drive Unit	<ul style="list-style-type: none"> • Inspect the Gearbox for leaks and proper fluid level. • Inspect all bearings for excessive wear. • Inspect roller journals for excessive wear.
	End Unit, Back	<ul style="list-style-type: none"> • Inspect all bearings for excessive wear.
	End Unit, Front	<ul style="list-style-type: none"> • Inspect all bearings for excessive wear.

Maintenance

Inspection Schedule Continued

3 to 6 Months	Drive Unit	<ul style="list-style-type: none">• Inspect Chain Sprockets for excessive wear on teeth• Inspect Drive Chain for proper tensioning.• Inspect Drive Roller for wear of rubber cladding.• Inspect for loose components or fasteners.• Inspect Belt Scraper, replace Scraper Plate if adjustment does not allow contact with Belt.
	End Unit, Back	<ul style="list-style-type: none">• Inspect Belt Scraper, replace Scraper Plate if adjustment does not allow contact with Belt.• Inspect for loose components or fasteners.
	End Unit, Front	<ul style="list-style-type: none">• Inspect for loose components or fasteners.• Inspect Transfer Plate for proper adjustment.
12 to 18 Months	General	<ul style="list-style-type: none">• Clean and inspect all belt contact surfaces.• Inspect Drive Roller for wear of rubber cladding.

Critical Spares All Widths

Part Number	Description	Recommended Min. Qty.	Drive Unit	End Unit, Front	End Unit, Back	Connecting Part	Modular Take-up Unit
704 010 25 00	4-Bolt Flange Bearing, 3"	2	•	•	•		•
704 010 26 00	4-Bolt Flange Bearing, 2-3/4"	2	•				
704 010 27 00	4-Bolt Flange Bearing, 3-7/16"	2	•				
131612	7.5HP 3PH AC Brake Motor	1	•				
TIUB11B-20	Polyurethane Tubing, 3/8", 20m Roll	1	•				•
CS2F140TN-600	140mm Bore, 600mm Stroke Cylinder	1	•				•

Critical Spares 24-in

Part Number	Description	Recommended Min. Qty.	Drive Unit	End Unit, Front	End Unit, Back	Connecting Part	Modular Take-up Unit
700 010 37 00	Tapered Roller, 24-in	1	•		•		
700 010 36 00	Straight Roller, 24-in	1	•	•			•
700 214 02 00	Belt Scraper Plate, 24-in	2	•		•		
700 020 09 00	Transfer Plate, 24-in	1		•			
700 130 01 04	Top Roller Assembly, 24-in	8				•	
700 130 02 04	Bottom Roller Assembly, 24-in	2				•	
U4S12	Unibar SS Lace (12')	1					
NYS093C	Nylostainless Pin (25' Coil)	1					
700 050 01 00	Belt PVC 200# 24" COSXMSK White (ft)	50					

Critical Spares 36-in

Part Number	Description	Recommended Min. Qty.	Drive Unit	End Unit, Front	End Unit, Back	Connecting Part	Modular Take-up Unit
702 010 37 00	Tapered Roller, 36-in	1	•		•		
702 010 36 00	Straight Roller, 36-in	1	•	•			•
702 214 02 00	Belt Scraper Plate, 36-in	2	•		•		
702 020 09 00	Transfer Plate, 36-in	1		•			
702 130 01 04	Top Roller Assembly, 36-in	8				•	
702 130 02 04	Bottom Roller Assembly, 36-in	2				•	
U4S12	Unibar SS Lace (12')	1					
NYS093C	Nylostainless Pin (25' Coil)	1					
702 050 01 00	Belt PVC 200# 36" COSXMSK White (ft)	50					

Critical Spares 48-in

Part Number	Description	Recommended Min. Qty.	Drive Unit	End Unit, Front	End Unit, Back	Connecting Part	Modular Take-up Unit
704 010 05 00	Tapered Roller, 48-in	1	•		•		
704 010 06 00	Straight Roller, 48-in	1	•	•			•
704 214 02 00	Belt Scraper Plate, 48-in	2	•		•		
704 020 04 00	Transfer Plate, 48-in	1		•			
704 130 01 00	Top Roller Assembly, 48-in	8				•	
704 130 02 00	Bottom Roller Assembly, 48-in	2				•	
U4S12	Unibar SS Lace (12')	1					
NYS093C	Nylostainless Pin (25' Coil)	1					
704 050 01 00	Belt PVC 200# 48" COSXMSK White (ft)	50					

Belt Cleaning

Cleaning Practices

If the conveyor must be cleaned; it is imperative that only water is used and not a chemical solution as damage could occur due to incompatibility with the belt material. Care must be taken to not wet the underside (friction surface) of the belt as this can cause corrosion and/or the accumulation of debris along the sliding surfaces. When possible, use cloths or other cleaning methods to spot clean the affected areas without introducing excessive amounts of running water onto the belt and sliding surfaces. It is the best practice to perform any cleaning near the front of the conveyor to allow the belt maximum dry time as it travels on the underside of the conveyor before reaching the sliding surfaces on the top side.

Things to Avoid

- UV light is becoming another common sanitizer due to its effectiveness. However, over time, this will also cause damage to the belt.
- Do not use chemical solutions to clean the belt surface. Possible incompatibility with the belt material could cause corrosion and splice damage.
- The belt should be set to the appropriate pressure setting according to the charts in the PRESSURE SETTINGS section on the next page. Failure to use the correct pressure setting will result in damage to the splices and belt.

Pressure Settings

24-in System Pressure Setting Recommendation

The belt air pressure must be adjusted depending on length and width. The following charts provide a visual and the maximum air pressure should not be exceeded.

It is recommended that the air pressure setting be adjusted to the lowest pressure possible that does not allow belt slippage on the Drive Roller during peak egg load.

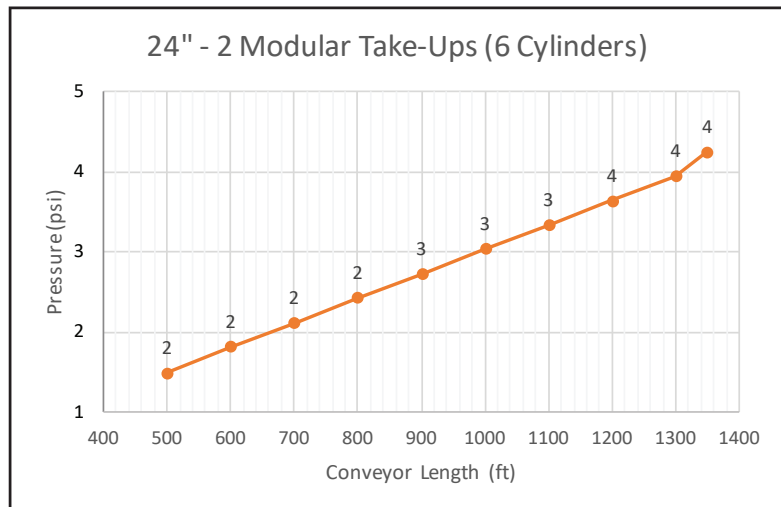
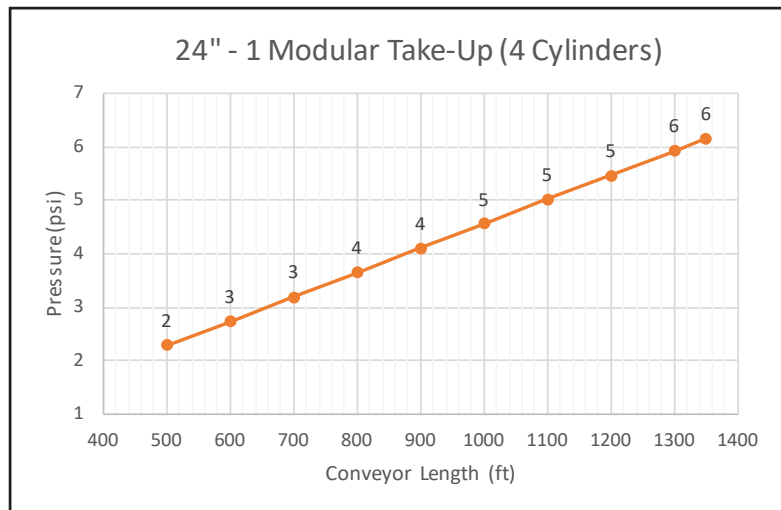
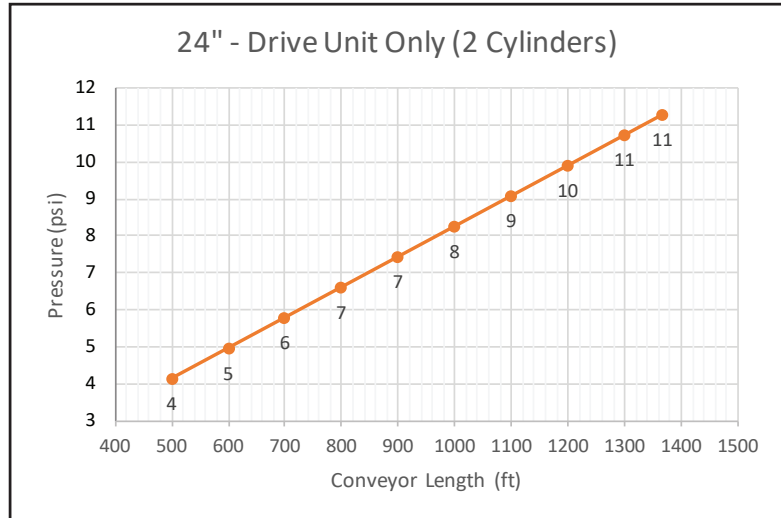

Pressure Settings

36-in System Pressure Setting Recommendation

The belt air pressure must be adjusted depending on length and width. The following charts provide a visual and the maximum air pressure should not be exceeded.

It is recommended that the air pressure setting be adjusted to the lowest pressure possible that does not allow belt slippage on the Drive Roller during peak egg load.

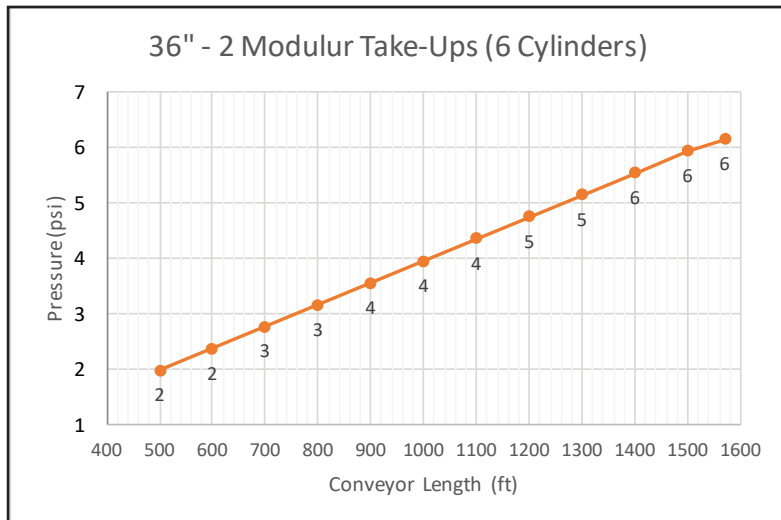
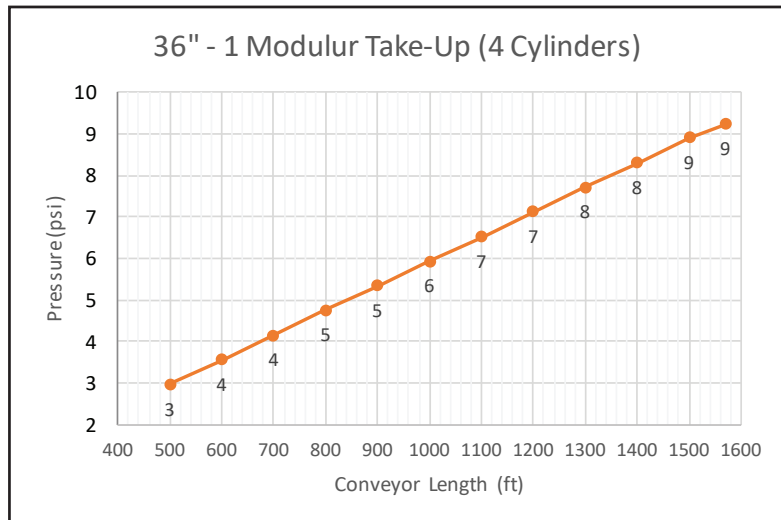
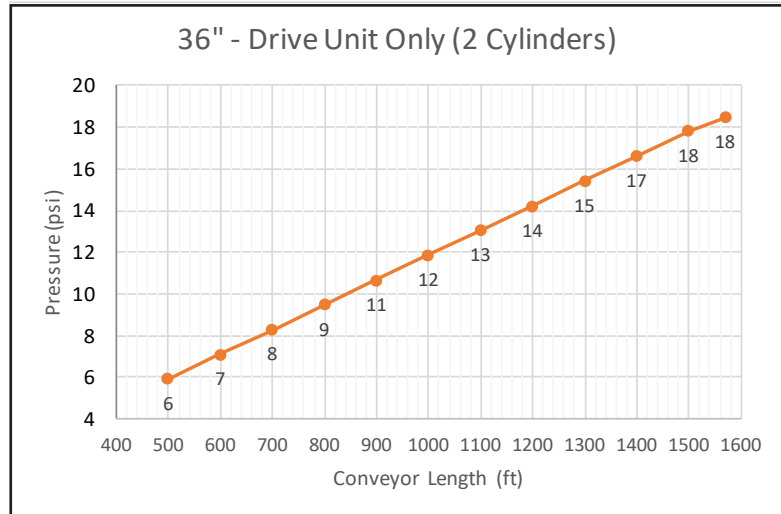

Pressure Settings

48-in System Pressure Setting Recommendation

The belt air pressure must be adjusted depending on length and width. The following charts provide a visual and the maximum air pressure should not be exceeded.

It is recommended that the air pressure setting be adjusted to the lowest pressure possible that does not allow belt slippage on the Drive Roller during peak egg load.

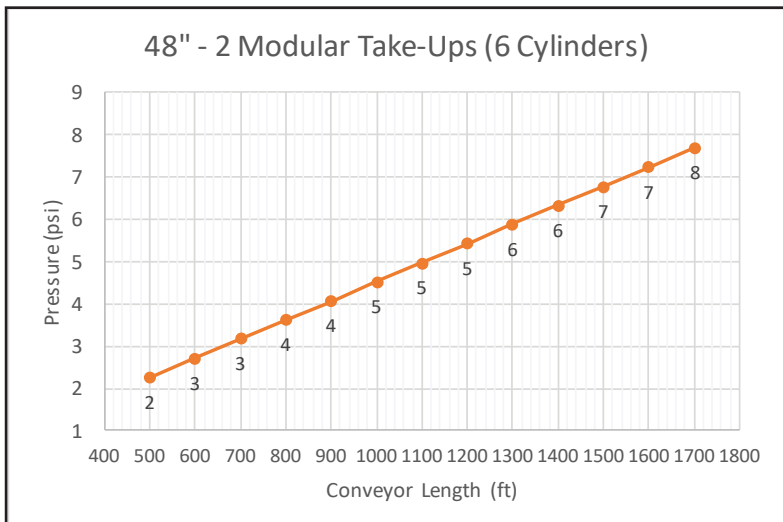
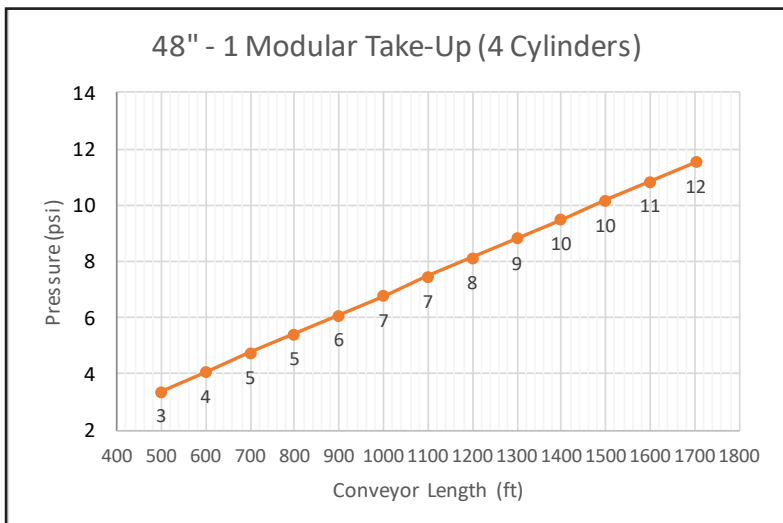
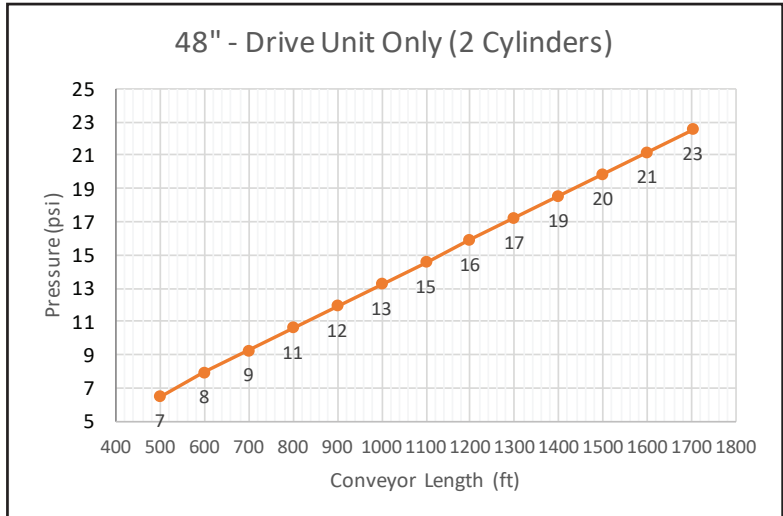

SECTION 6 GENERAL INFORMATION

OEM Contact Information

Stober USA

1781 Downing Drive

Maysville, KY 41056 USA

(606) 759-5090 Phone

(800) 711-3588 Phone

888-4-STOBER (786237) FAX

www.stober.com Company Website

sales@stober.com Tech Support Email Address

Marathon Electric - Motors Division

100 E. Randolph Street, PO Box 8003

Wausau, WI 54401-8003

(715) 675-3311 Phone

www.marathonelectric.com Company Website

motor.help@marathonelectric.com Tech Support Email Address

Lubing Contact Information

Lubing Systems, L.P.

**135 Corporate Drive SW
Cleveland, TN 37311 USA**

**423 709.1000 telephone
866 289.3237 toll-free fax**

Website: www.lubingusa.com

General Requests: info@lubingusa.com

Customer Service/Ordering: customerservice@lubingusa.com

Technical Support: engineering@lubingusa.com

LUBING

Contact your local Lubing Distributor or Representative for additional information regarding Lubing products.

Northeast/Canada MA,VT, NH, ME, RI, CT, NY, NJ, PA, DE,
GEORGE BAILEY MD, VA, WV, NC, MI, OH
Cell: (540) 908-8899 East Canada: MB, ON, QC, NB, NL, PEI
Fax: (540) 433-7400
E-mail: gbailey@lubingusa.com

Southeast AL, FL, GA, KY, IN, MS, LA, SC, TN
BARRY DUTTON
Cell: (205) 612-5625
Fax: (240) 368-8784
E-mail: bdutton@lubingusa.com

Midwest/Canada AK, AR, CO, KS, MO, ND, NE, NM,
STEVE KUYKENDALL OK, SD, TX
Cell: (469) 908-8899 West Canada: AB, SK, BC, YT, NT
Fax: (540) 433-7400
E-mail: skuykendall@lubingusa.com

West Coast AZ, CA, ID, NV, OR, UT, WA, MT, WY, HI
International Sales
KURT HUTT
Cell: (432) 464-0500
Fax: (423) 709-1001
E-mail: khutt@lubingusa.com

LUBING Systems, L.P.
135 Corporate Drive, SW
Cleveland, TN 37312 - USA
Tel: (423) 709-1000
Fax: (423) 709-1001
E-mail: info@lubingusa.com
E-mail: support@lubingusa.com