

Watering Systems.

Floor Watering Systems Installation Guide

For the following systems:

***Broilers, Breeders, Pullets, with
LitterGard Cups and without***

Instruction # IM-030-05

06/06

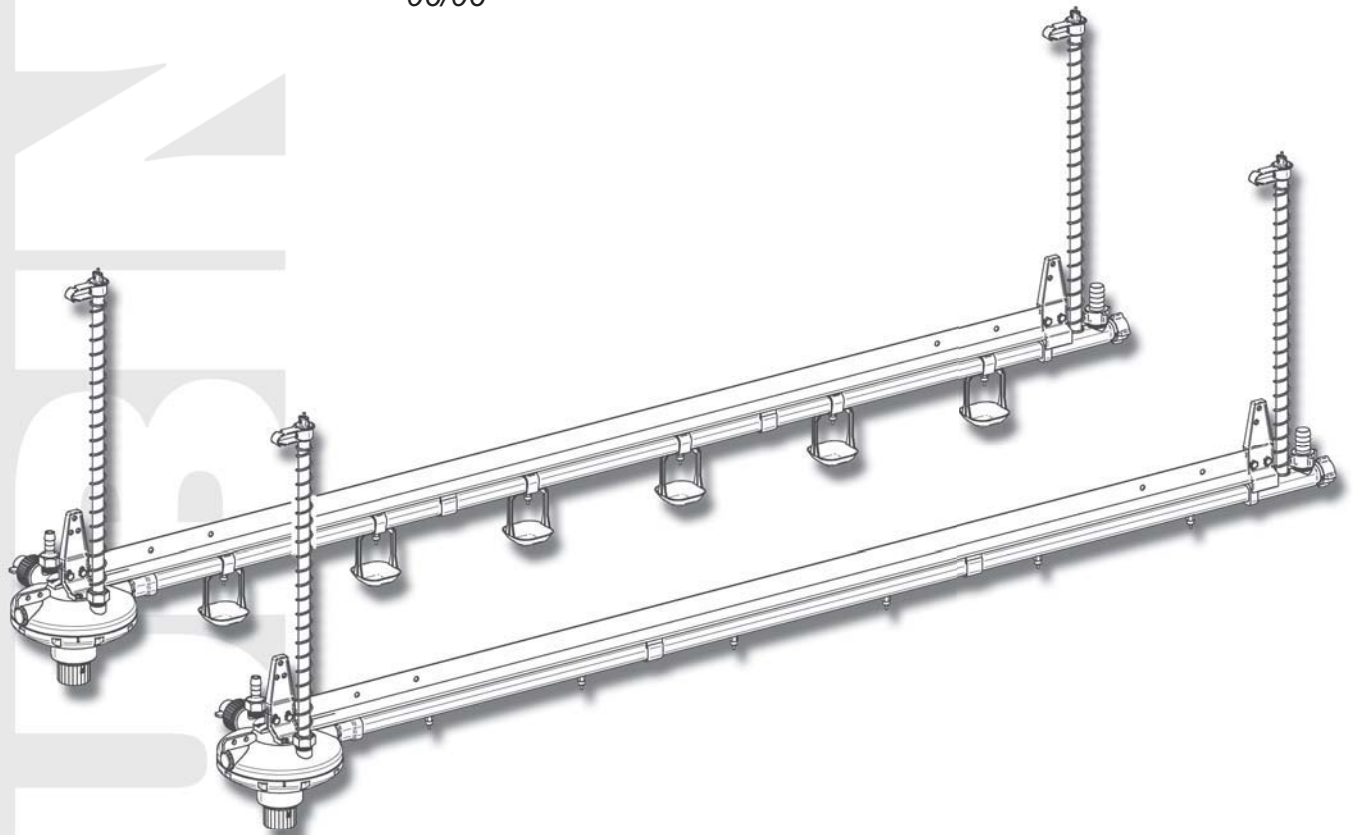

LUBING

System Overview

Please review this entire manual before starting the installation to familiarize yourself with the installation process.

Pictured below is an overview drawing of a complete watering system showing optional hose attachments. Lubing watering systems are available with Pressure Regulators or Ball Tank assemblies.

Pressure Regulators are designed with single and double outlet capabilities. The illustration below shows the regulator at the beginning of the line. The Pressure Regulator may also be used in the middle of the house with a double outlet configuration depending on the house length and slope.

Variations of these configurations are possible depending on the customers' needs and the building design.

Mid-line shut-off assemblies are available for partial house brooding as well as slope compensators. These are not illustrated below but will be discussed later in this manual.

All Lubing Watering Systems must be suspended from the ceiling with suspension equipment. Winching details will not be discussed in this installation manual.

NOTE:

280 ft [85m] max. length for 22mm pipe
560 ft [170m] max. length for 28mm pipe

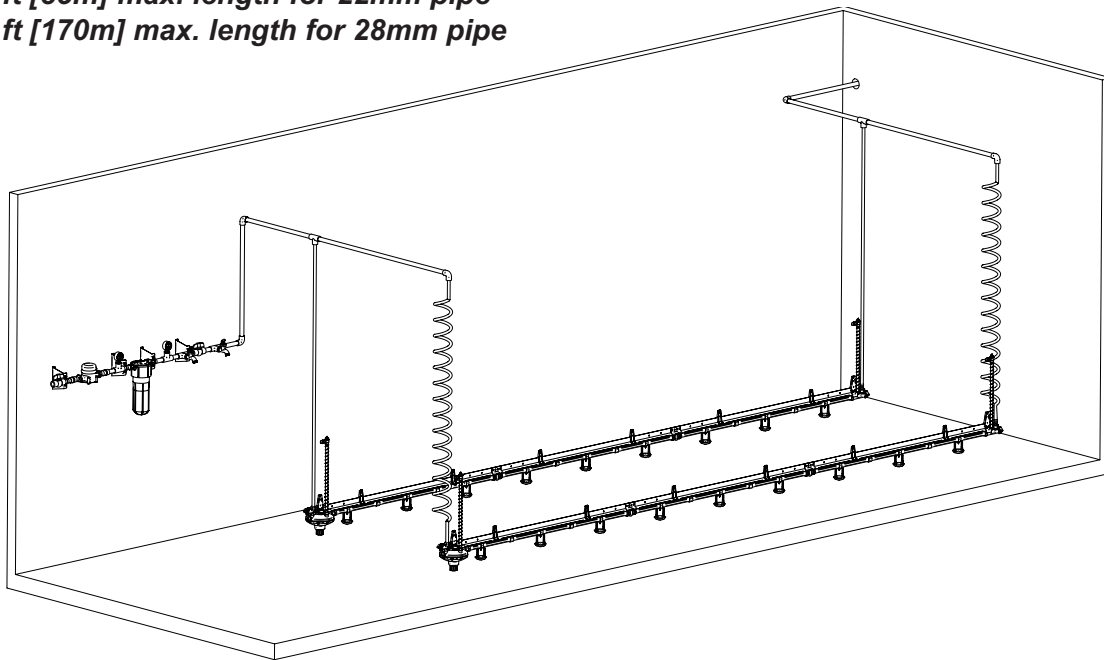

Installation Procedures

Installing the Pressure Regulator - End-House Assembly

Cutting the Pipe for Single Outlet Regulator

1. Center the pipe beneath the aluminum rail with the expansion connector facing the flush end of the house.
2. Measure 4-7/8 inches from the end of the aluminum rail and cut the pipe using a pvc cutter to make a clean cut and debur.

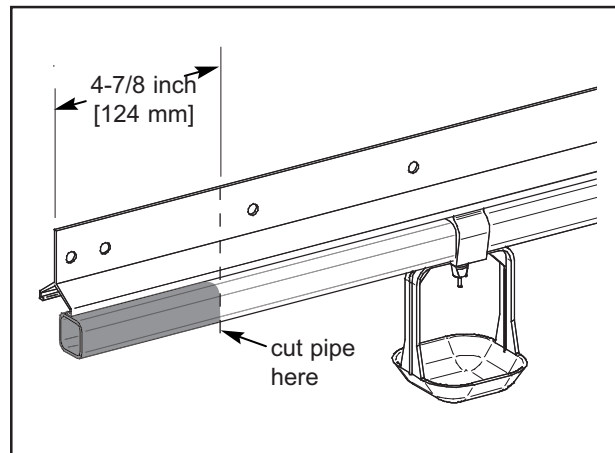

Cutting the Pipe for Single Outlet Regulator

Connecting the Pressure Regulator

1. Mount the regulator hanger onto the regulator using the 4 existing screws.
2. Apply a small amount of lubrication to the pvc pipe and insert it into the adaptor on the regulator approximately 1 inch. Vegetable oil is recommended as a safe lubricating agent.

NOTE: Do not use petroleum based lubricants on pvc.

NOTE: Do not glue this assembly. This component includes a special internal seal.

3. Insert the aluminum rail into the hanger and align the holes on the aluminum with the hanger.
4. Bolt the hanger and aluminum rail together as illustrated.

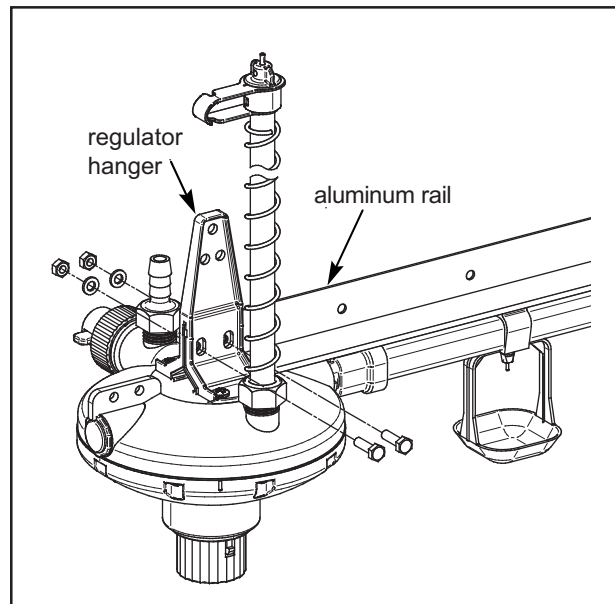

Connecting the Pressure Regulator

Installing the Pressure Regulator - Mid-House Assembly

Cutting the Pipe for Double Outlet Regulator

1. Center the pipe beneath the aluminum rail.
2. At the center of the water pipe cut 8 inches with a pvc cutter to make a clean cut and debur.

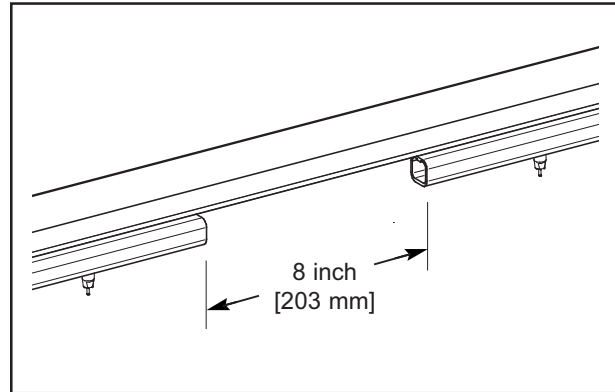

Cutting the Pipe for the Double Outlet Regulator

Connecting the Pressure Regulator

1. Apply a small amount of lubrication to the pvc pipe and insert both ends into the adaptors on the regulator approximately 1 inch. Vegetable oil is recommended as a safe lubricating agent.

NOTE: Do not use petroleum based lubricants on pvc.

NOTE: Do not glue this assembly. This component includes a special internal seal.

2. Mount the regulator hanger onto the regulator using the 4 existing screws.
3. Use the holes on the regulator hanger as guides and drill two 1/4 inch holes in the aluminum rail.
4. Bolt the hanger and aluminum rail together as illustrated.

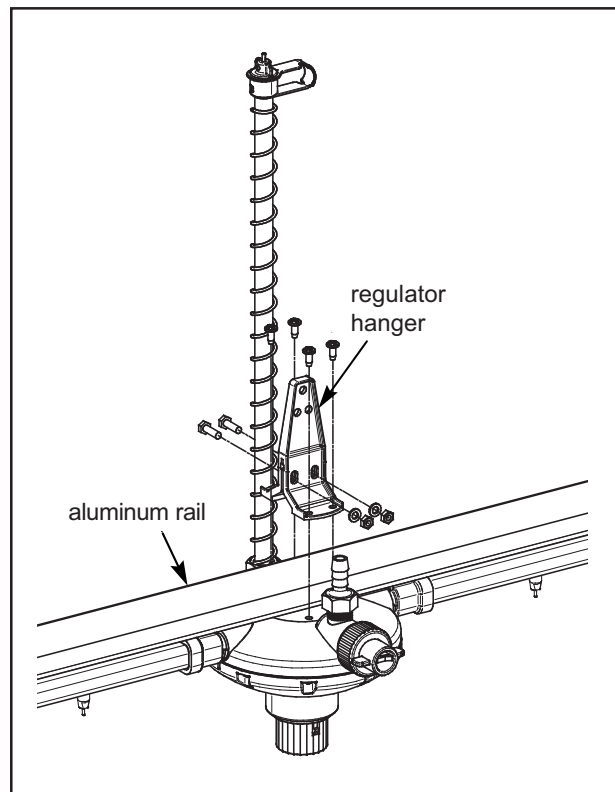

Connecting the Double Outlet Regulator

Installing the Ball Tank

Cutting the Pipe for the Ball Tank

1. Center the pipe beneath the aluminum rail with the expansion connector facing the flush end of the house.
2. Measure 1-5/8 inches from the end of the aluminum rail and cut the pipe using a pvc cutter to make a clean cut and debur.

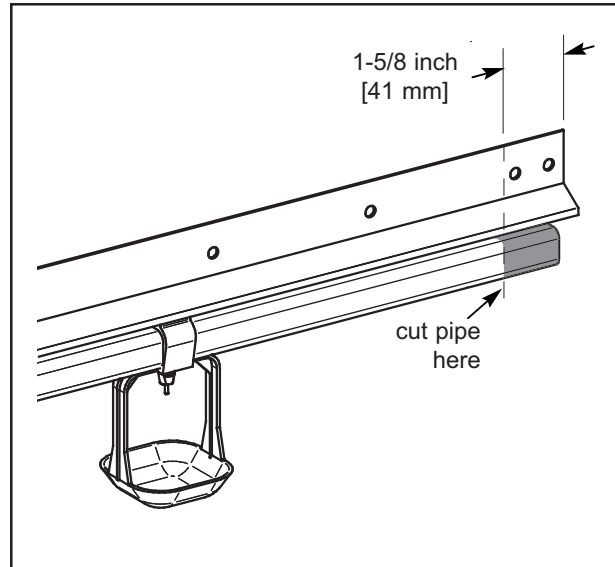

Cutting the Pipe for Ball Tank

Connecting the Ball Tank

1. Insert the pvc pipe approximately 1 inch into in the rubber connector on the base of the Ball Tank and crimp into position using the crimping tool.

NOTE: *When crimping the rings make sure to hold the crimping tool perpendicular to the ring.*

2. Insert the aluminum rail into the rail connecting bracket and align the holes on the aluminum rail.
3. Bolt the aluminum rail to the Ball Tank as illustrated.

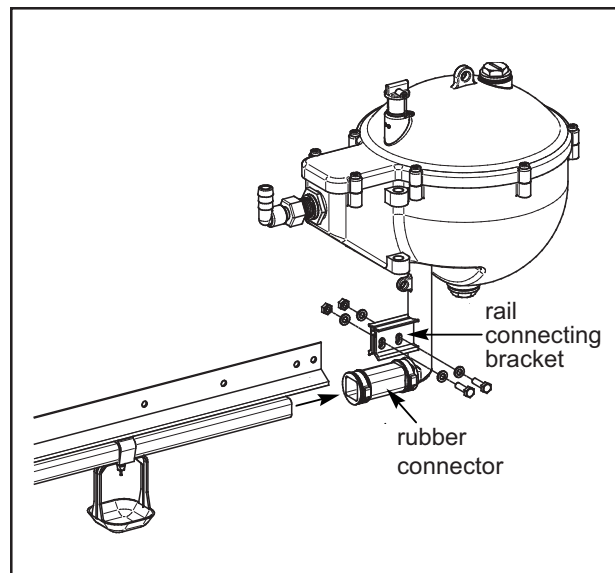

Connecting the Ball Tank

Using the Crimping Tool

1. When crimping the rings it is important to hold the crimping tool perpendicular to the ring. Illustrated are the correct and incorrect ways to crimp the rings.

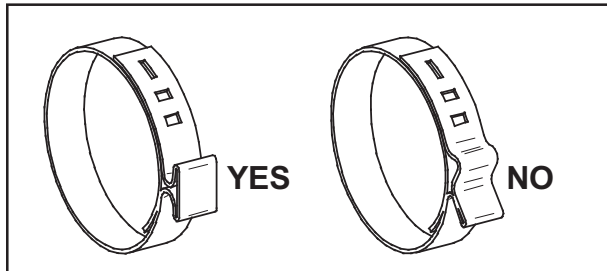

NOTE: Improper crimping of rings may cause water leaks.

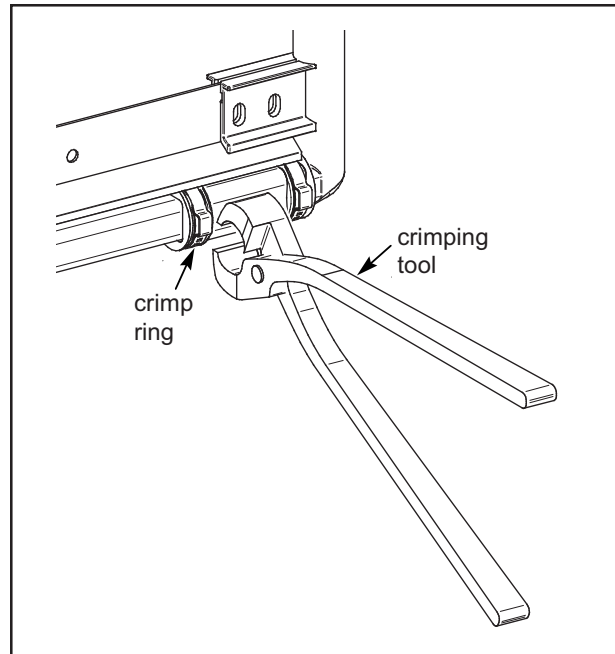

Using the Crimping Tool

Hanging Options

Suspending the System with the Three-Hole String Adjuster or the Two-Piece String Adjuster

There are two options available for suspending your watering system. Depending on how the system was purchased, one of these methods will apply. Illustrated are the correct ways to suspend the watering system utilizing the three-hole string adjuster or the two-piece string adjuster.

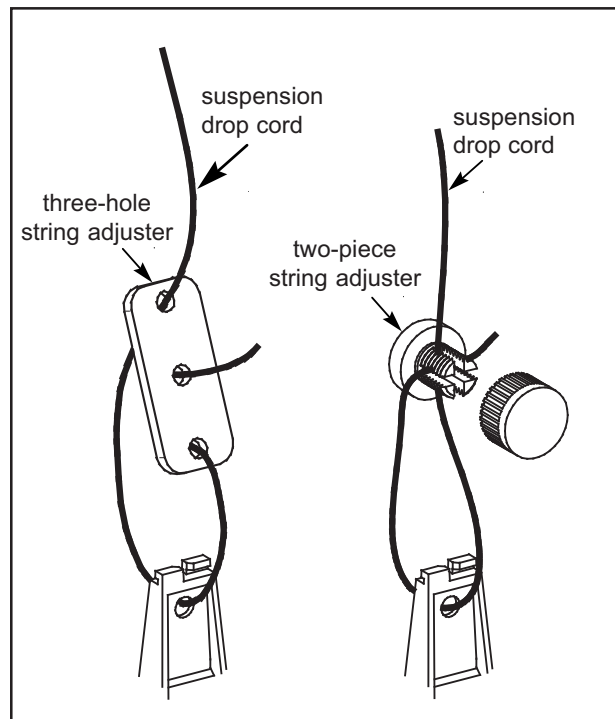

Two-Piece and Three-Hole String Adjusters

Attaching the Pressure Regulator to the Suspension Drop

1. Thread the suspension drop cord through the slots on the breather.
2. Insert the end of the cord through the three-hole string adjuster or the two-piece string adjuster and through the hanger on the pressure regulator.
3. Adjust the height to a comfortable working height (about waist high) to continue installation of the watering sections.

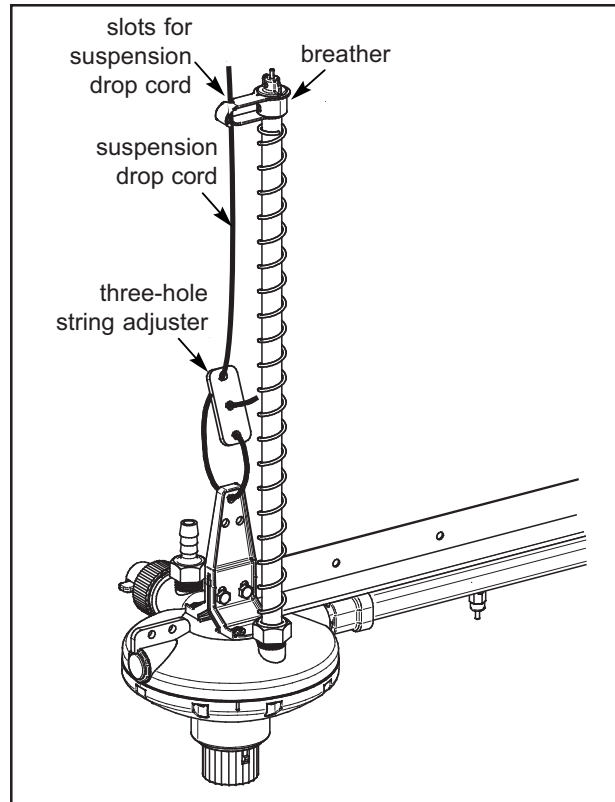

Suspending the Pressure Regulator

Attaching the Ball Tank to the Suspension Drop

1. Insert the end of the cord through the three-hole string adjuster or the two-piece string adjuster and through the suspension ring on top of the ball tank.
2. Adjust the height to a comfortable working height (about waist high) to continue installation of the watering sections.

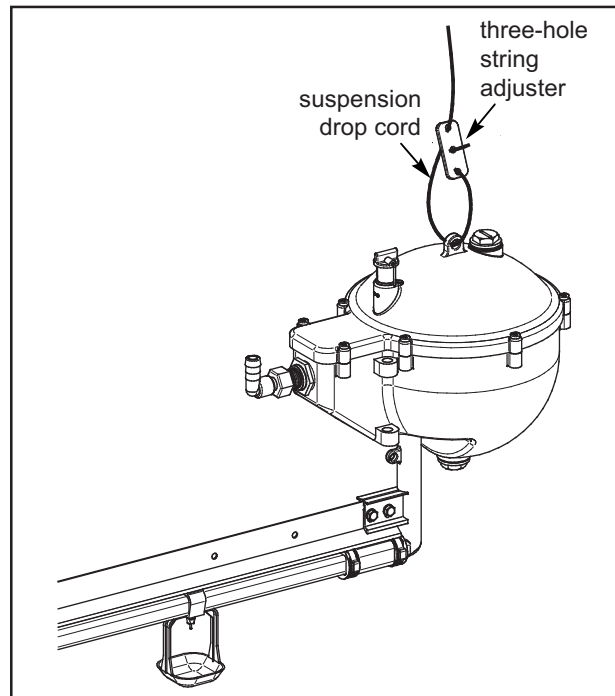

Suspending the Ball Tank

Installing the Watering Sections

Attaching the Suspension Hangers

Before proceeding determine the number of suspension hangers required for this step of the installation.

Breeders and Pullets:

Attach 5 Suspension Hangers evenly spaced along the length of the watering section.

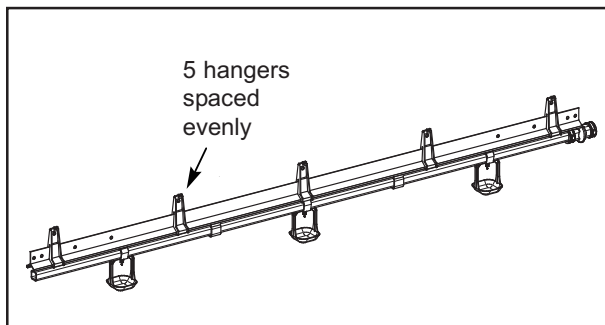

Hanger Arrangement for Pullets and Breeders

Broilers:

Attach 1 Suspension Hanger close to the end of the watering section near the expansion connector.

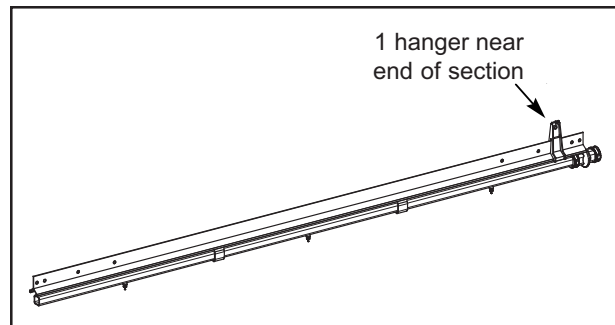

Hanger Arrangement for Broilers

Connecting the Watering Sections

The first watering section has already been connected to either the pressure regulator or the ball tank.

1. Suspend the end opposite the regulator or ball tank and set the height to waist height.
2. Insert the end of the next watering section into the expansion connector and crimp the ring.
3. Connect the aluminum rails with the metal connector as illustrated and tighten.

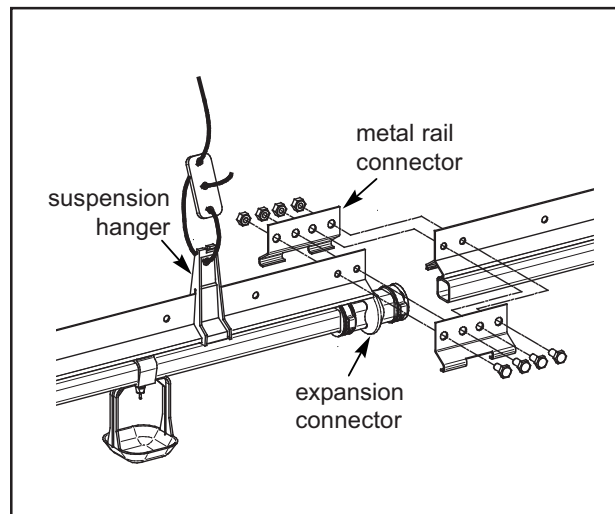

Connecting the Watering Sections

Installing the Slope Reducers

Establishing the Slope Reducer Location

Determine the exact location of the slope reducer based on the model type being used. Lubing offers 4 inch, 6 inch and 8 inch slope reducers.

Identifying the Slope Compensation Type

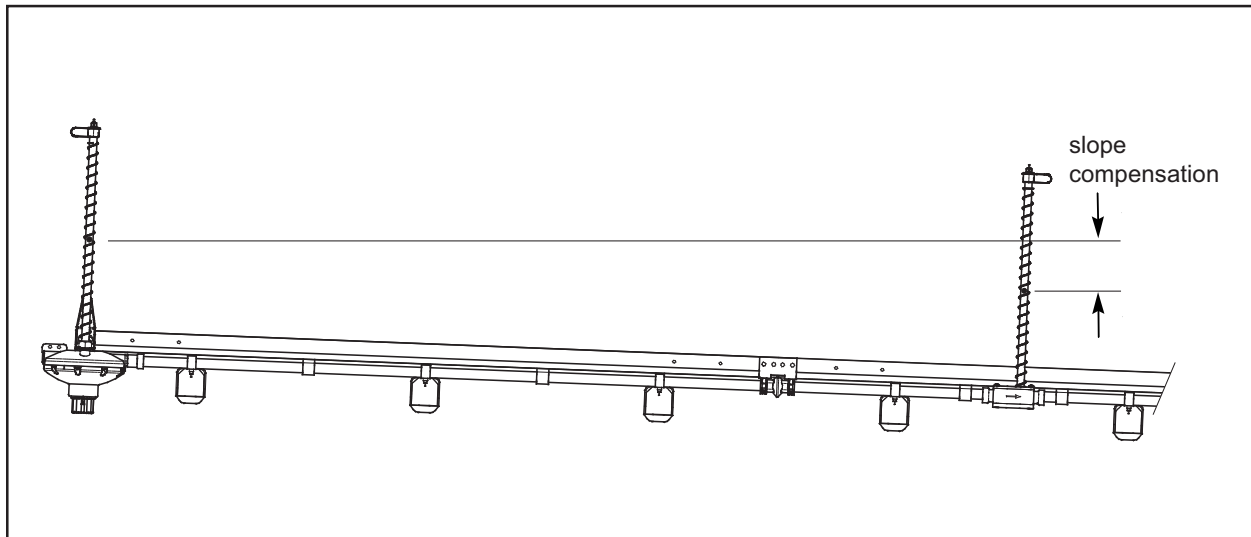
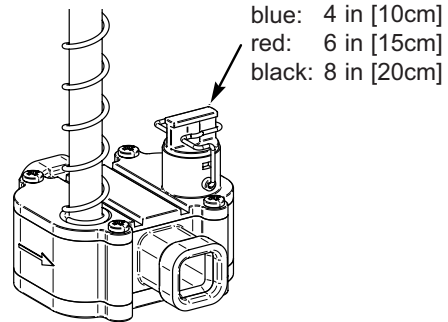

Establishing the Slope Reducer Location

Cutting the Pipe for the Slope Reducer

When the location of the slope reducer is determined cut 3-1/4 inches of pipe using a pvc cutter to make a clean cut and debur.

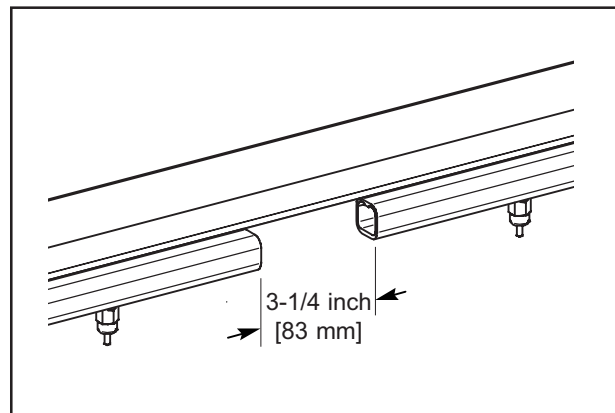

Cutting the Pipe for the Slope Reducer

Installing the Slope Reducer

1. Before installing the slope reducer make note of the arrow stamped on its side. This arrow indicates the direction of the water flow.
2. Apply a small amount of lubrication to the pvc pipe and insert both pipes into the slope reducer . Vegetable oil is recommended as a safe lubricating agent.

NOTE: Do not use petroleum based lubricants on pvc.

NOTE: Do not glue this assembly. This component includes a special internal seal.

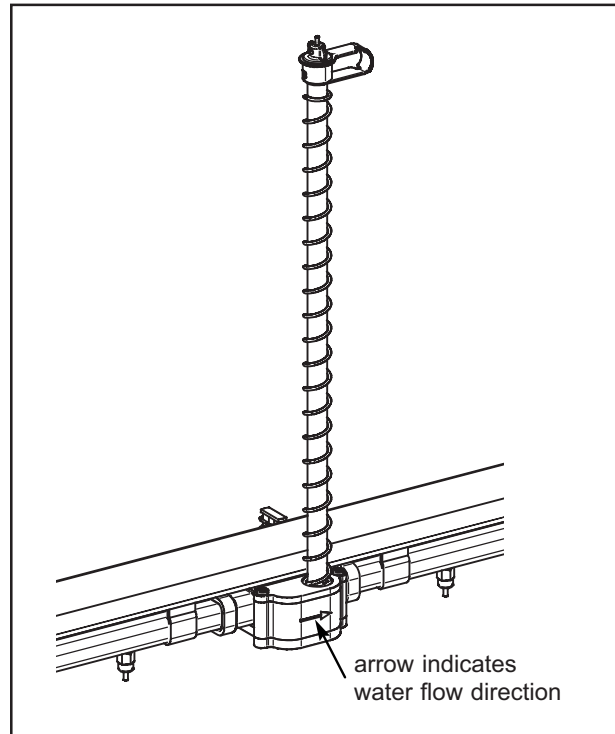

Installing the Slope Reducer

Installing the Mid-Line Shut-Off

Cutting the Pipe for the Mid-Line Shut-Off Assembly

Determine the location of the mid-line shut-off assembly and cut 15-1/2 inches of pipe with a pipe cutter to make a clean cut and debur.

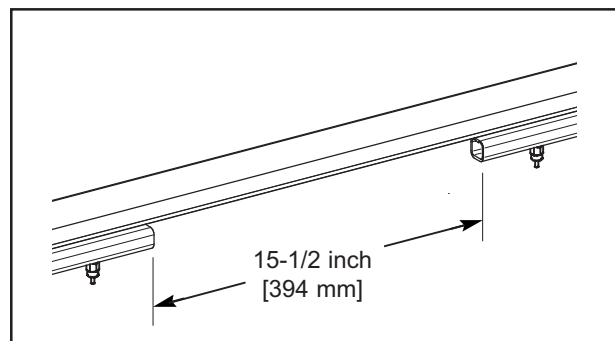

Cutting the Pipe for the Mid-Line Shut-Off Assembly

Installing the Mid-Line Shut-Off Assembly

1. Install the mid-line shut-off assembly as illustrated making sure the breather is slightly elevated to help the air escape.

NOTE: Failing to elevate the breather may cause air locks in the water line.

2. Secure the assembly by crimping the rings with the crimping tool.
3. Turn the knob on the bypass valve to open or close the water flow.

NOTE: When the handle on the bypass valve is parallel to the water line the valve is open. When the handle on the bypass valve is perpendicular to the water line the valve is closed.

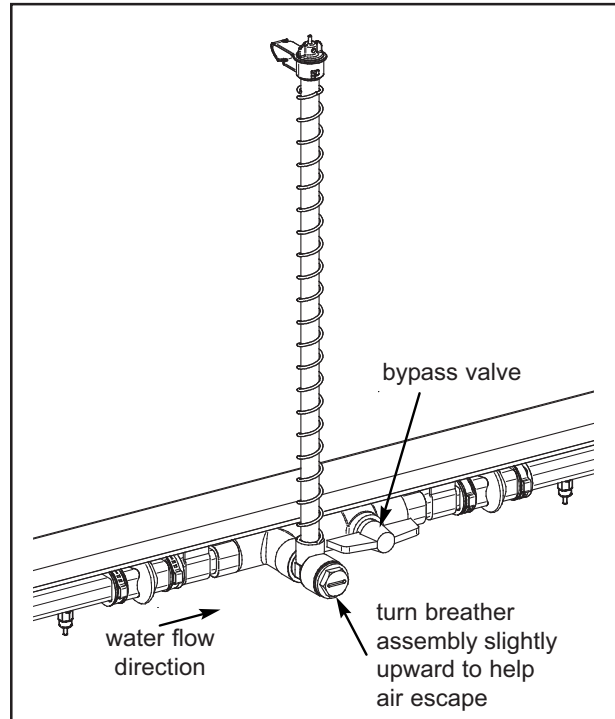

Installing the Mid-Line Shut-Off Assembly

Installing the Flush Breather

Cutting the Pipe for the Flush Breather Kit

Measure 3/4 inch from the end of the aluminum rail and cut the pipe using a pvc cutter to make a clean cut and debur.

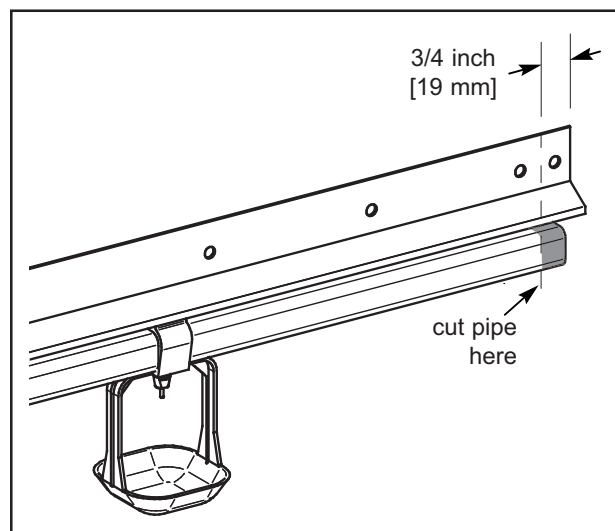

Cutting the Pipe for the Flush Breather Kit

Installing the Flush Breather Kit

1. Apply a small amount of lubrication to the pvc pipe and insert it into the flush breather kit approximately 1 inch. Vegetable oil is recommended as a safe lubricating agent.

NOTE: Do not use petroleum based lubricants on pvc.

NOTE: Do not glue this assembly. This component includes a special internal seal.

2. Insert the aluminum rail into the hanger and align the holes on the aluminum with the hanger.
4. Bolt the hanger and aluminum rail together as illustrated.

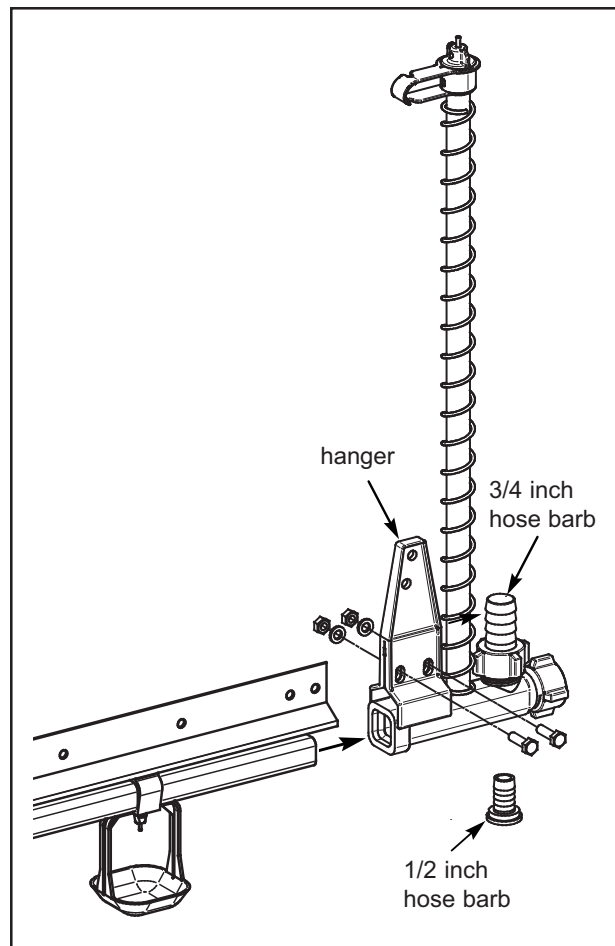

Installing the Flush Breather Kit

Installing the Shocker Wire

Connecting the Shocker Wire to the Pressure Regulator

1. Attach the end of the of the shocker wire to the three-hole string adjuster.
2. Connect one end of the spring to the regulator hanger and the other end to the three-hole string adjuster as illustrated.

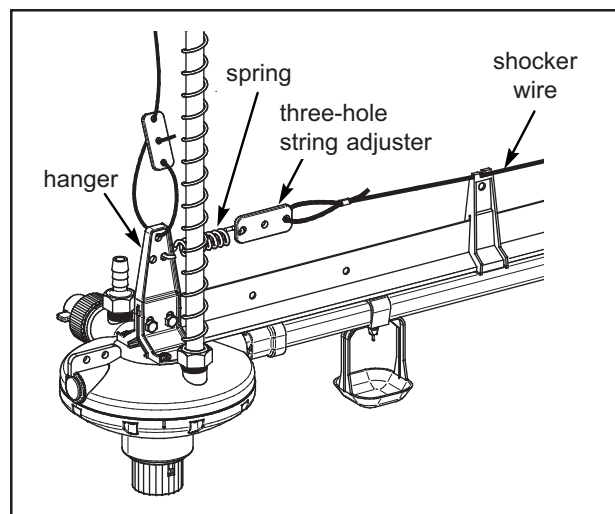

Connecting the Shocker Wire to the Regulator

Connecting the Shocker Wire to the Ball Tank

1. Attach the end of the of the shocker wire to the three-hole string adjuster.
2. Connect one end of the spring to the ball tank and the other end to the three-hole string adjuster as illustrated.

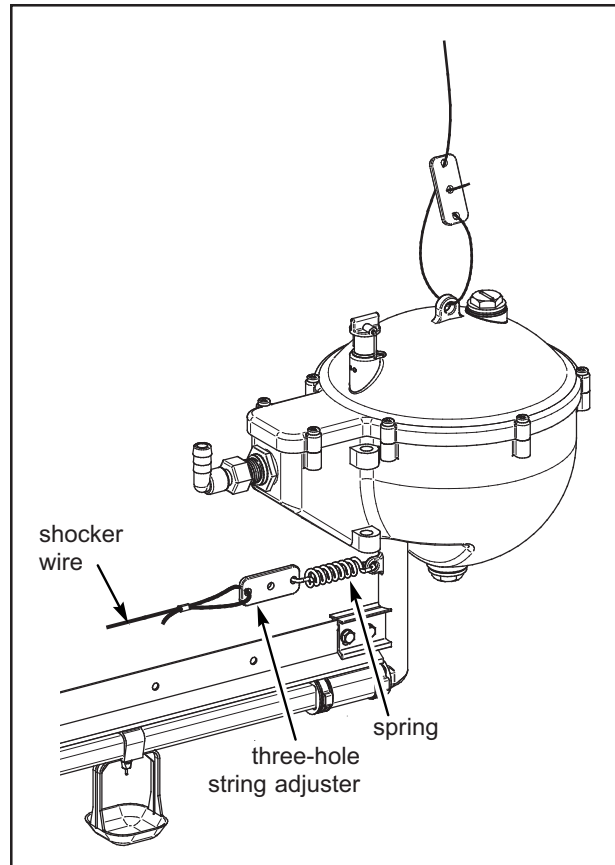

Connecting the Shocker Wire to the Ball Tank

Connecting the Shocker Wire to the Flush Breather

1. Attach one end of the spring to the flush breather hanger and the other end to three-hole string adjuster.
2. Thread the end of the shocker wire through the three-hole string adjuster and apply tension to the line.

NOTE: Be careful not to stretch the springs beyond twice their original length.

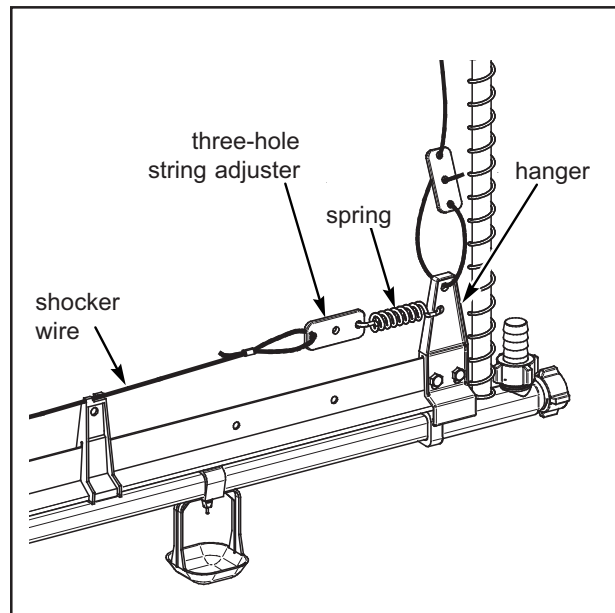

Connecting the Shocker Wire to the Flush Breather

Installing the Water Panel

Mounting the Water Panel

Install the water panel to the wall using the mounting brackets provided.

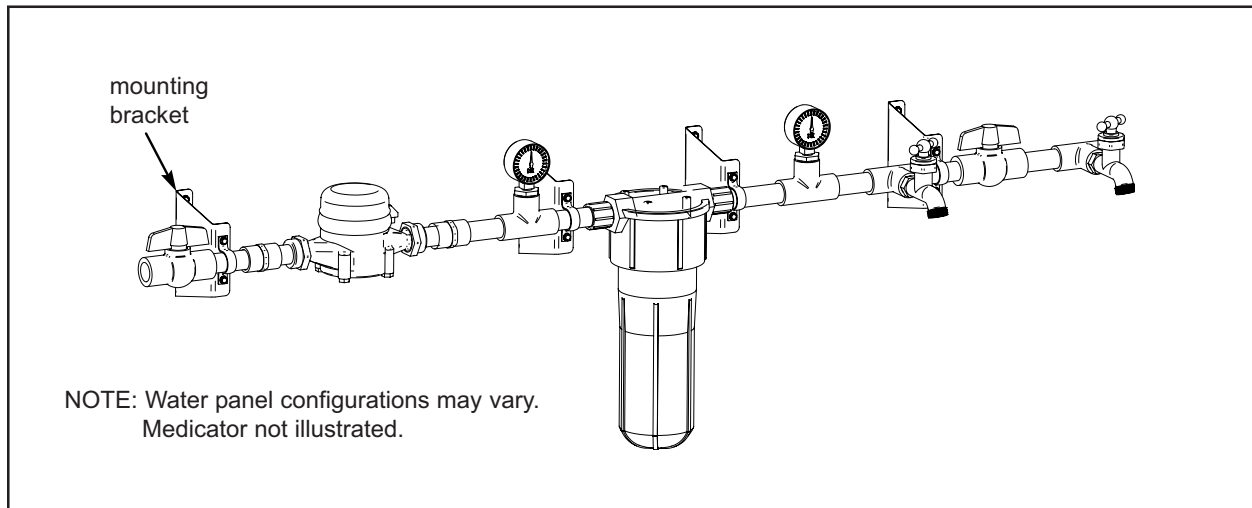

Mounting the Water Panel

Installing the Header Kit

Connecting the Header Kit to the Regulator or Ball Tank

1. Using the appropriate pvc components assemble and glue the header kit leading from the water panel to the regulators or ball tanks.
2. Make sure that the "T" drop is directly above the water entry point on the regulator or ball tank.

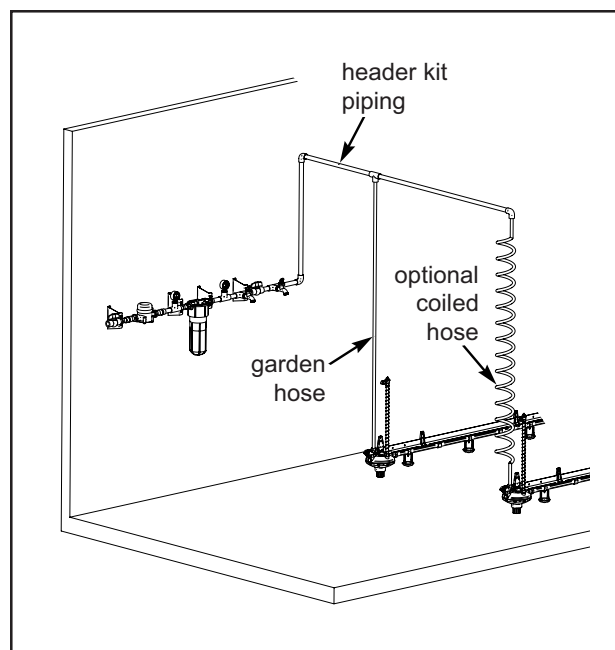

Overall View of Header Kit Installation

Installing the Flush Drain Kit

Connecting the Flush Drain Kit

1. Using the appropriate pvc components assemble and glue the flush drain kit above the flush breathers.
2. Make sure that the "T" drop is directly above each flush breather.
3. Extend one end of the flush drain kit outside the building in order to expell the flushed water outside.

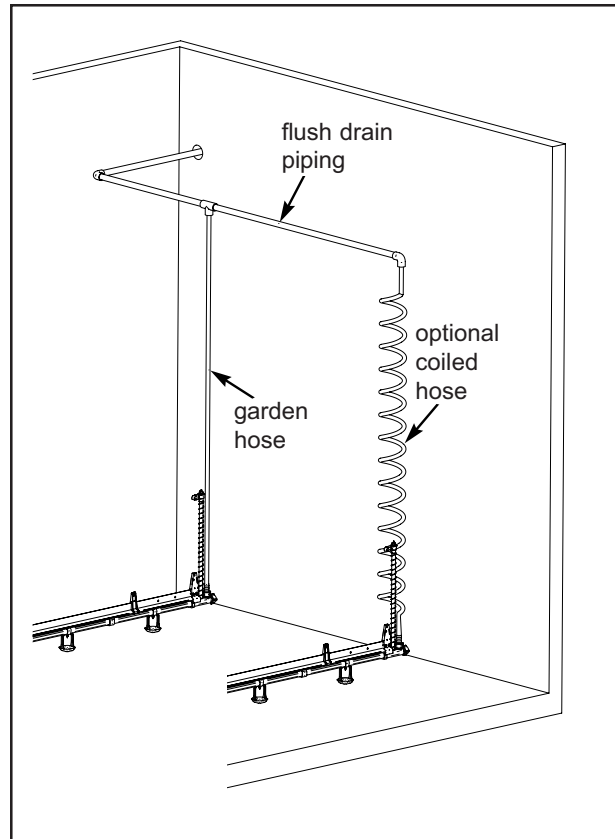

Overall View of Flush Drain Kit Installation

Installing the Optional Check-Valve Kit

Connecting the Check-Valve to the Flush Breather Kit

Assemble the check-valve kit with teflon tape and install the assembly onto the flush breather. Make sure the arrow on the check-valve is facing upward.

Illustrated are assemblies for 3/4 inch and 1/2 inch hoses.

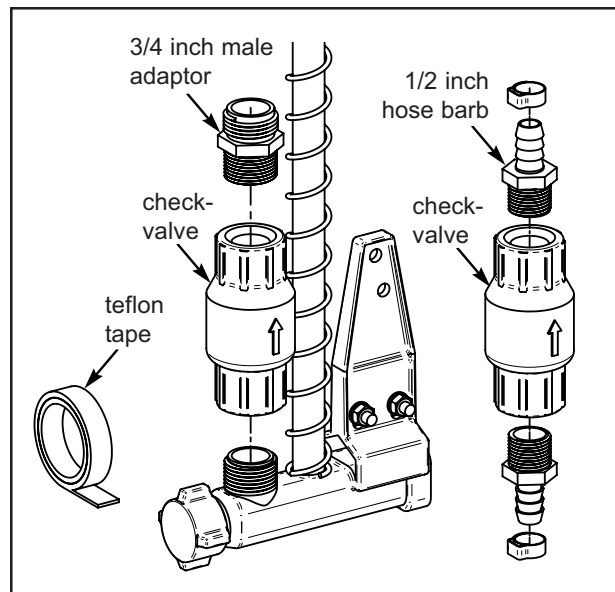

Installing the Optional Check-Valve

Post Installation Procedures

When the installation of the system is completed:

1. Adjust the water lines making sure they are level and that there are no high and low spots.
2. Check to make sure that all of the connections between watering sections have been properly crimped.
3. Check to make sure that all nuts and bolts have been properly tightened.
4. Check to make sure that all hoses have been properly clamped.
5. Check to make sure that the filter is in the water filter shell.
6. Apply water to the entire system and check for any leaks.
7. Flush the water lines for approximately 10 minutes to remove potential debris and air from the system.



CAUTION: When cleaning the water lines with chlorine do not exceed 4 ppm. High levels of chlorine can cause damage to the watering system.

Please refer to our watering and chemical reference guide for further details.

LUBING SYSTEMS, L.P. LIMITED PRODUCT WARRANTY

LIMITED WARRANTY

Each new product provided by Lubing Systems, L.P. (each "Product") is warranted to be free from defects in material or workmanship for one (1) year from date of purchase by or for the original purchaser.

ELIGIBILITY FOR LIMITED WARRANTY

In order to be eligible for coverage under this Limited Warranty, each of the following conditions must be satisfied:

1. The Product must be installed and operated in accordance with the written instructions published by the Manufacturer with respect to the product; and
2. The Product must be purchased from and installed by an authorized distributor and/or certified representative of Lubing Systems, L.P.

SOLE REMEDY

In the event of a covered Warranty claim, Lubing Systems, L.P. will, as the sole remedy and measure of damages, at its option and in its sole discretion, repair or replace the covered Product free of charge, F.O.B. its plant in Cleveland Tennessee. Labor and delivery costs associated with the replacement or repair of the covered Product are not included in or covered by the Warranty.

EXCLUSIONS

1. Malfunctions, failures, or breakage caused by misuse, abuse, negligence, alteration, accident, chemicals or minerals in the water, poor quality water, lack of sufficient water, lack of proper maintenance, electrical power surges, interruptions in power, acts of God, acts of war, riot, terrorism, or civil disobedience shall not be considered defects under the Warranty, and are excluded from coverage.
2. Alteration of the Product from the manufacturer's original configuration, and the installation of additional or replacement components other than original equipment provided and installed by the manufacturer or Lubing Systems, L.P. shall not be considered defects under the Warranty, and are excluded from coverage.
3. Use of the Product other than in accordance with the manufacturer's operational instructions and guidelines shall not be considered a defect under the Warranty, and any claims resulting from or attributable to such use are excluded from coverage.
4. The Warranty does not extend to claims made by persons other than the original consumer purchaser, and are excluded from coverage.

LIMITATION OF WARRANTY

1. EXCEPT AS PROVIDED ABOVE, LUBING SYSTEMS, L.P. MAKES NO WARRANTIES OR CLAIMS OF ANY KIND WITH RESPECT TO THE PRODUCTS. LUBING SYSTEMS, L.P. HEREBY SPECIFICALLY DISCLAIMS ANY IMPLIED WARRANTY OR CONDITION, WHETHER STATUTORY OR OTHERWISE, INCLUDING ANY WARRANTY OF MERCHANTABILITY OR FITNESS FOR A PARTICULAR PURPOSE.

2. LUBING SYSTEMS, L.P. IS NOT RESPONSIBLE FOR LOSS OF TIME OR PROFITS, INCREASED COSTS OF LABOR, INCONVENIENCE, LOSS OF USE OF PRODUCT, LOST SALES OR ORDERS, OR ANY OTHER CONSEQUENTIAL, INCIDENTAL OR INDIRECT DAMAGES.

3. THIS LIMITED WARRANTY IS ONLY APPLICABLE IN THE UNITED STATES AND CANADA.

4. THIS LIMITED WARRANTY CONSTITUTES THE ENTIRE WARRANTY GIVEN BY LUBING SYSTEMS, L.P. WITH RESPECT TO THE PRODUCTS, AND LUBING SYSTEMS, L.P.'S COMPLETE OBLIGATION WITH RESPECT TO THE PRODUCTS IS STATED IN THIS LIMITED WARRANTY. NO PERSON OR ENTITY HAS THE AUTHORITY TO IMPLY, SUGGEST, AGREE, REPRESENT, WARRANT, OR PROMISE CONTRARY TO THE TERMS OF THIS LIMITED WARRANTY.

WARRANTY CLAIM PROCEDURE

In order to present a claim for coverage under this Limited Warranty, please contact Lubing Systems, L.P. at:

LUBING Systems, LP
135 Corporate Drive, SW
Cleveland, TN 37311

423-709-1000 tel
423-709-1001 fax
866-289-3237 toll-free fax

When calling, you will be requested to provide the following information:

1. Your name;
2. Your address;
3. Your phone number(s);
4. The date of the Product malfunction or failure;
5. The Product identifier number;
6. Proof of the date of purchase of the covered Products;
7. The invoice number or bill of lading from the delivery of the covered Products; and
8. The nature of the Product defect, malfunction, or failure.

GENERAL TERMS AND CONDITIONS

Lubing Systems, L.P. ("Lubing")

Lubing accepts purchase orders, offers and counter-offers from Buyer, and contracts with Buyer, only under the terms and conditions specified herein. Buyer's terms and conditions in relation to this transaction, except price and quantity, are each specifically objected to by Lubing and shall not apply to this transaction, unless subsequently agreed in writing signed by an authorized representative of Lubing.

I. Price and Taxes

1. Unless otherwise specifically agreed in writing signed by an authorized representative of Lubing, prices for products ("Products") are as stated Lubing's Complete Parts List, found on Lubing's website (www.lubingusa.com), and whether for domestic or export shipment, is F.O.B. point of shipment.
2. For additional requirements agreed by Lubing after agreeing to the price, Buyer shall pay Lubing's increases in time, cost or expense for any such change, including Product characteristics, configurations, form or material, quality levels, special testing, inspection or measurement, special drawings or any other such change or additional requirement.
3. Any present or future taxes which Lubing may be required to pay or collect with respect to the sale, purchase, delivery, storage, use, consumption or transportation of the Products, shall be paid by the Buyer.
4. Payment terms for U. S. transactions are net thirty (30) days from the date of shipment of Products to Buyer, unless specifically agreed in writing otherwise. Payment for export shipments must be by advance payment or by irrevocable letter of credit payable at site in local currency at par, issued and confirmed by banks acceptable to Lubing, unless other arrangements are specifically agreed in writing.

II. Delivery

1. Products shall be packaged by Lubing's standard method and shipped to the agreed destination via commercial freight carrier as selected by Lubing.
2. Products shall be shipped by Lubing when prepared in the ordinary course of its business. Dates for shipment specified in this contract are targets, but not commitments, of Lubing unless agreed upon in writing by Lubing.
3. At Buyer's cost and as may be agreeable to Lubing, Buyer may pickup Products at Lubing's facility or specify other means of delivery acceptable to Lubing.

III. Quality and Warranty

1. Lubing warrants Products to be free from defect in material and workmanship only as provided in Lubing's General Product Warranty as found on Lubing's website (www.lubingusa.com), as may be amended, modified, or replaced from time to time.
2. In addition, Lubing warrants Products included on Nipple Selection catalog to be free from defect in material and workmanship only as provided in Lubing's Nipple Warranty as found on Lubing's website (www.lubingusa.com), as may be amended, modified, or replaced from time to time.
3. The foregoing warranties are only valid for Products defective at the time of shipment or for defect in installation performed by Lubing personnel.
4. No warranty shall extend to Products which have been subjected after shipment by Lubing to misuse, neglect, accident, improper installation (other than by Lubing personnel), or which has been repaired or altered other than by Lubing personnel.
5. **THE FOREGOING WARRANTIES ARE IN LIEU OF ALL OTHER WARRANTIES AND REMEDIES FOR PERFORMANCE AND CONDITION OF THE PRODUCTS AND INSTALLATION, AND EXCEPTING A COVENANT FOR GOOD TITLE TO THE PRODUCTS, LUBING MAKES NO OTHER WARRANTY, EXPRESSED OR IMPLIED, INCLUDING WARRANTIES OF MERCHANTABILITY, OR OF FITNESS FOR USE FOR A PARTICULAR PURPOSE.**

IV. Claims

1. On notice of warranted defect, Lubing may conduct an on-site investigation.
2. Buyer shall assist in all reasonable ways with Lubing's investigation of claims.
3. All claims of warranty coverage shall be handled in accordance with Lubing's General Product Warranty as found on Lubing's website (www.lubingusa.com), as may be amended, modified, or replaced from time to time.

V. Limitation on Liability

1. The parties agree that the exclusive remedy of Lubing for any claims related to Products installation, performance, or warranty shall be as provided in Lubing's General Product Warranty as found on Lubing's website (www.lubingusa.com), as may be amended, modified, or replaced from time to time.
2. Lubing shall not be liable in any event for any other expense incurred by Buyer or others, nor for any special, consequential, liquidated, incidental, punitive, or other damages, losses or penalties suffered by Buyer or anyone else with respect to the Products delivered or offered by Lubing, or Lubing's Product installation, including without limit, loss of profit, production, or use, or damage to other goods or property.

VI. Late Payment and Security Interest

1. Buyer grants to Lubing a purchase money security interest in all Products purchased from Lubing until all amounts owed to Lubing from Buyer are paid, specifically authorizes Lubing to file such UCC financing statements or other documents as may be required to perfect such security interest, and shall execute any documents necessary for Lubing to perfect such security interest.

2. If at any time any payment due to be paid by Buyer to Lubing is past due, Lubing may reschedule, suspend or cancel any pending deliveries to Buyer. If Buyer voluntarily or involuntarily becomes a debtor in any bankruptcy, insolvency, workout or similar process, then thereafter payment for Products shall be by cash to Lubing sixty (60) days in advance of delivery to Buyer; Lubing may suspend all work towards completion of Products to be delivered until such payment is made, and the date for delivery shall be on or before the sixtieth (60th) day following such payment.
3. Buyer grants to Lubing permission to enter Buyer's premises and to obtain possession of any Products with respect to which payment is not made in accordance herewith.
4. Amounts owed to Lubing from Buyer shall include promises to pay and other commitments to pay which may be in substitution of accounts or other obligations.

VII. Cancellation by Buyer

1. For the period Lubing delays or postpones shipment at Buyer's request or for overdue accounts, Buyer shall pay a delay charge on Lubing's committed costs at an annual rate of twelve percent (12%).
2. When Lubing has received from Buyer adequate notice in writing prior to commencement of manufacture of the Products, Lubing shall rescind a standing purchase order, but Buyer shall be responsible for costs incurred by Lubing in preparation of manufacture, including without limitation, cost of raw materials, labor, engineering, overhead and selling and other expenses.

VIII. Termination and Modification

1. Termination of any purchase order requires the written consent of both parties unless otherwise specifically provided. Lubing may terminate a purchase order unilaterally for failure to pay when due, and also if Buyer has not made reasonable progress in correcting another material breach of any agreement between Lubing and Buyer within thirty (30) days after notice thereof.
2. Except for payment of accounts when due, neither party shall be liable for loss, damage, detention or delay resulting from any cause whatsoever beyond its reasonable control ("Force Majeure"). The party affected by such Force Majeure promptly shall notify the other party. If performance, other than payment when due, is delayed by Force Majeure for more than thirty (30) days, then either party may terminate this Contract on notice to the other.
3. In the event of termination of a purchase order as provided in subsections 1 or 2, above, Buyer shall make payment to Lubing of the full price for the Products less all net savings of Lubing, if any, as determined by Lubing to result from such termination.
4. In the event of termination of a purchase order other than as provided in subsections 1 and 2 above, Buyer shall be required to pay to Lubing the full purchase price for the Products ordered.

IX. Disputes and Interpretation

1. Any dispute between the parties arising out of this Agreement shall be determined by binding arbitration under the rules of the American Arbitration Association ("AAA"). The arbitration shall be conducted in Atlanta, Georgia, by a single arbitrator mutually acceptable to the parties, or, in the event the parties are unable to agree upon a single arbitrator, by a single arbitrator appointed by the Atlanta, Georgia, office of such association. The cost of the arbitrator and of AAA shall be divided and borne equally by the parties.
2. The law of the State of Tennessee shall govern the relationship among Lubing and Buyer. These Terms and Conditions are part of any other documents to which these Terms and Conditions are attached or by which these Terms and Conditions are referenced, and such documents are incorporated herein by this reference and, except as are specifically objected to by Lubing or by these Terms and Conditions, are a part of the entire agreement among the parties.
3. No waiver by one party of any rights which that party may have shall be considered a waiver of subsequent assertion of such rights, except in accordance with the terms of a written waiver. Any provision of these Terms and Conditions determined to be unenforceable shall be interpreted in the most limited extent possible so as not to render the remainder of the provisions of these Terms and Conditions, or any agreement of which these Terms and Conditions are a part, unenforceable.

Lubing Systems L.P. Returned Goods Policy

December 17, 2005

Returns. Except for Lubing's Products that are defective at the time of delivery to Distributor, Lubing shall not be obligated to accept returns of any of Lubing's Products. Any permitted returns shall be handled in accordance with Lubing's Returned Good Policy, as may be amended from time to time.

1. Distributor shall examine each Product purchased and notify Lubing in writing of any defective Product within five (5) days following Distributor's (or Distributor's customer's) receipt of such Product. Products shall be deemed accepted unless Lubing has been notified of such defect within such five (5) day period.

2. Any item being returned to Lubing must be accompanied by a Returned Goods Authorization number (an "RGA"), clearly visible on the outside of the return packaging. ***Any item received by Lubing without a clearly visible RGA will be returned to sender at sender's expense.*** Distributor (or distributor's customer) should contact Lubing at (866) 289-3237 to obtain an RGA, and should have the following information available:

- (a) Name of party billed
- (b) Shipment destination
- (c) Name of grower and integrator (if applicable)
- (d) Status of invoice payment
- (e) Exact quantity and description of items for return
- (f) Reason for return and condition of returned Product

All returns should be shipped freight prepaid.

3. If Lubing issues replacement Product prior to Lubing's receipt of the returned Product, then Lubing will issue credit against the invoice for replacement Product upon Lubing's receipt of the returned Product.

4. Lubing reserves the right to impose a restocking charge of twenty- percent (20%) of the purchase price of any returned Product.

LUBING SYSTEMS, LP
CHANGE ORDER POLICY

Lubing constantly strives to meet our customers' needs. One of the ways this is achieved is through effective production planning. In order to plan production efficiently, Lubing Systems must be able to rely on the accuracy and stability of orders, including exact parts, quantities and shipment dates, to efficiently manage production and provide customers with the best and most efficient service.

Lubing recognizes that needs can change, however, and will attempt to accommodate modifications requested by customers according to the following policies:

- Any customer requesting a change to an accepted purchase order is required to notify Lubing in writing of such change, including changes regarding product type, quantity and/or shipment dates, not later than two (2) weeks prior to the scheduled shipment date.
- Customers are required to submit all change order notifications via fax to (866) 289-3237, or via email to tjenkins@lubingusa.com.
- Lubing will attempt to accommodate requested changes, but cannot guarantee the original requested ship date if the customer requests changes in product type or quantity.
- Unless otherwise agreed in writing signed by an authorized Lubing representative, any change to or cancellation of an accepted purchase order received by Lubing s upon fewer than two (2) weeks' notice prior to the scheduled shipment date will result in a change order fee equal to equal to the purchase price of the subject Products.

LUBING

A Tradition of Innovation.

Contact your local Lubing distributor or representative for additional information regarding Lubing products.

All technical content in this instruction is subject to change.

LUBING Systems, L.P.

135 Corporate Drive, SW
Cleveland, TN 37311 • USA

423 709.1000 tel
866 289.3237 toll-free fax
info@lubingusa.com
www.lubingusa.com

Printed in the U.S.A.