

LUBING

STEEP CONVEYOR
EGG TRANSPORT UP TO 60°

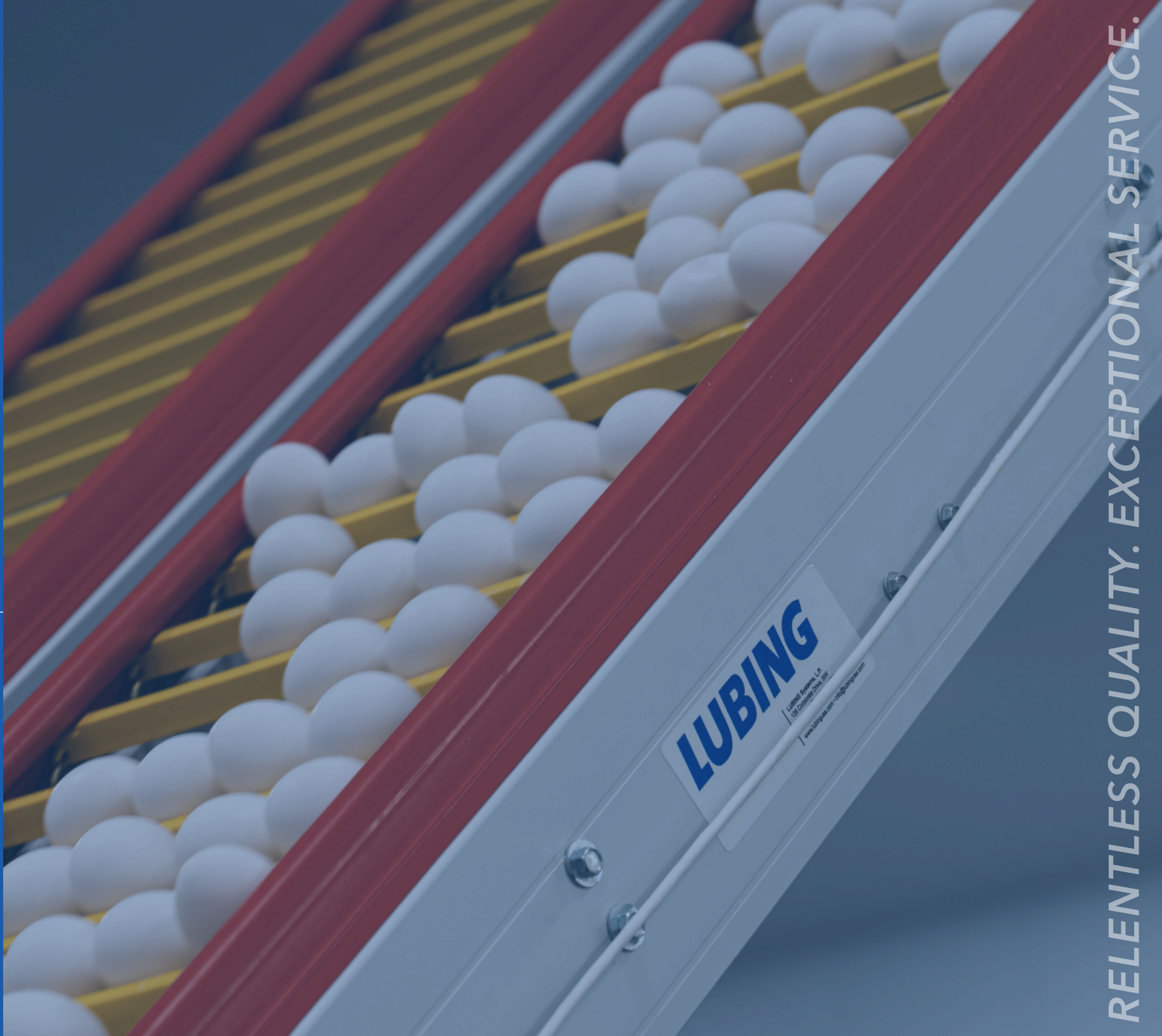

LUBING
LUBING Systems, L.P.
150 Corporate Park, SW
www.lubing.com | info@lubing.com

RELENTLESS QUALITY. EXCEPTIONAL SERVICE.

OVERVIEW

The steep conveyor makes it possible to overcome large elevation differences with limited horizontal space. The steep conveyor is an ideal solution when elevation angles exceed 28°. The conveyor chain with plastic tab elements is the core of the conveyor and enables inclines or declines of up to 60°.

All components have been derived from our curve conveyor system and have been specially developed to meet the needs of farms with floor or aviary housing. The well-known and proven standard elements such as drives, bends, pivoting units, and intermediate drives for large conveyor sections can all be integrated without transfer points.

FEATURES AND BENEFITS

- System supports gradients or inclines for up to 60°
- Designed for gentle egg handling throughout the length of the system
- Compatible with all LUBING curved conveyor elements
- Modular in construction and engineered specific to your farm
- All sections and components arrive at your farm pre-assembled
- The replaceable tab elements made of high-quality plastic ensure the safe position of all egg sizes in the transition from level to slope

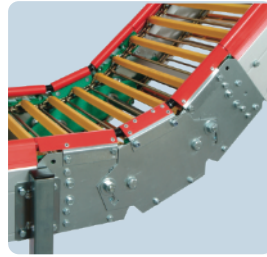

Pivoting Unit Incline

- Adjustable angle up to 50° gradient
- Flexible and continuously adjustable side plates



Slope Segment Ascent 60°

- Fixed preset unit for 60° slope
- Tab elements required (will reduce egg flow by approximately 50%)



Pivoting Unit Decline

- Adjustable angle up to 50° slope
- Flexible and continuously adjustable side plates



Trampoline Transfer

- Special net for transfer into the steep conveyor chain
- Flexible, soft transfer for maximum gentle egg handling

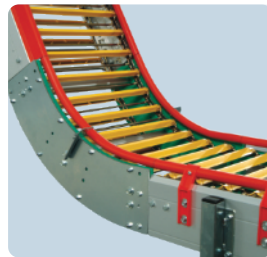

Slope Segment Descend 60°

- Fixed preset unit for 60° gradient
- Tab elements required (will reduce egg flow by approximately 50%)

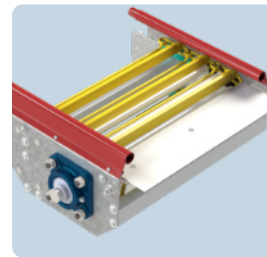

Idler Unit

- Transfer eggs on or off
- Includes input wheel
- Optional stainless steel construction available



Bends

- Flexible curve guidance
- All angles from 5° to 180° possible

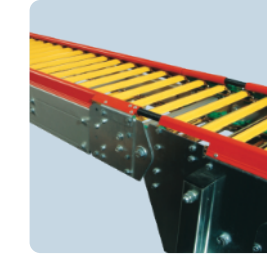

Connecting Parts

- Available in 1-meter, 2-meter and 3-meter lengths
- Can be customized to suit your needs

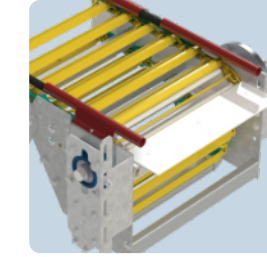

Mini Drives

- Mini drive utilizes ½ HP motor
- Integrated take-up element for correct chain tensioning
- Includes transfer plate

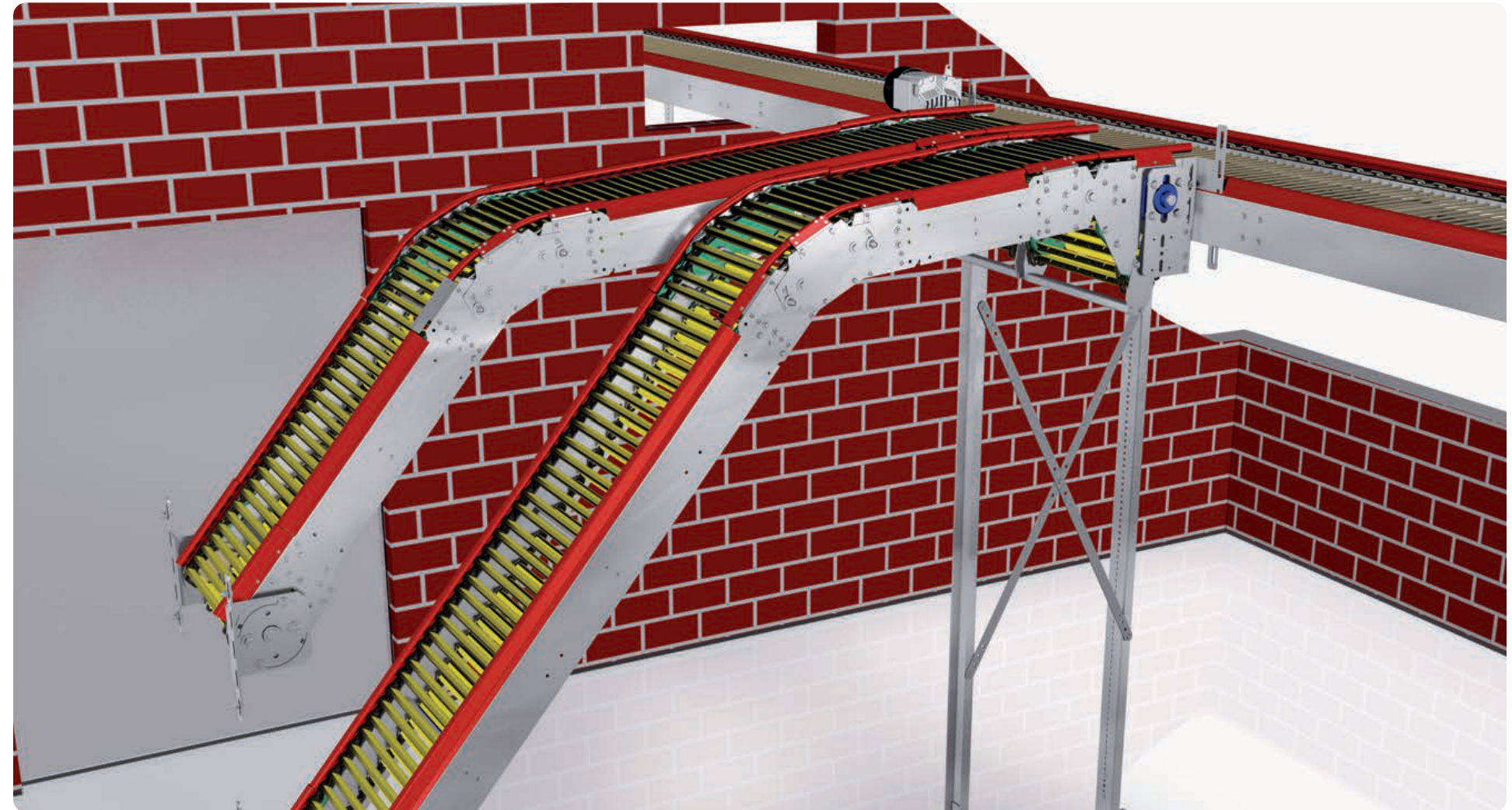

SYSTEM CAPACITIES

At a speed of 25 feet per minute, with adequate space for safe loading:

	Width	Capacity
Type 350	14 inches	62.5 cph (22,500 eph)
Type 500	20 inches	95 cph (34,200 eph)

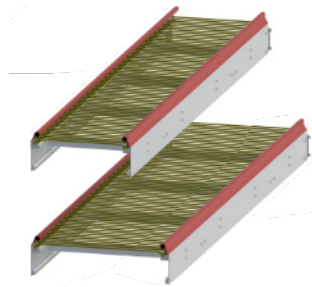

LUBING certified installation services are available upon request.

Ascend and descend up to max. 60°

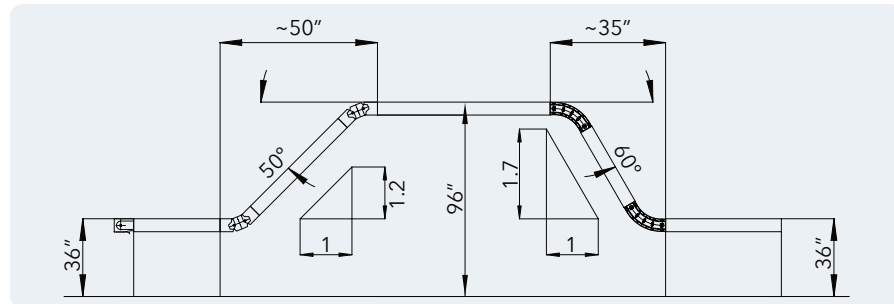

Pivoting unit, continuously adjustable up to 50°

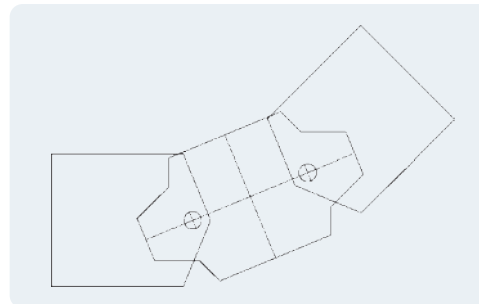

Fixed incline segments 60°

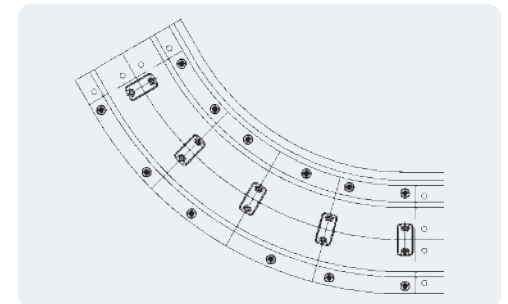

Josh Bandy
 Conveyor Sales Manager
 423-716-0181
 jbandy@lubingusa.com

