

## SIGHT TUBE AND BREATHER UNIT

SPRINGLESS SIGHT TUBE AND BREATHER UNIT

ALL LUBING BREATHER UNITS ARE NOW SUPPLIED WITH NO OUTER SPRINGS AND OFFER IMPROVED FEATURES:

- Chemically resistant clear tubing with shape memory
- Easy cleaning
- Optimum visibility of water column indicating ball
- Improved sealing capabilities

### POLYURETHANE SIGHT TUBE:

- High elasticity material with no deformation offers spring-like properties to return the tube to its original vertical shape
- Material is resistant to chemical exposure and staining, keeping the inside surface clean and transparent
- Elimination of outer spring makes cleaning outside of tube easier and less tedious

### STAINLESS STEEL CRIMP RING:

- Provides added security

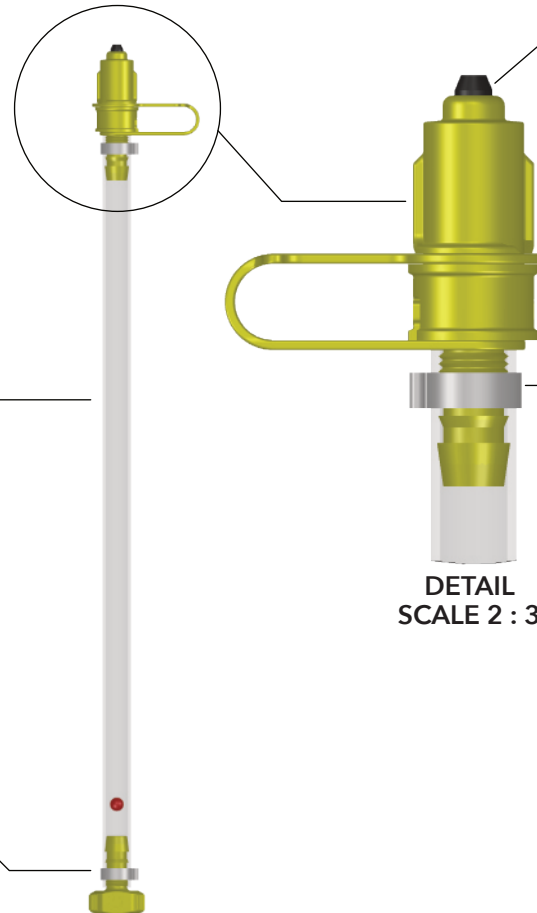

### IMPROVED BREATHER SEAL:

- Made from flexible PVC for high chemical resistance
- Sealing design allows valve to remain open for airflow and close at water onset to minimize water egress into environment

### STAINLESS STEEL CRIMP RING

- Provides added security
- Prevents breather cap from rotating

BREATHER UNITS WITH SPRINGS HAVE BEEN DISCONTINUED, BUT WILL KEEP THE SAME PART NUMBERS

PART#	PART DESCRIPTION
3317-00	BREATHER UNIT 450MM
3317-6-00	BREATHER UNIT 650MM
3317-9-00	BREATHER UNIT 950MM