

LUBING

ACCUMULATOR TABLE
GENTLE EGG TRANSFER ACCUMULATOR TABLE

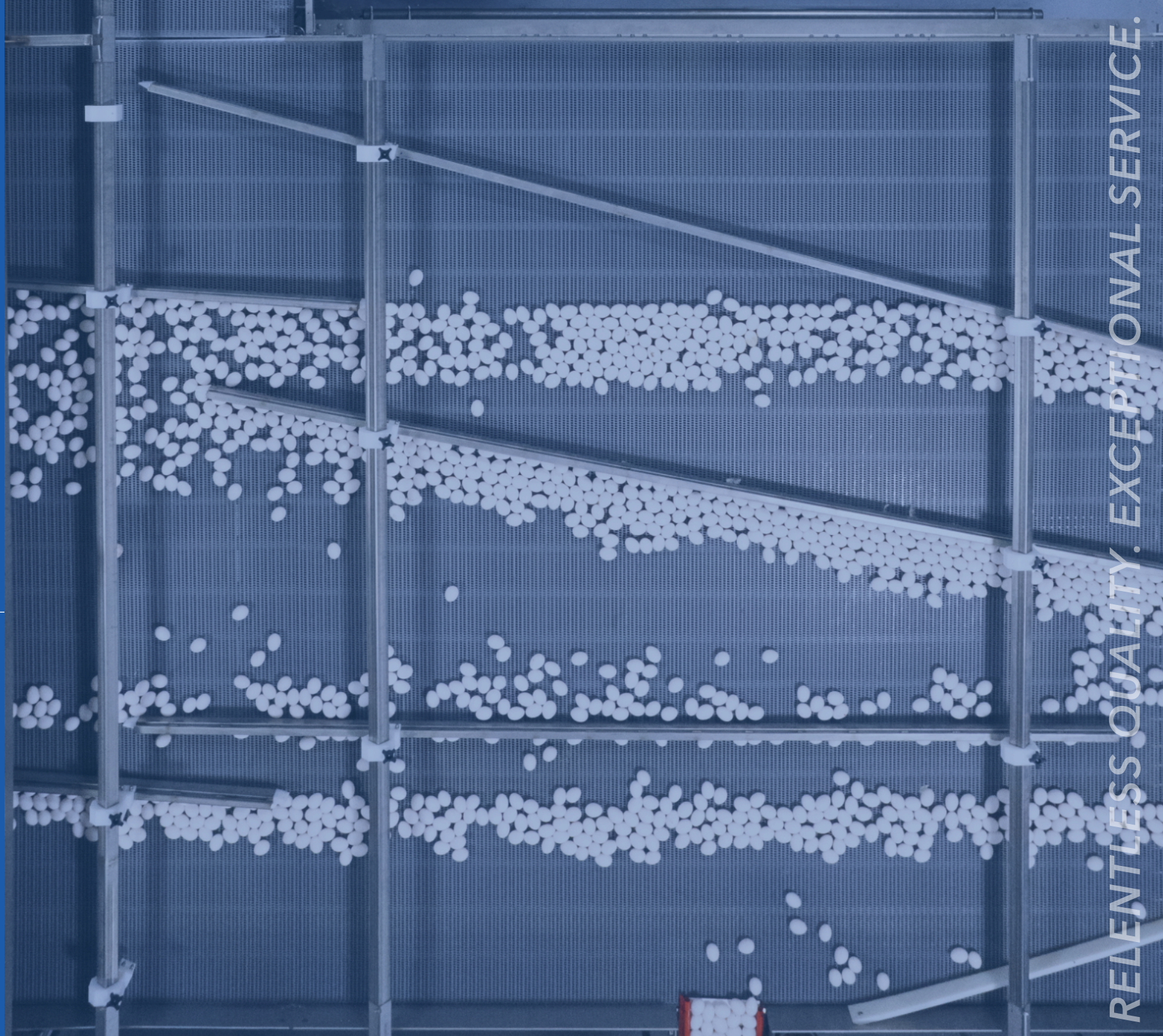

RELENTLESS QUALITY. EXCEPTIONAL SERVICE.

OVERVIEW

Our accumulator table offers increased flexibility in directing eggs into the grading machines from any egg conveying system. All accumulator tables are custom built to order to fit your specific sizing needs.

FEATURES

- Custom lengths and widths available in 6-in increments
- Custom configurations available (L shape or split tables)
- Available in heights from 36 - 54 inches
- Heavy-duty stainless steel construction
- Meets USDA requirements

Fully adjustable transfer plate

Adjustable design offers vertical and horizontal position adjustment as well as angular pitch adjustment to ensure a safe transfer for your eggs.

Rigid design

The side sheets are constructed with heavy-gauge stainless steel and the modular frame is constructed with 2 inch heavy-gauge stainless steel tubing.

Leg supports

The 2 inch heavy-gauge steel legs are firmly locked together offering a structurally rigid frame while the adjustable feet allow for easy leveling of the table.

UHMW Runners

The interlocking belt slides on the UHMW runners allowing a smooth and efficient egg transport.

Diverter arms

Heavy-duty stainless steel diverter arms with quick release and locking tooling facilitate easy adjustment by simply pushing each arm to the desired position to meet your specific needs.

Interlocking belt

The USDA approved belt is made of polypropylene and is self-tensioning. It is available in gray, white and blue.

Bearings

Maintenance-free and easy to replace UHMW bearings.

Access ports

Openings on the side sheets offer easy entry for cleaning.

Washdown Gearbox and Motor

Stober K-Series gearbox and 1/2 HP inverter duty motor offered standard.

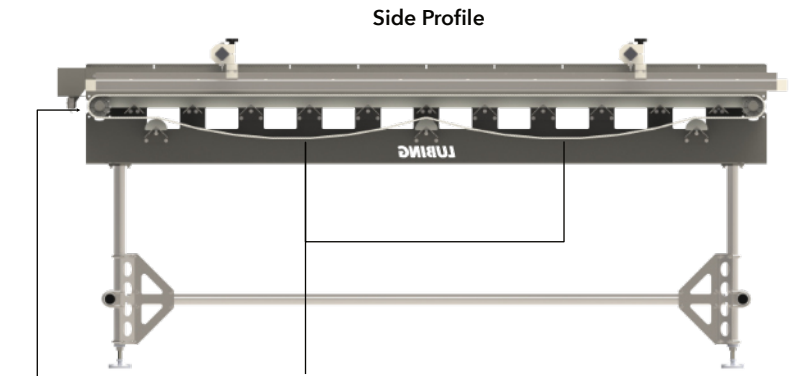
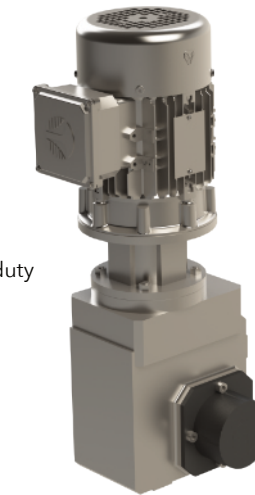

Side Profile

Lower bed design

Improved lower bed design to optimize catenary sag for more consistent tensioning.

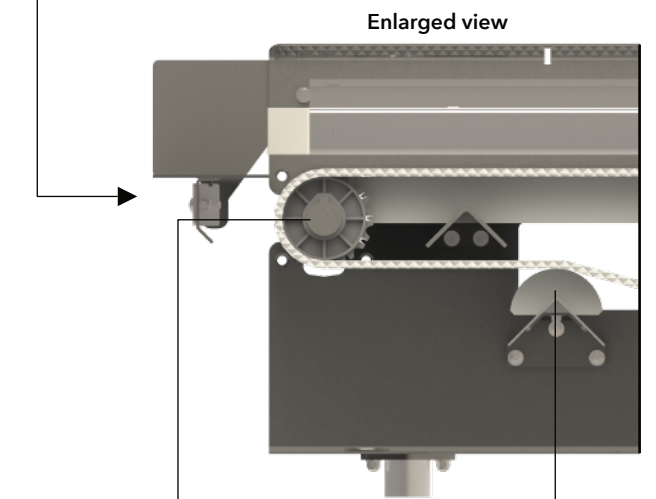

Enlarged view

Solid round idler / drive shaft

Keyed precision machined solid round shaft for added strength and longevity.

Snub roller

Ensures a full 180° belt wrap around sprocket to eliminate risk of belt skipping.



LUBING certified installation services are available upon request.



**"LUBING's accumulator tables are built like a tank,
and I doubt we'll ever need to replace it."**

Greg Davis

Grader facility maintenance supervisor, Rose Acre Farms



Josh Bandy
Conveyor Sales Manager
423-716-0181
jbandy@lubingusa.com

